



MOTOROLA

# Dual EIA-422/423 Transceivers

The MC34050/51 are dual transceivers which comply with EIA Standards EIA-422 (Balanced line) and EIA-423 (Unbalanced line). Each device contains two drivers and two receivers.

The MC34050 has a DRIVER ENABLE (for both drivers) and a RECEIVER ENABLE (for both receivers). Connecting the two ENABLES together provides Driver-to-Receiver switching from a single line.

The MC34051 has a DRIVER ENABLE for each driver. The two receivers are permanently enabled.

The Driver inputs, Receiver outputs, and Enable inputs are 74LS TTL compatible.

- Two Independent Drivers and Receivers Per Package
- 3-State Outputs
- Single 5.0 V Supply
- Internal Hysteresis (50 mV Typical) on Receivers
- Receivers Provide Fail-Safe Function. Output Stays High if Inputs are Open, Shorted (floating), or Terminated (floating)
- Receivers May Be Used in EIA-422 or 423 Systems
- Drivers Meet Full EIA-422 Standards

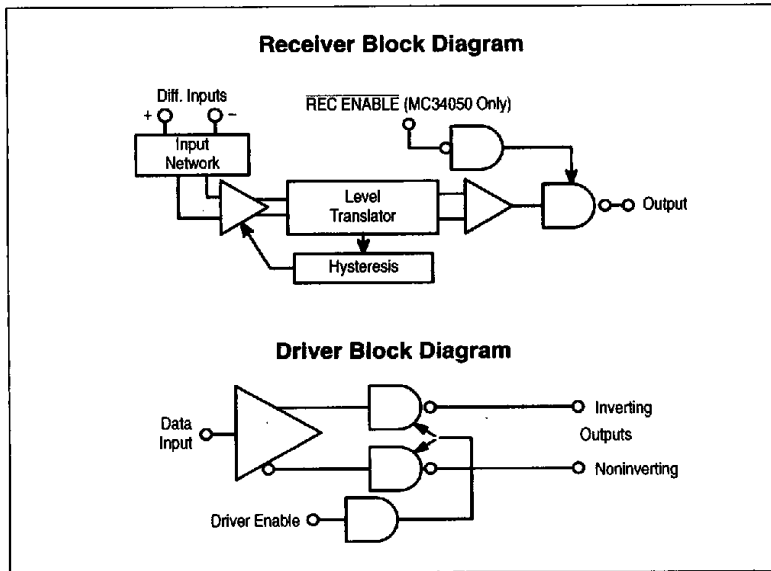

TRUTH TABLE

Driver				Receiver		
Data	EN	Inv. Out	Noninv. Out	Input	EN	Output
L	H	H	L	> + 0.2 V Diff.	L	H
H	H	L	H	< - 0.2 V Diff.	L	L
X	L	Z	Z	X	H	Z

## MC34050 MC34051

### DUAL EIA-422/423 TRANSCIVERS

#### SEMICONDUCTOR TECHNICAL DATA



**D SUFFIX**  
PLASTIC PACKAGE  
CASE 751B  
(SO-16)

**P SUFFIX**  
PLASTIC PACKAGE  
CASE 648



#### PIN CONNECTIONS

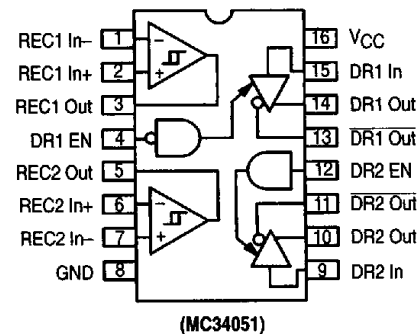
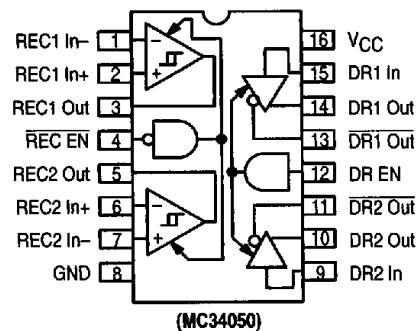

#### ORDERING INFORMATION

Device	Operating Temperature Range	Package
MC34050D	T <sub>A</sub> = 0° to +70°C	SO-16
MC34050P		Plastic DIP
MC34051P		Plastic DIP
MC34051D		SO-16

6367253 0097847 T20

# MC34050 MC34051

## MAXIMUM RATINGS

Rating	Value	Units
Power Supply Voltage ( $V_{CC}$ )	7.0	Vdc
Input Common Mode Voltage (Receivers)	$\pm 25$	Vdc
Input Differential Voltage (Receivers)	$\pm 25$	Vdc
Output Sink Current (Receivers)	50	mA
Enable Input Voltage (Drivers and Receivers)	5.5	Vdc
Input Voltage (Drivers)	5.5	Vdc
Applied Output Voltage (3-State mode) – Receivers	-1.0 to +7.0	Vdc
Applied Output Voltage (3-State mode) – Drivers	-1.0 to +7.0	Vdc
Junction Temperature	-65 to +150	°C
Storage Temperature	-65 to +150	°C

Devices should not be operated at these values.  
The "Recommended Operating Limits" provide for actual device operation.

## RECOMMENDED OPERATING LIMITS

Characteristic	Min	Typ	Max	Unit
Power Supply Voltage	+4.75	+5.0	+5.25	Vdc
Input Common Mode Voltage (Receivers)	-7.0	-	+7.0	Vdc
Input Differential Voltage (Receivers)	-6.0	-	+6.0	Vdc
Enable Input Voltage (Drivers and Receivers)	0	-	+5.25	Vdc
Input Voltage (Drivers)	0	-	+5.25	Vdc
Ambient Temperature Range	0	-	+70	°C

**ELECTRICAL CHARACTERISTICS** (Unless otherwise noted, specifications apply for  $4.75 < V_{CC} < 5.25$  V, and  $0^\circ < T_A < 70^\circ\text{C}$ ).

Characteristic	Symbol	Min	Typ	Max	Unit
----------------	--------	-----	-----	-----	------

### DRIVERS

Input Voltage – Low	$V_{ILD}$	-	-	0.8	Vdc
Input Voltage – High	$V_{IHD}$	2.0	-	-	Vdc
Input Current @ $V_{IL} = 0.4$ V	$I_{ILD}$	-360	-	-	$\mu\text{A}$
Input Current @ $V_{IH} = 2.7$ V $V_{IH} = 5.25$ V	$I_{IHD}$	-	-	+20 +100	$\mu\text{A}$
Input Clamp Voltage ( $I_{IK} = -18$ mA)	$V_{IKD}$	-1.5	-	-	Vdc
Output Voltage – Low ( $I_{OL} = 20$ mA)	$V_{OLD}$	-	-	0.5	Vdc
Output Voltage – High ( $I_{OH} = -20$ mA)	$V_{OHD}$	2.5	-	-	Vdc
Output Offset Voltage Difference (Note 1)	$V_{OSD}$	-0.4	-	+0.4	Vdc
Output Differential Voltage (Note 1)	$V_T$	2.0	-	-	Vdc
Output Differential Voltage Difference (Note 1)	$V_{TD}$	-0.4	-	+0.4	Vdc
Short Circuit Current ( $V_{CC} = 5.25$ V) (From High Output, Note 2)	$I_{OSD}$	-150	-	-30	mA
Output Leakage Current – Hi-Z State ( $V_{out} = 0.5$ V, DR EN = 0.8 V) ( $V_{out} = 2.7$ V, DR EN = 0.8 V)	$I_{OZD}$	-100 -100	-	+100 +100	$\mu\text{A}$
Output Leakage – Power Off ( $V_{out} = -0.25$ V, $V_{CC} = 0$ V) ( $V_{out} = 6.0$ V, $V_{CC} = 0$ V)	$I_{O(off)}$	-100 -	-	- +100	$\mu\text{A}$

**NOTES:** 1. See EIA Standard EIA-422 and Figure 1 for exact test conditions.  
2. Only one output in a package should be shorted at a time, for no longer than 1 second.

6367253 0097848 967

# MC34050 MC34051

**ELECTRICAL CHARACTERISTICS** (Unless otherwise noted, specifications apply for  $4.75 < V_{CC} < 5.25$  V, and  $0^\circ < T_A < 70^\circ$ C).

Characteristic	Symbol	Min	Typ	Max	Unit
<b>RECEIVERS</b>					
Differential Input Threshold Voltage (Note 3) ( $-7.0$ V $< V_{ICM} < 7.0$ , $V_{out} \geq 2.7$ V) ( $-7.0$ V $< V_{ICM} < 7.0$ , $V_{out} \leq 0.45$ V)	$V_{THR}$	-	-	+0.2	Vdc
		-0.2	-	-	
Input Bias Current ( $0 \leq V_{CC} \leq 5.25$ V, $V_{in} = 15$ V) ( $0 \leq V_{CC} \leq 5.25$ V, $V_{in} = -15$ V)	$I_{IBR}$	-	-	+2.3	mA
		-2.8	-	-	
Input Balance and Output Level ( $-7.0 \leq V_{ICM} \leq 7.0$ V) ( $V_{ID} = 0.4$ V, $I_O = -400$ $\mu$ A) ( $V_{ID} = -0.4$ V, $I_O = 8.0$ mA)	$V_{OHR}$ $V_{OLR}$	2.7	-	-	Vdc
		-	-	0.45	
Output Leakage Current – 3-State (Pin 4 = 2.0 V, MC34050 only) ( $V_{ID} = 3.0$ V, $V_O = 0.4$ V) ( $V_{ID} = -3.0$ V, $V_O = 2.4$ V)	$I_{OZR}$	-100	-	+100	$\mu$ A
		-100	-	+100	
Output Short Circuit Current (Note 2, $V_{CC} = 5.25$ V) ( $V_{ID} = 3.0$ V, MC34050 Pin 4 = 0.4 V, $V_O = 0$ V)	$I_{OSR}$	-85	-	-15	mA

## ENABLES

Input Voltage – Low	$V_{ILE}$	-	-	0.8	Vdc
Input Voltage – High	$V_{IHE}$	2.0	-	-	Vdc
Input Current @ $V_{IL} = 0.4$ V (Receiver EN) (Driver EN)	$I_{ILER}$ $I_{ILED}$	-100	-	-	$\mu$ A
		-360	-	-	
Input Current @ $V_{IH} = 2.7$ V $V_{IH} = 5.25$ V	$I_{IHE}$	-	-	+20	$\mu$ A
		-	-	+100	
Input Clamp Voltage ( $I_{IK} = -18$ mA)	$V_{IKE}$	-1.5	-	-	Vdc

## POWER SUPPLY

Power Supply Current @ $V_{CC} = 5.25$ V	$I_{CC}$	-	55	80	mA
--	----------	---	----	----	----

**NOTES:** 2. Only one output in a package should be shorted at a time, for no longer than 1 second.  
3. Differential input threshold voltage and guaranteed output levels are done simultaneously for worst case.

## DRIVER SWITCHING CHARACTERISTICS ( $V_{CC} = 5.0$ V, $T_A = 25^\circ$ C, see Figure 2).

Characteristic	Symbol	Min	Typ	Max	Unit
Propagation Delay					ns
Data Input to Output High-to-Low	$t_{PHLD}$	-	-	20	
Data Input to Output Low-to-High	$t_{PLHD}$	-	-	20	
Output Skew ( $ t_{PHL} - t_{PLH} $ each driver)	$t_{SKD}$	-	-	8	
Enable Input to Output					
$C_L = 10$ pF, $R_L = 75$ $\Omega$ to Gnd	$t_{PHZD}$	-	-	30	
$C_L = 10$ pF, $R_L = 180$ $\Omega$ to $V_{CC}$	$t_{PLZD}$	-	-	35	
$C_L = 30$ pF, $R_L = 75$ $\Omega$ to Gnd	$t_{PZHD}$	-	-	40	
$C_L = 30$ pF, $R_L = 180$ $\Omega$ to $V_{CC}$	$t_{PZLD}$	-	-	45	
Maximum Data Input Transition Time (10% to 90%)	$t_{TRD}$	-	50	-	ns

## RECEIVER SWITCHING CHARACTERISTICS ( $V_{CC} = 5.0$ V, $T_A = 25^\circ$ C, see Figure 3).

Characteristic	Symbol	Min	Typ	Max	Unit
Propagation Delay					ns
Differential Input to Output – High-to-Low	$t_{PHLR}$	-	-	30	
Differential Input to Output – Low-to-High	$t_{PLHR}$	-	-	30	
Enable Input – Output Low to 3-State	$t_{PLZR}$	-	-	35	
Enable Input – Output High to 3-State	$t_{PHZR}$	-	-	35	
Enable Input – Output 3-State to High	$t_{PZHR}$	-	-	30	
Enable Input – Output 3-State to Low	$t_{PZLR}$	-	-	30	

} MC34050 Only

6367253 0097849 8T3