



MOTOROLA

Order this document by MC34065-H/D

# MC34065-H, L MC33065-H, L

## High Performance Dual Channel Current Mode Controllers

The MC34065-H,L series are high performance, fixed frequency, dual current mode controllers. They are specifically designed for off-line and dc-to-dc converter applications offering the designer a cost effective solution with minimal external components. These integrated circuits feature a unique oscillator for precise duty cycle limit and frequency control, a temperature compensated reference, two high gain error amplifiers, two current sensing comparators, Drive Output 2 Enable pin, and two high current totem pole outputs ideally suited for driving power MOSFETs.

Also included are protective features consisting of input and reference undervoltage lockouts each with hysteresis, cycle-by-cycle current limiting, and a latch for single pulse metering of each output. These devices are available in dual-in-line and surface mount packages.

The MC34065-H has UVLO thresholds of 14 V (on) and 10 V (off), ideally suited for off-line converters. The MC34065-L is tailored for lower voltage applications having UVLO thresholds of 8.4 V (on) and 7.8 V (off).

- Unique Oscillator for Precise Duty Cycle Limit and Frequency Control
- Current Mode Operation to 500 kHz
- Automatic Feed Forward Compensation
- Separate Latching PWMs for Cycle-By-Cycle Current Limiting
- Internally Trimmed Reference with Undervoltage Lockout
- Drive Output 2 Enable Pin
- Two High Current Totem Pole Outputs
- Input Undervoltage Lockout with Hysteresis
- Low Startup and Operating Current

### HIGH PERFORMANCE DUAL CHANNEL CURRENT MODE CONTROLLERS

#### SEMICONDUCTOR TECHNICAL DATA

**P SUFFIX**  
PLASTIC PACKAGE  
CASE 648

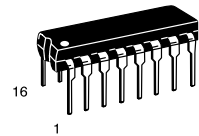

**DW SUFFIX**  
PLASTIC PACKAGE  
CASE 751G  
(SO-16L)

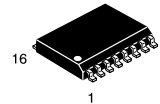

#### PIN CONNECTIONS

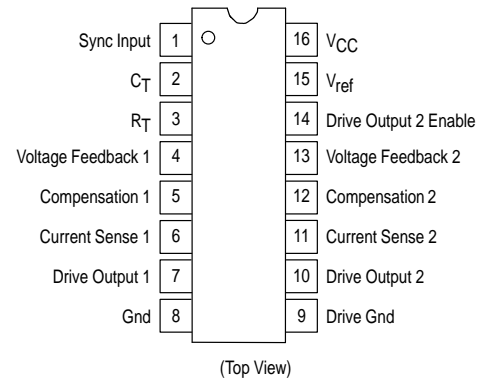

#### Representative Block Diagram

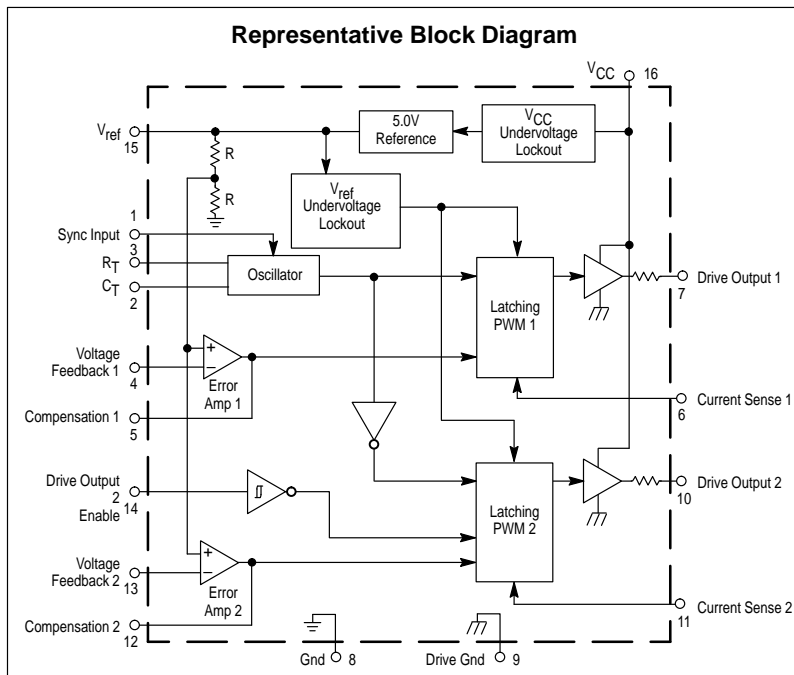

#### ORDERING INFORMATION

Device	Operating Temperature Range	Package
MC34065DW-H	$T_A = 0^\circ \text{ to } +70^\circ\text{C}$	SO-16L
MC34065DW-L		Plastic DIP
MC34065P-H		
MC34065P-L		
MC33065DW-H	$T_A = -40^\circ \text{ to } +85^\circ\text{C}$	SO-16L
MC33065DW-L		Plastic DIP
MC33065P-H		
MC33065P-L		

# MC34065–H, L MC33065–H, L

## MAXIMUM RATINGS

Rating	Symbol	Value	Unit
Power Supply Voltage	$V_{CC}$	20	V
Output Current, Source or Sink (Note 1)	$I_O$	400	mA
Output Energy (Capacitive Load per Cycle)	W	5.0	$\mu$ J
Current Sense, Enable, and Voltage Feedback Inputs	$V_{in}$	– 0.3 to +5.5	V
Sync Input High State (Voltage)	$V_{IH}$	+5.5	V
Low State (Reverse Current)	$I_{IL}$	– 5.0	mA
Error Amp Output Sink Current	$I_O$	10	mA
Power Dissipation and Thermal Characteristics DW Suffix, Plastic Package Case 751G Maximum Power Dissipation @ $T_A = 25^\circ\text{C}$ Thermal Resistance, Junction-to-Air	$P_D$ $R_{\theta JA}$	862 145	mW $^\circ\text{C/W}$
P Suffix, Plastic Package Case 648 Maximum Power Dissipation @ $T_A = 25^\circ\text{C}$ Thermal Resistance, Junction-to-Air	$P_D$ $R_{\theta JA}$	1.25 100	mW $^\circ\text{C/W}$
Operating Junction Temperature	$T_J$	+150	$^\circ\text{C}$
Operating Ambient Temperature (Note 3) MC34065 MC33065	$T_A$	0 to +70 – 40 to +85	$^\circ\text{C}$
Storage Temperature Range	$T_{stg}$	– 65 to +150	$^\circ\text{C}$

**ELECTRICAL CHARACTERISTICS** ( $V_{CC} = 15\text{ V}$  [Note 2],  $R_T = 8.2\text{ k}\Omega$ ,  $C_T = 3.3\text{ nF}$ , for typical values  $T_A = 25^\circ\text{C}$ , for min/max values  $T_A$  is the operating ambient temperature range that applies to [Note 3].)

Characteristics	Symbol	Min	Typ	Max	Unit
-----------------	--------	-----	-----	-----	------

## REFERENCE SECTION

Reference Output Voltage ( $I_O = 1.0\text{ mA}$ , $T_J = 25^\circ\text{C}$ )	$V_{ref}$	4.85	5.0	5.13	V
Line Regulation ( $V_{CC} = 11\text{ V to } 20\text{ V}$ )	Reg <sub>line</sub>	–	2.0	20	mV
Load Regulation ( $I_O = 1.0\text{ mA to } 10\text{ mA}$ , $V_{CC} = 20\text{ V}$ )	Reg <sub>load</sub>	–	3.0	25	mV
Total Output Variation over Line, Load, and Temperature	$V_{ref}$	4.8	–	5.15	V
Output Short Circuit Current	$I_{SC}$	30	100	–	mA

## OSCILLATOR AND PWM SECTIONS

Total Frequency Variation over Line and Temperature $V_{CC} = 11\text{ V to } 20\text{ V}$ , $T_A = T_{low}\text{ to } T_{high}$ MC34065 MC33065	$f_{osc}$	46.5 45	49 49	51.5 53	kHz
Frequency Change with Voltage ( $V_{CC} = 11\text{ V to } 20\text{ V}$ )	$\Delta f_{osc}/\Delta V$	–	0.2	1.0	%
Duty Cycle at each Output Maximum Minimum	$DC_{max}$ $DC_{min}$	46 –	49.5 –	52 0	%
Sync Input Current High State ( $V_{in} = 2.4\text{ V}$ ) Low State ( $V_{in} = 0.8\text{ V}$ )	$I_{IH}$ $I_{IL}$	– –	170 80	250 160	$\mu$ A

## ERROR AMPLIFIERS

Voltage Feedback Input ( $V_O = 2.5\text{ V}$ )	$V_{FB}$	2.45	2.5	2.55	V
Input Bias Current ( $V_{FB} = 5.0\text{ V}$ )	$I_{IB}$	–	– 0.1	– 1.0	$\mu$ A
Open Loop Voltage Gain ( $V_O = 2.0\text{ V to } 4.0\text{ V}$ )	$A_{VOL}$	65	100	–	dB
Unity Gain Bandwidth ( $T_J = 25^\circ\text{C}$ )	BW	0.7	1.0	–	MHz
Power Supply Rejection Ratio ( $V_{CC} = 11\text{ V to } 20\text{ V}$ )	PSRR	60	90	–	dB
Output Current Source ( $V_O = 3.0\text{ V}$ , $V_{FB} = 2.3\text{ V}$ ) Sink ( $V_O = 1.2\text{ V}$ , $V_{FB} = 2.7\text{ V}$ )	$I_{source}$ $I_{sink}$	0.45 2.0	1.0 12	– –	mA
Output Voltage Swing High State ( $R_L = 15\text{ k to ground}$ , $V_{FB} = 2.3\text{ V}$ ) Low State ( $R_L = 15\text{ k to } V_{ref}$ , $V_{FB} = 2.7\text{ V}$ )	$V_{OH}$ $V_{OL}$	5.0 –	6.2 0.8	– 1.1	V

# MC34065–H, L MC33065–H, L

**ELECTRICAL CHARACTERISTICS** ( $V_{CC} = 15\text{ V}$  [Note 2],  $R_T = 8.2\text{ k}\Omega$ ,  $C_T = 3.3\text{ nF}$ , for typical values  $T_A = 25^\circ\text{C}$ , for min/max values  $T_A$  is the operating ambient temperature range that applies to [Note 3].)

Characteristics	Symbol	Min	Typ	Max	Unit
-----------------	--------	-----	-----	-----	------

## CURRENT SENSE SECTION

Current Sense Input Voltage Gain (Notes 4 and 5)	$A_V$	2.75	3.0	3.25	V/V
Maximum Current Sense Input Threshold (Note 4)	$V_{th}$	0.9	1.0	1.1	V
Input Bias Current	$I_{IB}$	–	–2.0	–10	$\mu\text{A}$
Propagation Delay (Current Sense Input to Output)	$t_{PLN}(\text{In/Out})$	–	150	300	ns

## DRIVE OUTPUT 2 ENABLE PIN

Enable Pin Voltage – High State (Output 2 Enabled) – Low State (Output 2 Disabled)	$V_{IH}$ $V_{IL}$	3.5 0	– –	$V_{ref}$ 1.5	V
Low State Input Current ( $V_{IL} = 0\text{ V}$ )	$I_{IB}$	100	250	400	$\mu\text{A}$

## DRIVE OUTPUTS

Output Voltage – Low State ( $I_{sink} = 20\text{ mA}$ ) ( $I_{sink} = 200\text{ mA}$ ) – High State ( $I_{source} = 20\text{ mA}$ ) ( $I_{source} = 200\text{ mA}$ )	$V_{OL}$ $V_{OH}$	– 1.6 12.8 10	0.3 2.4 13.3 11.2	0.5 3.0 – 12.3	V
Output Voltage with UVLO Activated ( $V_{CC} = 6.0\text{ V}$ , $I_{Sink} = 1.0\text{ mA}$ )	$V_{OL}(\text{UVLO})$	–	0.1	1.1	V
Output Voltage Rise Time ( $C_L = 1.0\text{ nF}$ )	$t_r$	–	50	150	ns
Output Voltage Fall Time ( $C_L = 1.0\text{ nF}$ )	$t_f$	–	50	150	ns

## UNDERVOLTAGE LOCKOUT SECTION

Startup Threshold ( $V_{CC}$ Increasing) –L Suffix –H Suffix	$V_{th}$	7.8 13	8.4 14	9.0 15	V
Minimum Operating Voltage After Turn–On ( $V_{CC}$ Decreasing) –L Suffix –H Suffix	$V_{CC}(\text{min})$	7.2 9.0	7.8 10	8.4 11	V

## TOTAL DEVICE

Power Supply Current Startup –L Suffix ( $V_{CC} = 6.0\text{ V}$ ) –H Suffix ( $V_{CC} = 12\text{ V}$ ) Operating (Note 2)	$I_{CC}$	– – –	0.4 0.6 20	0.8 1.0 25	mA
--	----------	-------------	------------------	------------------	----

- NOTES:** 1. Maximum package power dissipation limits must be observed.  
2. Adjust  $V_{CC}$  above the startup threshold before setting to 15 V.  
3. Low duty cycle pulse techniques are used during test to maintain junction temperature as close to ambient as possible:  
 $T_{low} = 0^\circ\text{C}$  for the MC34065  
 $T_{low} = -40^\circ\text{C}$  for the MC33065  
 $T_{high} = +70^\circ\text{C}$  for MC34065  
 $T_{high} = +85^\circ\text{C}$  for MC33065

4. This parameter is measured at the latch trip point with  $V_{FB} = 0\text{ V}$   
5. Comparator gain is defined as  $A_V = \frac{\Delta V_{\text{Compensation}}}{\Delta V_{\text{Current Sense}}}$

**Figure 1. Timing Resistor versus Oscillator Frequency**

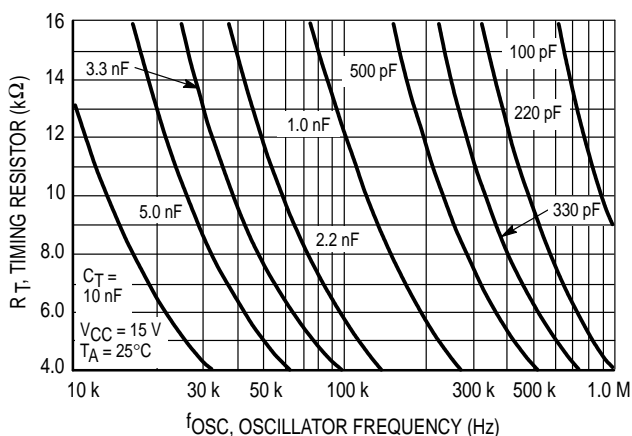

**Figure 2. Maximum Output Duty Cycle versus Oscillator Frequency**

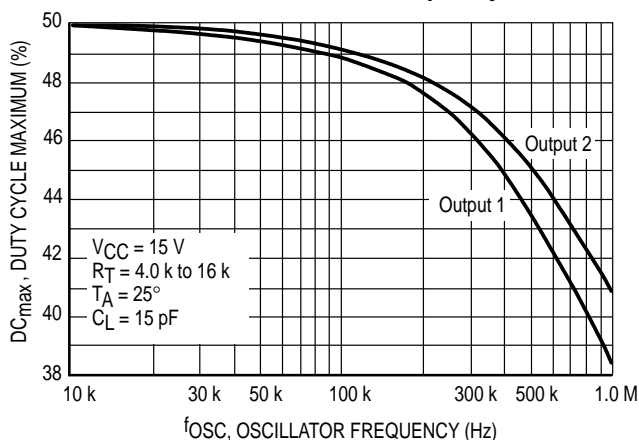

Figure 3. Error Amp Small-Signal Transient Response

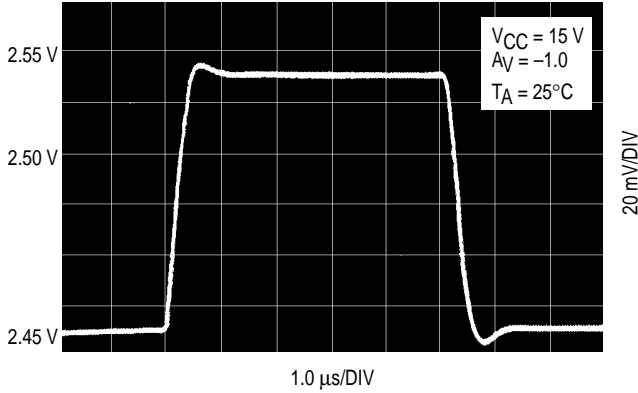

Figure 4. Error Amp Large-Signal Transient Response

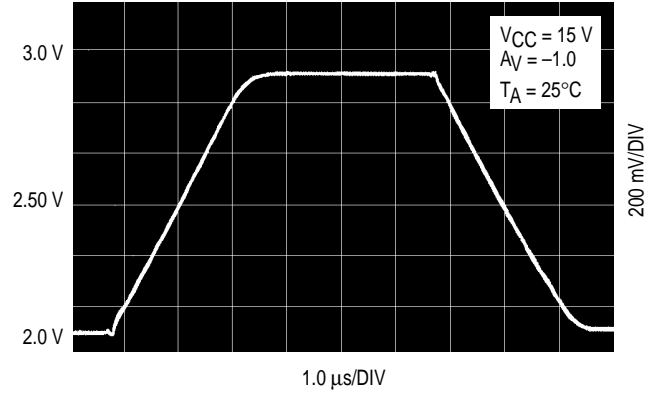

Figure 5. Error Amp Open Loop Gain and Phase versus Frequency

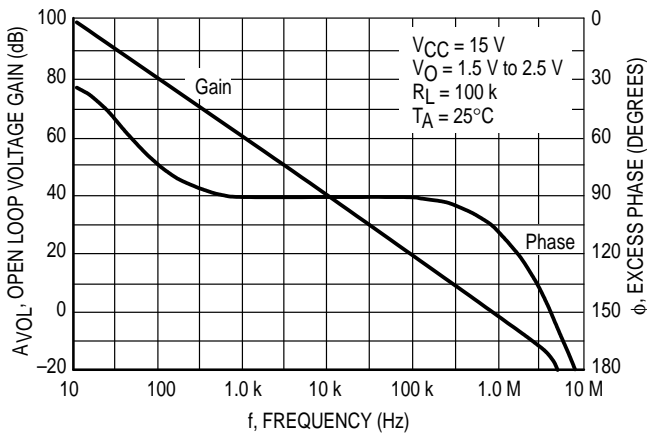

Figure 6. Current Sense Input Threshold versus Error Amp Output Voltage

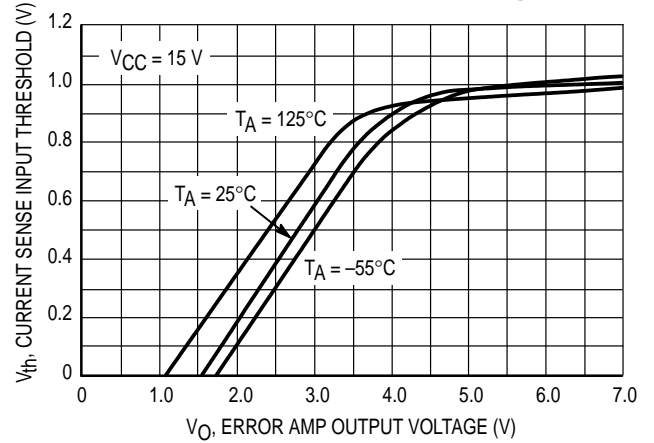

Figure 7. Reference Voltage Change versus Source Current

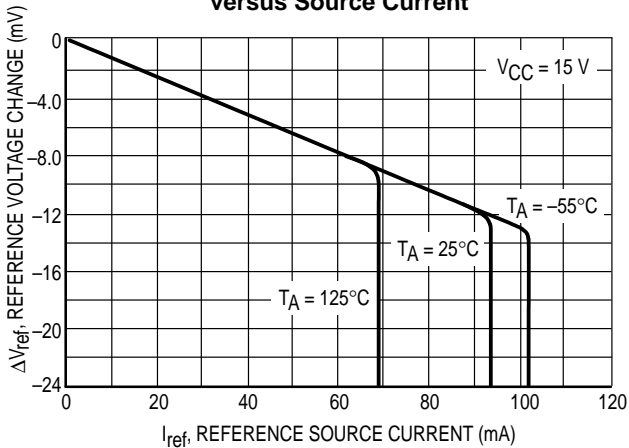

Figure 8. Reference Short Circuit Current versus Temperature

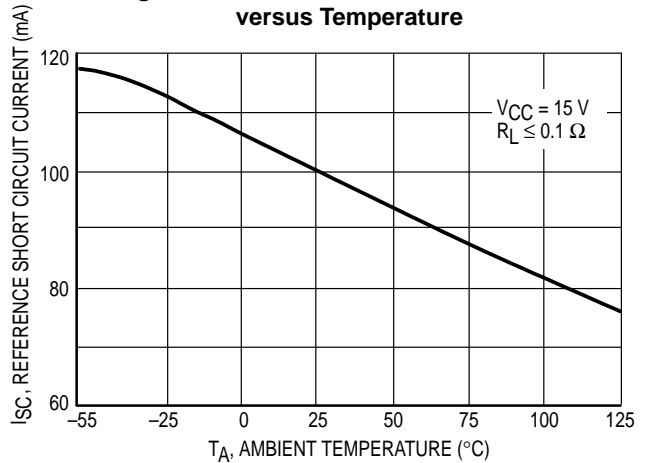

Figure 9. Reference Load Regulation

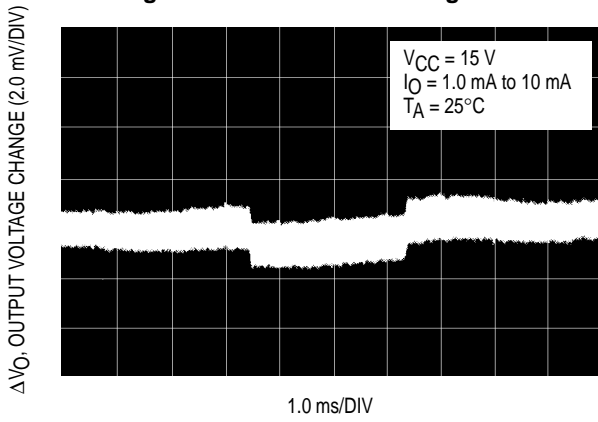

Figure 10. Reference Line Regulation

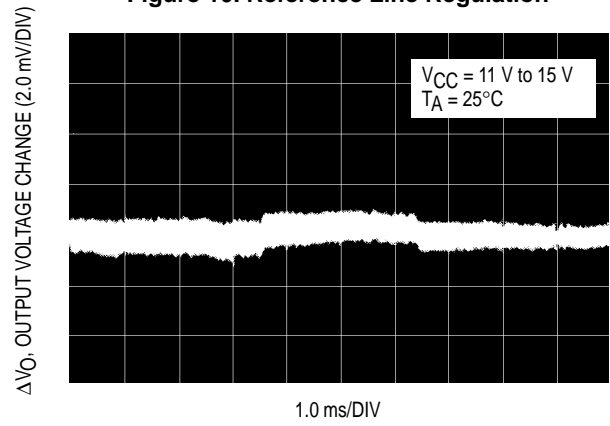

Figure 11. Output Saturation Voltage versus Load Current

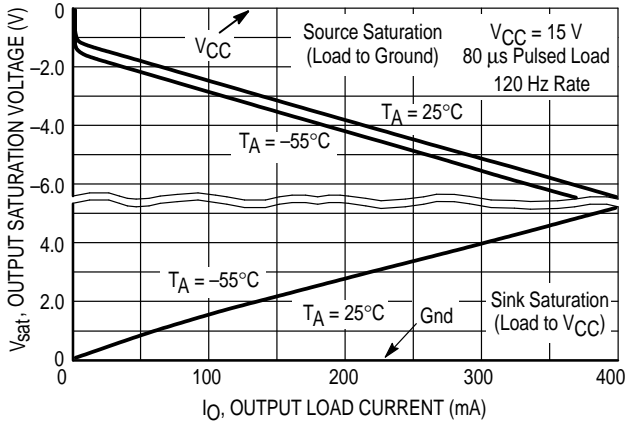

Figure 12. Output Waveform

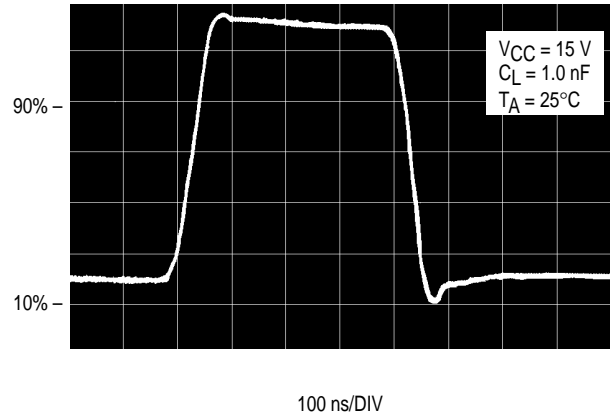

Figure 13. Output Cross Conduction Current

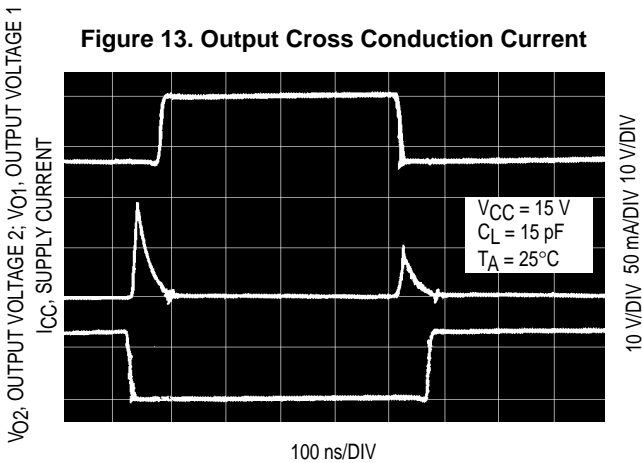
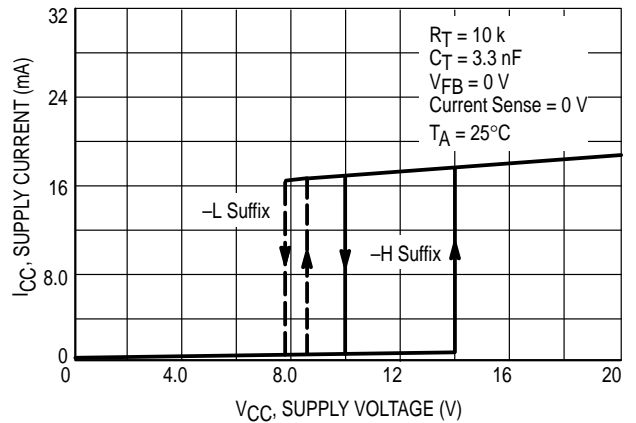

Figure 14. Supply Current versus Supply Voltage



## MC34065–H, L MC33065–H, L

### OPERATING DESCRIPTION

The MC34065–H,L series are high performance, fixed frequency, dual channel current mode controllers specifically designed for Off–Line and dc–to–dc converter applications. These devices offer the designer a cost effective solution with minimal external components where independent regulation of two power converters is required. The Representative Block Diagram is shown in Figure 15. Each channel contains a high gain error amplifier, current sensing comparator, pulse width modulator latch, and totem pole output driver. The oscillator, reference regulator, and undervoltage lock–out circuits are common to both channels.

#### Oscillator

The unique oscillator configuration employed features precise frequency and duty cycle control. The frequency is programmed by the values selected for the timing components  $R_T$  and  $C_T$ . Capacitor  $C_T$  is charged and discharged by an equal magnitude internal current source and sink, generating a symmetrical 50 percent duty cycle waveform at Pin 2. The oscillator peak and valley thresholds are 3.5 V and 1.6 V respectively. The source/sink current magnitude is controlled by resistor  $R_T$ . For proper operation over temperature it must be in the range of 4.0 k $\Omega$  to 16 k $\Omega$  as shown in Figure 1.

As  $C_T$  charges and discharges, an internal blanking pulse is generated that alternately drives the center inputs of the upper and lower NOR gates high. This, in conjunction with a precise amount of delay time introduced into each channel, produces well defined non–overlapping output duty cycles. Output 2 is enabled while  $C_T$  is charging, and Output 1 is enabled during the discharge. Figure 2 shows the Maximum Output Duty Cycle versus Oscillator Frequency. Note that even at 500 kHz, each output is capable of approximately 44% on–time, making this controller suitable for high frequency power conversion applications.

In many noise sensitive applications it may be desirable to frequency–lock the converter to an external system clock. This can be accomplished by applying a clock signal as shown in Figure 17. For reliable locking, the free–running oscillator frequency should be set about 10% less than the clock frequency. Referring to the timing diagram shown in Figure 16, the rising edge of the clock signal applied to the Sync input, terminates charging of  $C_T$  and Drive Output 2 conduction. By tailoring the clock waveform symmetry, accurate duty cycle clamping of either output can be achieved. A circuit method for this, and multi–unit synchronization, is shown in Figure 18.

#### Error Amplifier

Each channel contains a fully–compensated Error Amplifier with access to the inverting input and output. The amplifier features a typical dc voltage gain of 100 dB, and a unity gain bandwidth of 1.0 MHz with 71° of phase margin (Figure 5). The noninverting input is internally biased at 2.5 V and is not pinned out. The converter output voltage is typically divided down and monitored by the inverting input through a resistor divider. The maximum input bias current is –1.0  $\mu$ A which will cause an output voltage error that is equal to the product of the input bias current and the equivalent input divider source resistance.

The Error Amp output (Pin 5, 12) is provided for external loop compensation. The output voltage is offset by two diode

drops ( $\approx$ 1.4 V) and divided by three before it connects to the inverting input of the Current Sense Comparator. This guarantees that no pulses appear at the Drive Output (Pin 7, 10) when the error amplifier output is at its lowest state ( $V_{OL}$ ). This occurs when the power supply is operating and the load is removed, or at the beginning of a soft–start interval (Figures 20, 21).

The minimum allowable Error Amp feedback resistance is limited by the amplifier's source current (0.5 mA) and the output voltage ( $V_{OH}$ ) required to reach the comparator's 1.0 V clamp level with the inverting input at ground. This condition happens during initial system startup or when the sensed output is shorted:

$$R_{f(\min)} \approx \frac{3.0 (1.0 \text{ V}) + 1.4 \text{ V}}{0.5 \text{ mA}} = 8800 \Omega$$

#### Current Sense Comparator and PWM Latch

The MC34065 operates as a current mode controller, whereby output switch conduction is initiated by the oscillator and terminated when the peak inductor current reaches the threshold level established by the Error Amplifier output. Thus the error signal controls the peak inductor current on a cycle–by–cycle basis. The Current Sense Comparator–PWM Latch configuration used ensures that only a single pulse appears at the Drive Output during any given oscillator cycle. The inductor current is converted to a voltage by inserting a ground–referenced sense resistor  $R_S$  in series with the source of output switch Q1. This voltage is monitored by the Current Sense Input (Pin 6, 11) and compared to a level derived from the Error Amp output. The peak inductor current under normal operating conditions is controlled by the voltage at Pin 5, 12 where:

$$I_{pk} = \frac{V(\text{Pin 5, 12}) - 1.4 \text{ V}}{3 R_S}$$

Abnormal operating conditions occur when the power supply output is overloaded or if output voltage sensing is lost. Under these conditions, the Current Sense Comparator threshold will be internally clamped to 1.0 V. Therefore the maximum peak switch current is:

$$I_{pk(\max)} = \frac{1.0 \text{ V}}{R_S}$$

When designing a high power switching regulator it may be desirable to reduce the internal clamp voltage in order to keep the power dissipation of  $R_S$  to a reasonable level. A simple method to adjust this voltage is shown in Figure 19. The two external diodes are used to compensate the internal diodes, yielding a constant clamp voltage over temperature. Erratic operation due to noise pickup can result if there is an excessive reduction of the  $I_{pk(\max)}$  clamp voltage.

A narrow spike on the leading edge of the current waveform can usually be observed and may cause the power supply to exhibit an instability when the output is lightly loaded. This spike is due to the power transformer interwinding capacitance and output rectifier recovery time. The addition of an RC filter on the Current Sense input with a time constant that approximates the spike duration will usually eliminate the instability, refer to Figure 24.

**Undervoltage Lockout**

Two Undervoltage Lockout comparators have been incorporated to guarantee that the IC is fully functional before the output stages are enabled. The positive power supply terminal ( $V_{CC}$ ) and the reference output ( $V_{ref}$ ) are each monitored by separate comparators. Each has built-in hysteresis to prevent erratic output behavior as their respective thresholds are crossed. The  $V_{CC}$  comparator upper and lower thresholds are 14 V/10 V for –H suffix, and 8.4 V/7.6 V for –L suffix. The  $V_{ref}$  comparator upper and lower thresholds are 3.6 V/3.4 V respectively. The large hysteresis and low startup current of the –H suffix version makes it ideally suited in off-line converter applications where efficient bootstrap startup techniques are required (Figure 28). The –L suffix version is intended for lower voltage dc-to-dc converter applications. The minimum operating voltage for the –H suffix is 11 V and 8.2 V for the –L suffix.

**Drive Outputs and Drive Ground**

Each section contains a single totem-pole output stage that is specifically designed for direct drive of power MOSFETs. The Drive Outputs are capable of up to  $\pm 400$  mA peak current with a typical rise and fall time of 50 ns with a 1.0 nF load. Additional internal circuitry has been added to keep the outputs in a sinking mode whenever an Undervoltage Lockout is active. This characteristic eliminates the need for an external pull-down resistor. The totem-pole output has been optimized to minimize cross-conduction current in high speed operation. The addition of two 10  $\Omega$  resistors, one in series with the source output transistor and one in series with the sink output transistor, reduces the cross-conduction current to minimal levels, as shown in Figure 13.

Although the Drive Outputs were optimized for MOSFETs, they can easily supply the negative base current required by bipolar NPN transistors for enhanced turn-off (Figure 25).

**Figure 15. Representative Block Diagram**

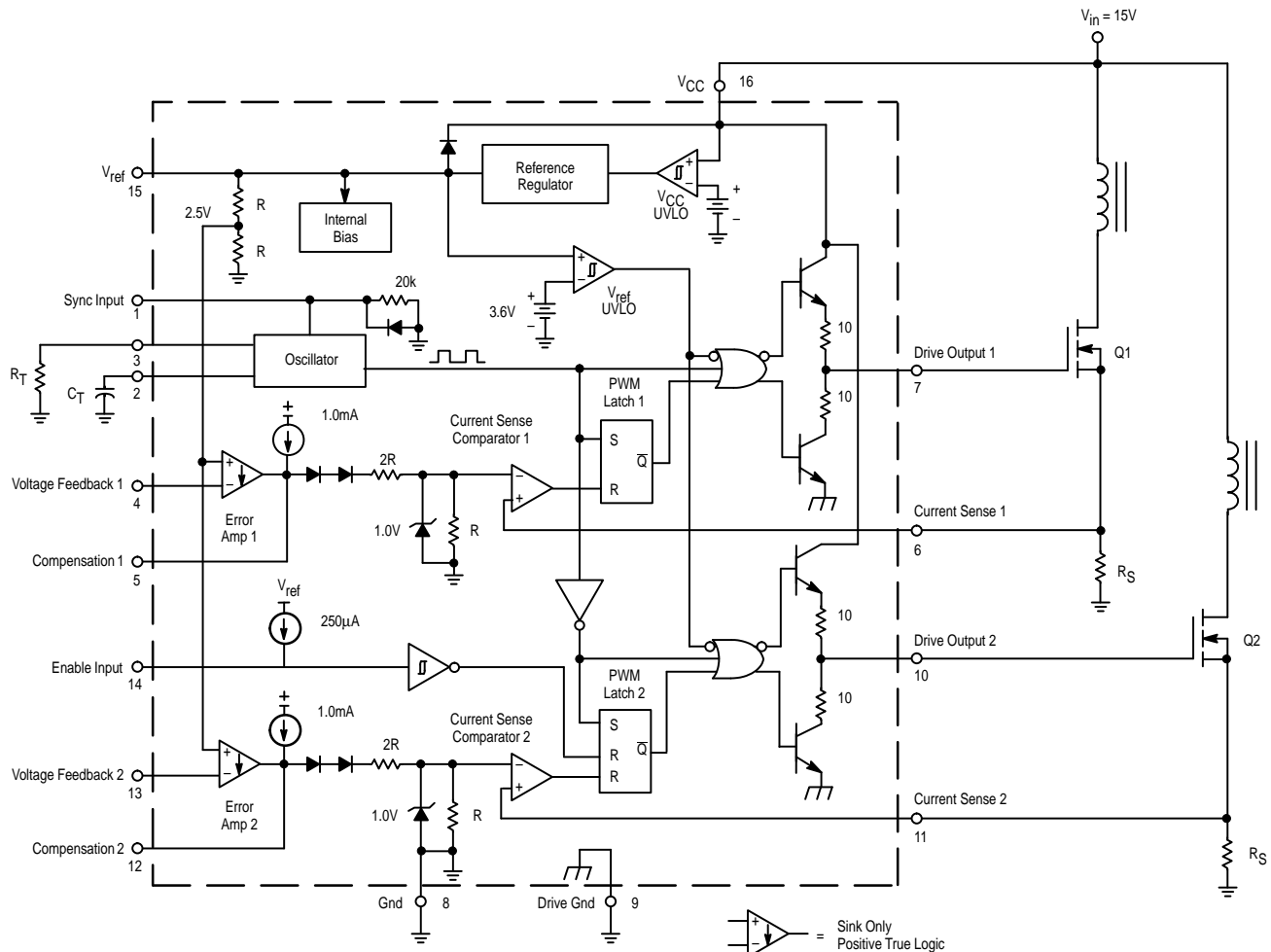
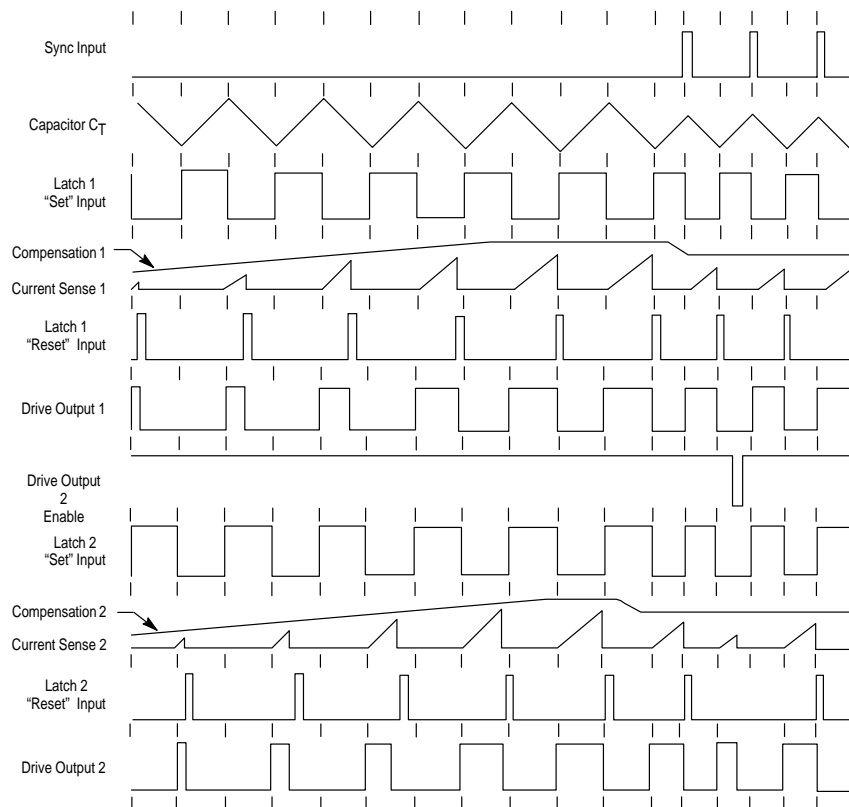

Figure 16. Timing Diagram



The outputs do not contain internal current limiting, therefore an external series resistor may be required to prevent the peak output current from exceeding the  $\pm 400$  mA maximum rating. The sink saturation ( $V_{OL}$ ) is less than 0.75 V at 50 mA.

A separate Drive Ground pin is provided and, with proper implementation, will significantly reduce the level of switching transient noise imposed on the control circuitry. This becomes particularly useful when reducing the  $I_{pk(max)}$  clamp level. Figure 23 shows the proper ground connections required for current sensing power MOSFET applications.

#### Drive Output 2 Enable Pin

This input is used to enable Drive Output 2. Drive Output 1 can be used to control circuitry that must run continuously such as volatile memory and the system clock, or a remote controlled receiver, while Drive Output 2 controls the high power circuitry that is occasionally turned off.

#### Reference

The 5.0 V bandgap reference is trimmed to  $\pm 2.0\%$  tolerance at  $T_J = 25^\circ\text{C}$ . The reference has short circuit protection and is capable of providing in excess of 30 mA for powering any additional control system circuitry.

#### Design Considerations

**Do not attempt to construct the converter on wire-wrap or plug-in prototype boards.** High frequency circuit layout techniques are imperative to prevent pulse-width jitter. This is usually caused by excessive noise pick-up imposed on the Current Sense or Voltage Feedback inputs. Noise immunity can be improved by lowering circuit impedances at these points. The printed circuit layout should contain a ground plane with low current signal and high current switch and output grounds returning on separate paths back to the input filter capacitor. Ceramic bypass capacitors (0.1  $\mu\text{F}$ ) connected directly to  $V_{CC}$  and  $V_{ref}$  may be required depending upon circuit layout. This provides a low impedance path for filtering the high frequency noise. All high current loops should be kept as short as possible using heavy copper runs to minimize radiated EMI. The Error Amp compensation circuitry and the converter output voltage-divider should be located close to the IC and as far as possible from the power switch and other noise generating components.

# MC34065–H, L MC33065–H, L

**Figure 17. External Clock Synchronization**

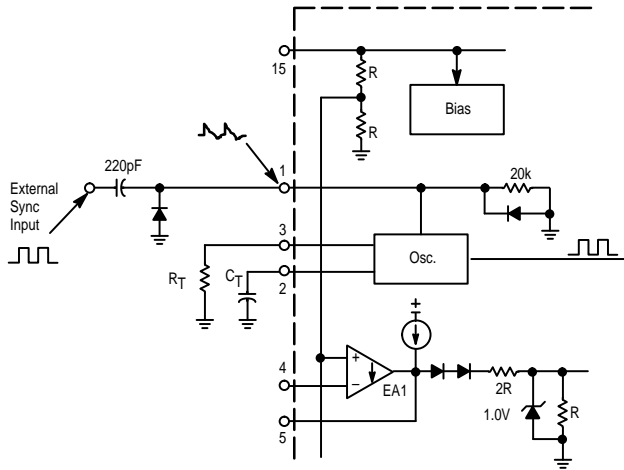

The external diode clamp is required if the negative Sync current is greater than  $-5.0$  mA.

**Figure 18. External Duty Cycle Clamp and Multi-Unit Synchronization**

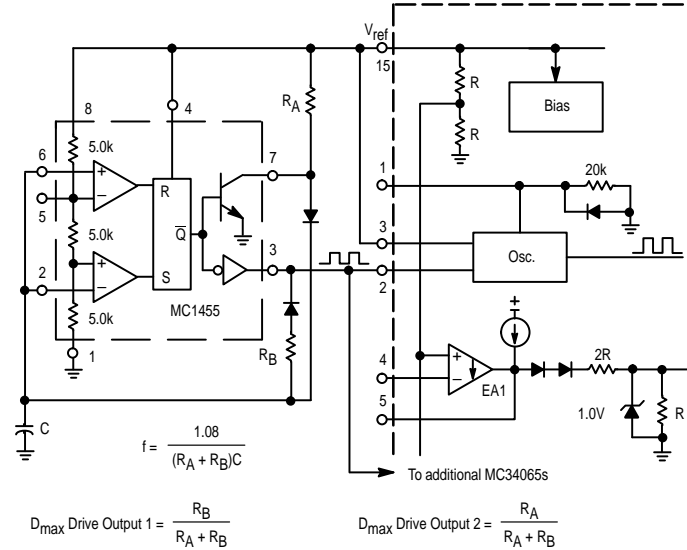

$$D_{\max} \text{ Drive Output 1} = \frac{R_B}{R_A + R_B}$$

$$D_{\max} \text{ Drive Output 2} = \frac{R_A}{R_A + R_B}$$

## PIN FUNCTION DESCRIPTION

Pin	Function	Description
1	Sync Input	A narrow rectangular waveform applied to this input will synchronize the oscillator. A dc voltage within the range of 2.4 V to 5.5 V will inhibit the oscillator.
2	$C_T$	Timing capacitor $C_T$ connects from this pin to ground setting the free-running oscillator frequency range.
3	$R_T$	Resistor $R_T$ connects from this pin to ground precisely setting the charge current for $C_T$ . $R_T$ must be between 4.0 k and 16 k.
4	Voltage Feedback 1	This pin is the inverting input of Error Amplifier 1. It is normally connected to the switching power supply output through a resistor divider.
5	Compensation 1	This pin is the output of Error Amplifier 1 and is made available for loop compensation.
6	Current Sense 1	A voltage proportional to the inductor current is connected to this input. PWM 1 uses this information to terminate conduction of output switch Q1.
7	Drive Output 1	This pin directly drives the gate of a power MOSFET Q1. Peak currents up to 400 mA are sourced and sunk by this pin.
8	Gnd	This pin is the control circuitry ground return and is connected back to the source ground.
9	Drive Gnd	This pin is a separate power ground return that is connected back to the power source. It is used to reduce the effects of switching transient noise on the control circuitry.
10	Drive Output 2	This pin directly drives the gate of a power MOSFET Q2. Peak currents up to 400 mA are sourced and sunk by this pin.
11	Current Sense 2	A voltage proportional to inductor current is connected to this input. PWM 2 uses this information to terminate conduction of output switch Q2.
12	Compensation 2	This pin is the output of Error Amplifier 2 and is made available for loop compensation.
13	Voltage Feedback 2	This pin is the inverting input of Error Amplifier 2. It is normally connected to the switching power supply output through a resistor divider.
14	Drive Output 2 Enable	A logic low at this input disables Drive Output 2.
15	$V_{ref}$	This is the 5.0 V reference output. It can provide bias for any additional system circuitry.
16	$V_{CC}$	This pin is the positive supply of the control IC. The minimum operating voltage range after startup is 11 V to 15.5 V for the –H suffix, 8.2 V to 9.5 V for the –L suffix.

Figure 19. Adjustable Reduction of Clamp Level

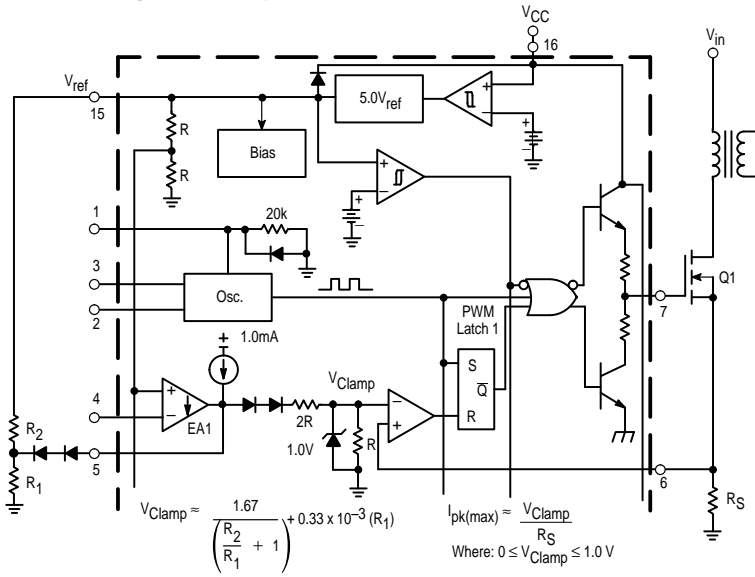

Figure 20. Soft-Start Circuit

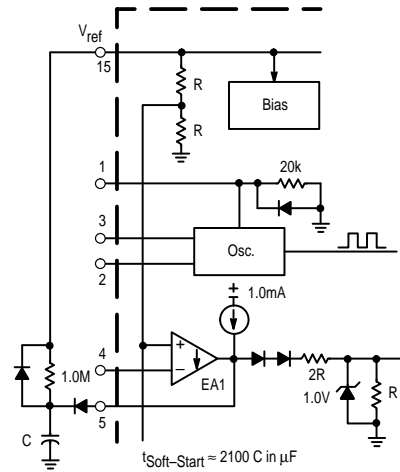

Figure 21. Adjustable Reduction of Clamp Level with Soft-Start

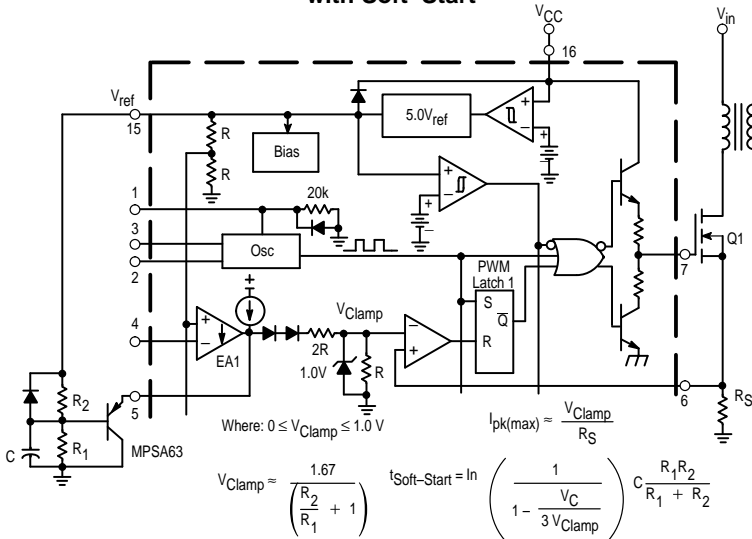
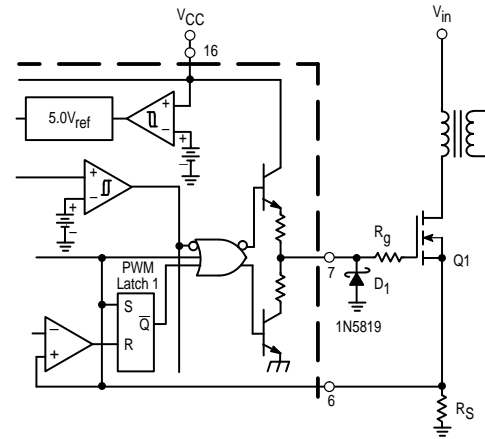
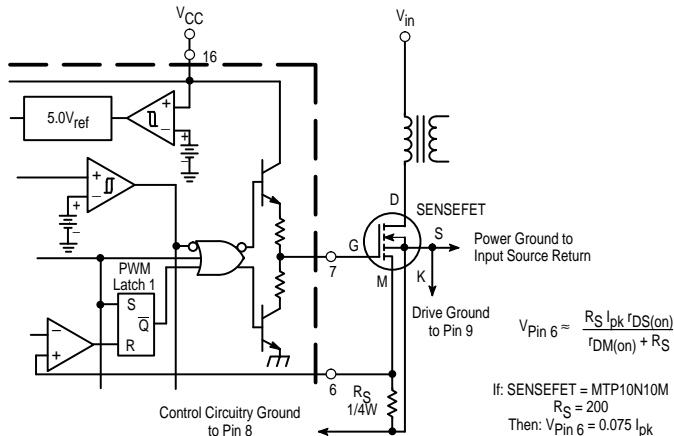

Figure 22. MOSFET Parasitic Oscillations



Series gate resistor  $R_g$  may be needed to damp high frequency parasitic oscillations caused by the MOSFET input capacitance and any series wiring inductance in the gate-source circuit.  $R_g$  will decrease the MOSFET switching speed. Schottky diode  $D_1$  is required if circuit ringing drives the output pin below ground.

Figure 23. Current Sensing Power MOSFET



Virtually lossless current sensing can be achieved with the implementation of a SENSEFET power switch. For proper operation during over current conditions, a reduction of the  $I_{pk(max)}$  clamp level must be implemented. Refer to Figures 19 and 21.

Figure 24. Current Waveform Spike Suppression

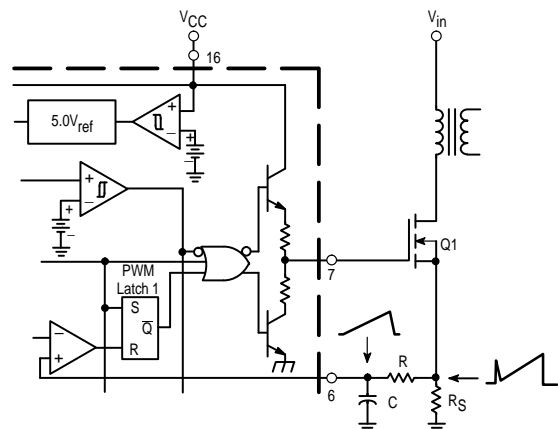

The addition of the RC filter will eliminate instability caused by the leading edge spike on the current waveform.

Figure 25. Bipolar Transistor Drive

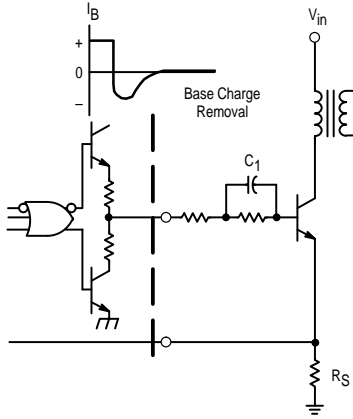

The totem-pole outputs can furnish negative base current for enhanced transistor turn-off, with the addition of capacitor C<sub>1</sub>.

Figure 26. Isolated MOSFET Drive

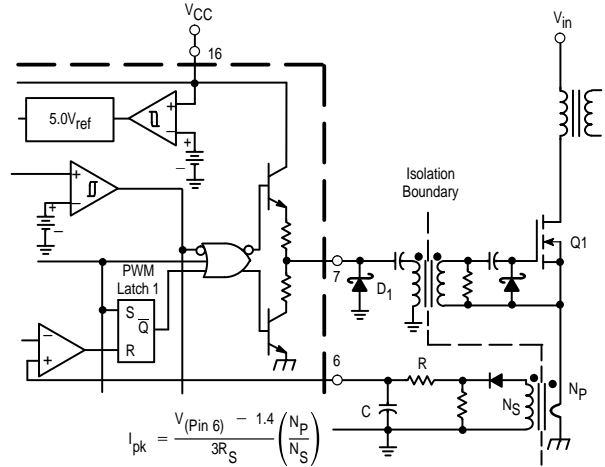
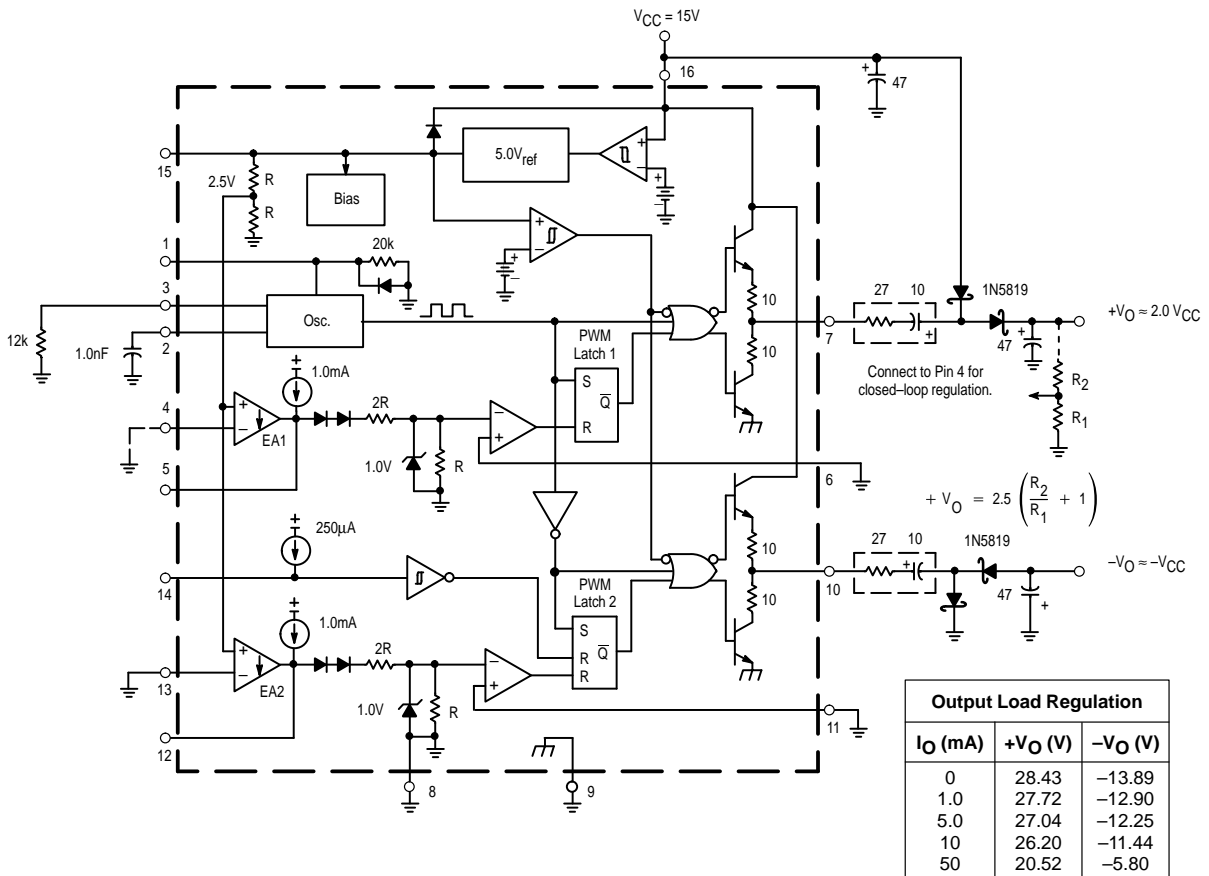

Figure 27. Dual Charge Pump Converter



The capacitor's equivalent series resistance must limit the Drive Output current to 400 mA. An additional series resistor may be required when using tantalum or other low ESR capacitors. The positive output can provide excellent line and load regulation by connecting the R<sub>2</sub>/R<sub>1</sub> resistor divider as shown.





# MC34065-H, L MC33065-H, L OUTLINE DIMENSIONS

## P SUFFIX PLASTIC PACKAGE CASE 648-08 ISSUE R

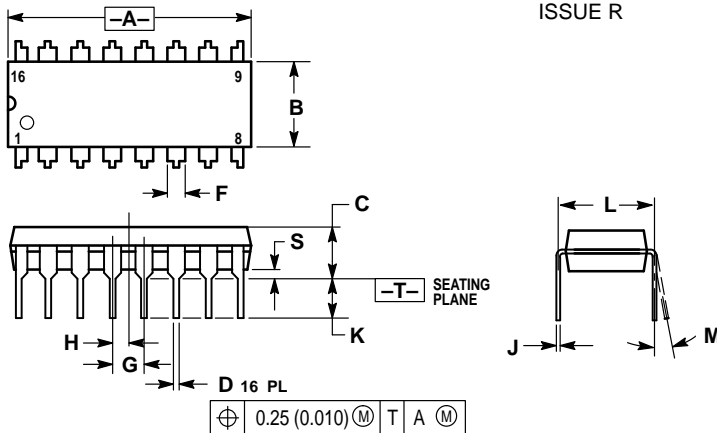

**NOTES:**

1. DIMENSIONING AND TOLERANCING PER ANSI Y14.5M, 1982.
2. CONTROLLING DIMENSION: INCH.
3. DIMENSION L TO CENTER OF LEADS WHEN FORMED PARALLEL.
4. DIMENSION B DOES NOT INCLUDE MOLD FLASH.
5. ROUNDED CORNERS OPTIONAL.

DIM	INCHES		MILLIMETERS	
	MIN	MAX	MIN	MAX
A	0.740	0.770	18.80	19.55
B	0.250	0.270	6.35	6.85
C	0.145	0.175	3.69	4.44
D	0.015	0.021	0.39	0.53
F	0.040	0.70	1.02	1.77
G	0.100 BSC		2.54 BSC	
H	0.050 BSC		1.27 BSC	
J	0.008	0.015	0.21	0.38
K	0.110	0.130	2.80	3.30
L	0.295	0.305	7.50	7.74
M	0° 10°		0° 10°	
S	0.020	0.040	0.51	1.01

## DW SUFFIX PLASTIC PACKAGE CASE 751G-02 (SOP-8+8L) ISSUE A

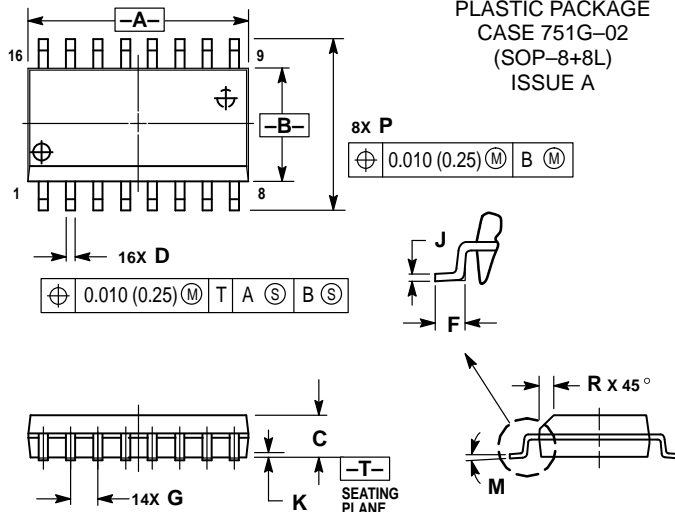

**NOTES:**

1. DIMENSIONING AND TOLERANCING PER ANSI Y14.5M, 1982.
2. CONTROLLING DIMENSION: MILLIMETER.
3. DIMENSIONS A AND B DO NOT INCLUDE MOLD PROTRUSION.
4. MAXIMUM MOLD PROTRUSION 0.15 (0.006) PER SIDE.
5. DIMENSION D DOES NOT INCLUDE DAMBAR PROTRUSION. ALLOWABLE DAMBAR PROTRUSION SHALL BE 0.13 (0.005) TOTAL IN EXCESS OF D DIMENSION AT MAXIMUM MATERIAL CONDITION.

DIM	MILLIMETERS		INCHES	
	MIN	MAX	MIN	MAX
A	10.15	10.45	0.400	0.411
B	7.40	7.60	0.292	0.299
C	2.35	2.65	0.093	0.104
D	0.35	0.49	0.014	0.019
F	0.50	0.90	0.020	0.035
G	1.27 BSC		0.050 BSC	
J	0.25	0.32	0.010	0.012
K	0.10	0.25	0.004	0.009
M	0° 7°		0° 7°	
P	10.05	10.55	0.395	0.415
R	0.25	0.75	0.010	0.029

Motorola reserves the right to make changes without further notice to any products herein. Motorola makes no warranty, representation or guarantee regarding the suitability of its products for any particular purpose, nor does Motorola assume any liability arising out of the application or use of any product or circuit, and specifically disclaims any and all liability, including without limitation consequential or incidental damages. "Typical" parameters which may be provided in Motorola data sheets and/or specifications can and do vary in different applications and actual performance may vary over time. All operating parameters, including "Typicals" must be validated for each customer application by customer's technical experts. Motorola does not convey any license under its patent rights nor the rights of others. Motorola products are not designed, intended, or authorized for use as components in systems intended for surgical implant into the body, or other applications intended to support or sustain life, or for any other application in which the failure of the Motorola product could create a situation where personal injury or death may occur. Should Buyer purchase or use Motorola products for any such unintended or unauthorized application, Buyer shall indemnify and hold Motorola and its officers, employees, subsidiaries, affiliates, and distributors harmless against all claims, costs, damages, and expenses, and reasonable attorney fees arising out of, directly or indirectly, any claim of personal injury or death associated with such unintended or unauthorized use, even if such claim alleges that Motorola was negligent regarding the design or manufacture of the part. Motorola and registered trademarks of Motorola, Inc. Motorola, Inc. is an Equal Opportunity/Affirmative Action Employer.

**How to reach us:**

**USA/EUROPE/Locations Not Listed:** Motorola Literature Distribution; P.O. Box 20912; Phoenix, Arizona 85036. 1-800-441-2447 or 602-303-5454

**MFAX:** RMFAX0@email.sps.mot.com – TOUCHTONE 602-244-6609  
**INTERNET:** <http://Design-NET.com>

**JAPAN:** Nippon Motorola Ltd.; Tatsumi-SPD-JLDC, 6F Seibu-Butsuryu-Center, 3-14-2 Tatsumi Koto-Ku, Tokyo 135, Japan. 03-81-3521-8315

**ASIA/PACIFIC:** Motorola Semiconductors H.K. Ltd.; 8B Tai Ping Industrial Park, 51 Ting Kok Road, Tai Po, N.T., Hong Kong. 852-26629298

