

# 2.5V-12V Output MD1222N

## DESCRIPTION

The MD1222N is a high-efficiency step down DC-DC converter power integrated circuit with main MOSFET switch and synchronous rectification MOSFET. The MD1222N can deliver high efficiency over a wide input voltage range. This device has output voltage digitally selectable from 2.5V to 12V. With the MD1222N you can construct a complete DC-DC converter using only a few external components. Featuring an SSOP 32-pin surface mount package, the MD1222N allows you to incorporate a very small and thin power supply on your circuit board.

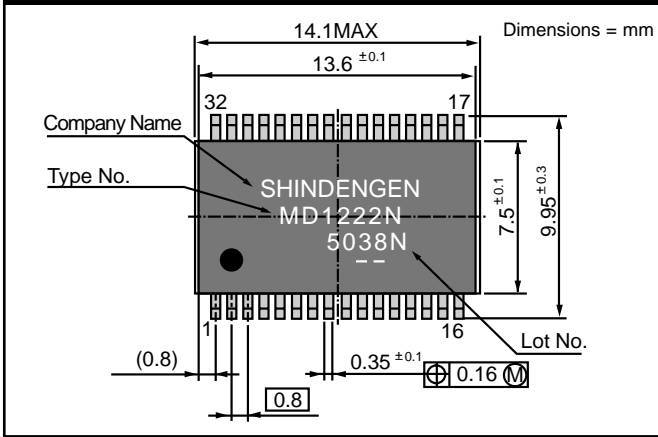

## BLOCK DIAGRAM

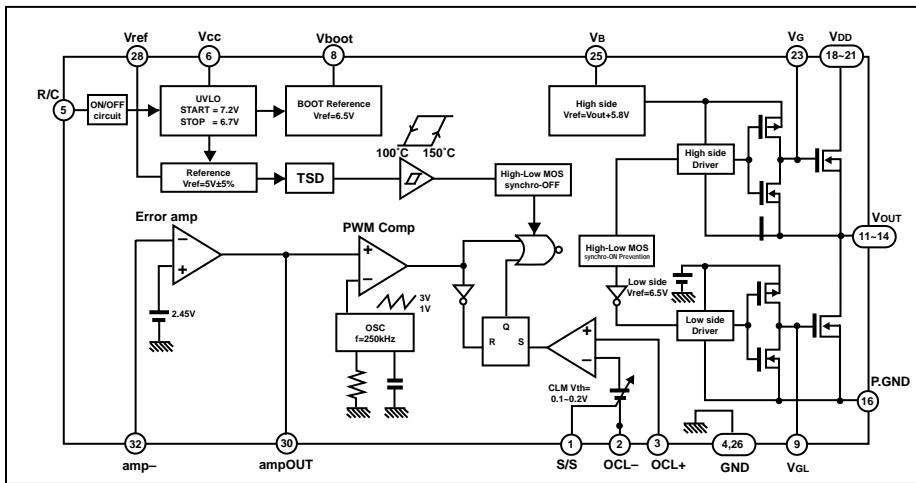

## FEATURES

- High efficiency
- Wide input voltage load range  
8VDC to 20VDC  
Up to 5ADC
- Output voltage selectable function  
2.5V to 12V
- Internal Switching power device  
Main MOSFET for switch and  
synchronous rectification MOSFET
- Fixed 250kHz PWM frequency  
(Without external resistor and capacitor)
- Overcurrent protection
- Under- or low-input voltage protection
- Thermal shutdown function
- Remote control ON/OFF

## PIN ASSIGNMENT

Pin#	Symbol	Function description
1	S/S	Capacitor for softstart
2	OCL-	Overcurrent protection (OCL) (-)
3	OCL+	Overcurrent protection (OCL) (+)
4	GND	Signal GND
5	R/C	Remote ON/OFF control terminal
6	Vcc	Input voltage
7	N/C	Non-connection
8	Vboot	High side drive supply for main MOS
9	VGL	Low side MOSFET gate terminal
10	N/C	Non-connection
11 - 14	Vout	Power stage output
15	N/C	Non-connection
16	P.GND	Power GND
17	N/C	Non-connection
18 - 21	VDD	Drain of main MOS Switch
22	N/C	Non-connection
23	VGH	Main switch high side MOSFET gate terminal
24	N/C	Non-connection
25	Vb	Bootstrap capacitor between VB and VOUT
26	GND	Signal GND
27	VTS	Output voltage selectable terminal
28	Vref	Internal voltage reference
29	N/C	Non-connection

30	AmpOUT	Error Amp out
31	N/C	Non-connection
32	amp-	Error Amp (-) input

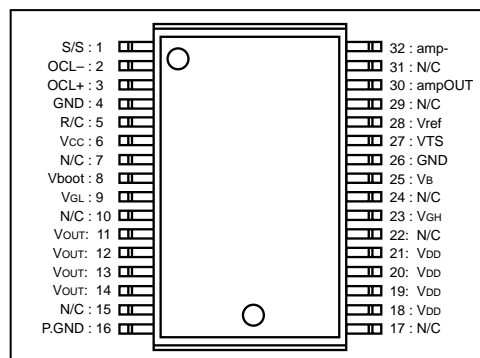

- **Vref** - Temperature compensated internal voltage. You can pull 1mA maximum for external circuit.
- **OSC** - MCD1222N uses internal oscillator without external component. Frequency (Saw tooth wave form) is trimmed to 250kHz on chip.
- **Error Amp** - Error Amp detects output voltage of DC-DC converter and controls PWM signal. You can adjust the loop gain when you connect feedback resistor and capacitor between AmpOUT and Amp (-). It will provide stable phase compensation.
- **Overcurrent protection** - MD1222N uses pulse-by-pulse current protection. Current will be sensed voltage drop of external current sensing resistor. Threshold of OCL is 0.19V.

## ABSOLUTE MAXIMUM RATINGS

(Ta=25°C)

Parameter	Symbol	Rating	Units
Line voltage	V <sub>IN</sub>	22	V
Output MOS input voltage	V <sub>DD</sub>	22	V
Output current (ave)	I <sub>OUTAVE</sub>	5	A
Output current (peak)	I <sub>OUTPEAK</sub>	6	A
OCL-, OCL+ terminal voltage	V <sub>OCL</sub>	5.5	V
Remote control voltage	V <sub>RC</sub>	5.5	V
Storage temperature	T <sub>stg</sub>	-40 ~ 150	°C
Junction temperature	T <sub>J</sub>	150	°C

## RECOMMENDED OPERATION CONDITIONS

Parameter	Recommendation	Units
Input voltage	8 ~ 20	V
Output voltage setting range	2.5-12	V
Operation temperature	-10 ~ 80	°C

## OUTPUT CURRENT DERATING FOR 5.3V OR HIGHER OUTPUT

Output setting voltage	Output current
2.5V ~5.3V	5A
≤8V	3A
≤12V	2.5A

## ELECTRIC CHARACTERISTICS

(Ta=25°C)

Parameter	Symbol	Conditions	MIN	TYP	MAX	Units
High side MOS Drain-source breakdown voltage	V <sub>dss</sub>	I <sub>D</sub> =1mA, V <sub>GS</sub> =0V	22	-	-	V
High side MOS Drain interruption current	I <sub>dss</sub>	V <sub>DS</sub> =20V, V <sub>GS</sub> =0V	-	-	10	μA
High side MOS Drain-source ON resistance	R <sub>on</sub>	I <sub>D</sub> =1.2A, V <sub>GS</sub> =4.5V	-	22	55	mΩ
High side MOS Source-drain Di forward voltage	V <sub>SD</sub>	I <sub>S</sub> =1.2A, V <sub>DS</sub> =0V	-	-	1.5	V
Low side MOS Drain-source breakdown voltage	V <sub>dss</sub>	I <sub>D</sub> =1mA, V <sub>GS</sub> =0V	22	-	-	V
Low side MOS Drain interruption current	I <sub>dss</sub>	V <sub>DS</sub> =20V, V <sub>GS</sub> =0V	-	-	10	μA
Low side MOS Drain-source ON resistance	R <sub>on</sub>	I <sub>D</sub> =1.2A, V <sub>GS</sub> =4.5V	-	22	55	mΩ
Low side MOS Source-drain Di forward voltage	V <sub>SD</sub>	I <sub>S</sub> =1.2A, V <sub>DS</sub> =0V	-	-	1.5	V
Start voltage	V <sub>cc_start</sub>	-	6.5	7.2	7.9	V
Stop voltage	V <sub>cc_stop</sub>	-	6.0	6.7	7.4	V
Stop-start voltage hysteresis	V <sub>cc_hys</sub>	-	-	0.5	-	V
Current consumption	I <sub>cc</sub>	V <sub>cc</sub> =8V ~ 20V	-	10	13	mA
Current consumption with remote control OFF	I <sub>cc_off</sub>	V <sub>cc</sub> =8V ~ 20V	-	1.2	1.5	mA
Remote control terminal ON voltage	V <sub>RC_ON</sub>	V <sub>cc</sub> =8V ~ 20V	-0.2	-	0.5	V
Remote control terminal OFF voltage	V <sub>RC_OFF</sub>	V <sub>cc</sub> =8V ~ 20V	2.5	-	5.3	V
Remote control terminal shorted voltage	I <sub>RC</sub>	V <sub>cc</sub> =8V ~ 20V	-	-	250	μA
BOOT terminal voltage	V <sub>boot</sub>	V <sub>cc</sub> =12V	5.4	6.5	7.6	V
Internal reference voltage	V <sub>ref</sub>	V <sub>cc</sub> =8V ~ 20V	4.75	5	5.25	V
Internal oscillation frequency	f <sub>osc</sub>	V <sub>cc</sub> =12V	212.5	250	287.5	kHz
Overcurrent threshold voltage	V <sub>th_OCL</sub>	V <sub>cc</sub> =12V	0.162	0.19	0.218	V
Softstart terminal current	I <sub>S/S</sub>	V <sub>cc</sub> =12V	-20	-12.5	-5	μA
Error amplifier reference voltage	V <sub>amp</sub>	V <sub>cc</sub> =8V~ 20V	2.4	2.45	2.5	V
Overcurrent protection operating temperature	T <sub>TSD</sub>	-	-	150	-	°C