

TOSHIBA Transistor Silicon NPN Epitaxial Type (PCT Process)

## RN1101, RN1102, RN1103 RN1104, RN1105, RN1106

Switching, Inverter Circuit, Interface Circuit  
And Driver Circuit Applications

Unit in mm

- With built-in bias resistors
- Simplify circuit design
- Reduce a quantity of parts and manufacturing process
- Complementary to RN2101~RN2106

### Equivalent Circuit and Bias Resister Values

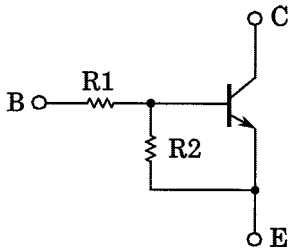

Type No.	R1 (kΩ)	R2 (kΩ)
RN1101	4.7	4.7
RN1102	10	10
RN1103	22	22
RN1104	47	47
RN1105	2.2	47
RN1106	4.7	47

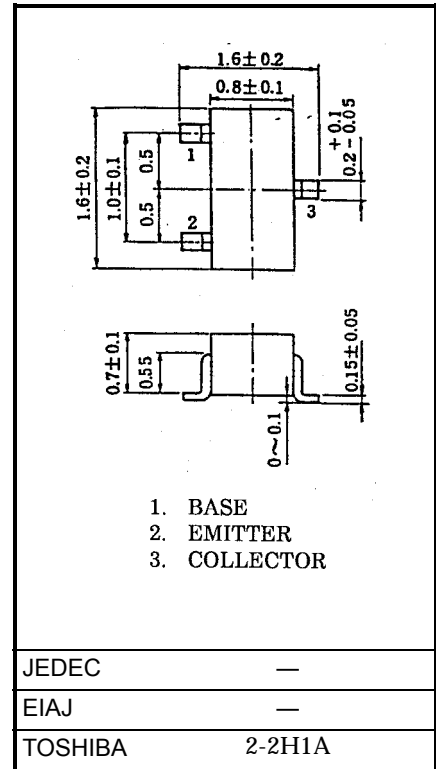

Weight: 2.4mg

### Maximum Ratings (Ta = 25°C)

Characteristic	Symbol	Rating	Unit	
Collector-base voltage	RN1101~1106	$V_{CBO}$	50	V
Collector-emitter voltage		$V_{CEO}$	50	V
Emitter-base voltage	RN1101~1104	$V_{EBO}$	10	V
	RN1105, 1106		5	
Collector current	RN1101~1106	$I_C$	100	mA
Collector power dissipation		$P_C$	100	mW
Junction temperature		$T_j$	150	°C
Storage temperature range		$T_{stg}$	-55~150	°C

961001EAA2

- TOSHIBA is continually working to improve the quality and the reliability of its products. Nevertheless, semiconductor devices in general can malfunction or fail due to their inherent electrical sensitivity and vulnerability to physical stress. It is the responsibility of the buyer, when utilizing TOSHIBA products, to observe standards of safety, and to avoid situations in which a malfunction or failure of a TOSHIBA product could cause loss of human life, bodily injury or damage to property. In developing your designs, please ensure that TOSHIBA products are used within specified operating ranges as set forth in the most recent products specifications. Also, please keep in mind the precautions and conditions set forth in the TOSHIBA Semiconductor Reliability Handbook.
- The information contained herein is presented only as a guide for the applications of our products. No responsibility is assumed by TOSHIBA CORPORATION for any infringements of intellectual property or other rights of the third parties which may result from its use. No license is granted by implication or otherwise under any intellectual property or other rights of TOSHIBA CORPORATION or others.
- The information contained herein is subject to change without notice.

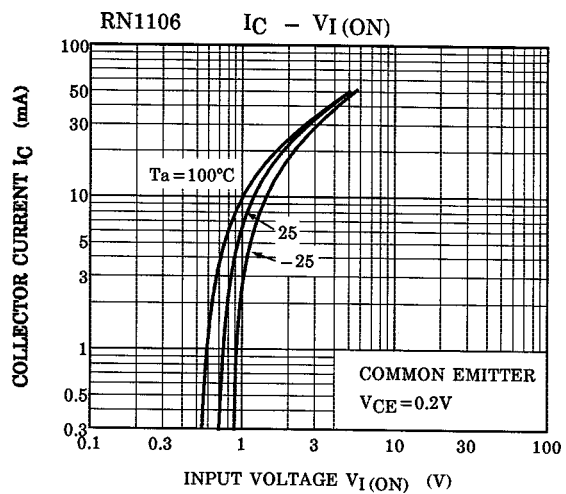
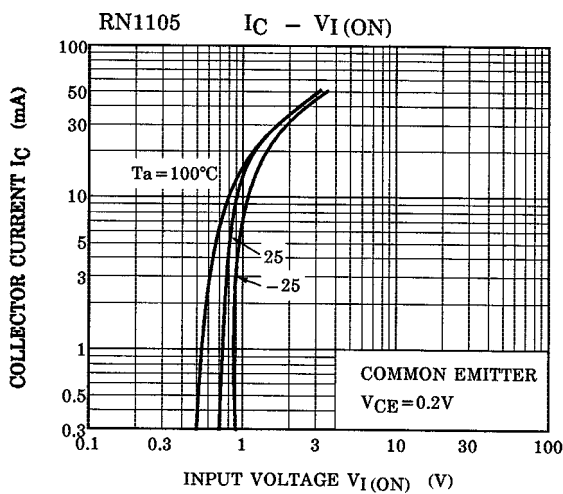
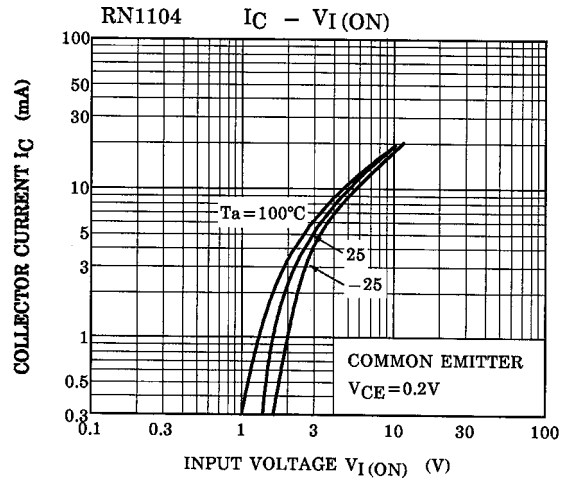
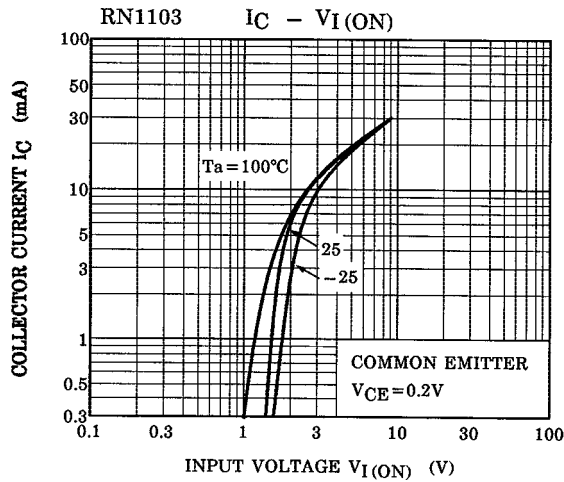
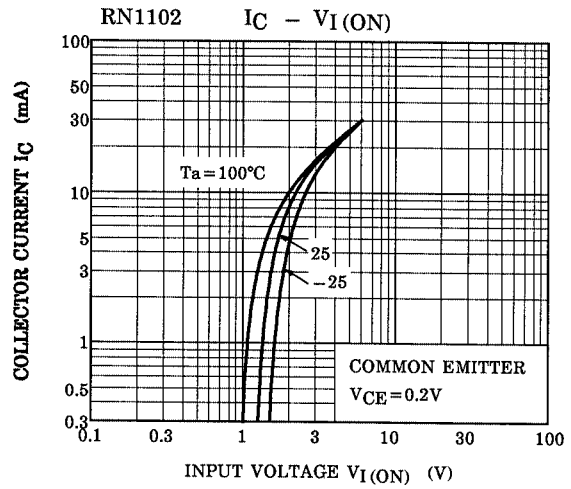
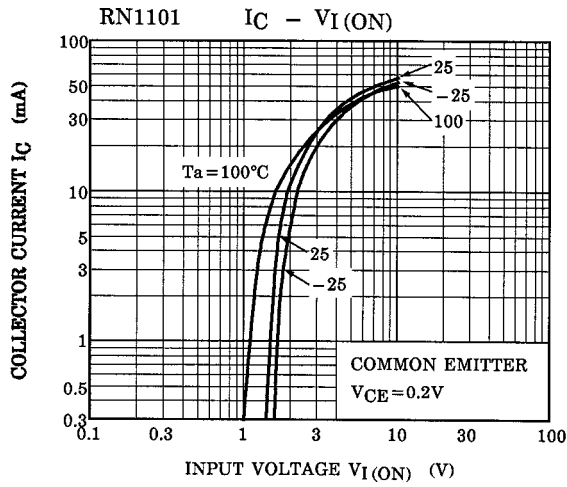

**Electrical Characteristics (Ta = 25°C)**

Characteristic		Symbol	Test Circuit	Test Condition	Min	Typ.	Max	Unit
Collector cut-off current	RN1101~1106	$I_{CBO}$	—	$V_{CB} = 50V, I_E = 0$	—	—	100	nA
		$I_{CEO}$		$V_{CE} = 50V, I_B = 0$	—	—	500	
Emitter cut-off current	RN1101	$I_{EBO}$	—	$V_{EB} = 10V, I_C = 0$	0.82	—	1.52	mA
	RN1102				0.38	—	0.71	
	RN1103				0.17	—	0.33	
	RN1104			0.082	—	0.15		
	RN1105			$V_{EB} = 5V, I_C = 0$	0.078	—	0.145	
	RN1106				0.074	—	0.138	
DC current gain	RN1101	$h_{FE}$	—	$V_{CE} = 5V, I_C = 10mA$	30	—	—	—
	RN1102				50	—	—	
	RN1103				70	—	—	
	RN1104				80	—	—	
	RN1105				80	—	—	
	RN1106				80	—	—	
Collector-emitter saturation voltage	RN1101~1106	$V_{CE(sat)}$	—	$I_C = 5mA, I_B = 0.25mA$	—	0.1	0.3	V
Input voltage (ON)	RN1101	$V_{I(ON)}$	—	$V_{CE} = 0.2V, I_C = 5mA$	1.1	—	2.0	V
	RN1102				1.2	—	2.4	
	RN1103				1.3	—	3.0	
	RN1104				1.5	—	5.0	
	RN1105				0.6	—	1.1	
	RN1106				0.7	—	1.3	
Input voltage (OFF)	RN1101~1104	$V_{I(OFF)}$	—	$V_{CE} = 5V, I_C = 0.1mA$	1.0	—	1.5	V
	RN1105, 1106				0.5	—	0.8	
Transition frequency	RN1101~1106	$f_T$	—	$V_{CE} = 10V, I_C = 5mA$	—	250	—	MHz
Collector Output capacitance	RN1101~1106	$C_{ob}$	—	$V_{CB} = 10V, I_E = 0, f = 1MHz$	—	3	6	pF
Input resistor	RN1101	R1	—		3.29	4.7	6.11	kΩ
	RN1102				7	10	13	
	RN1103				15.4	22	28.6	
	RN1104				32.9	47	61.1	
	RN1105				1.54	2.2	2.86	
	RN1106				3.29	4.7	6.11	
Resistor ratio	RN1101~1104	R1/R2	—		0.9	1.0	1.1	—
	RN1105				0.0421	0.0468	0.0515	
	RN1106				0.09	0.1	0.11	

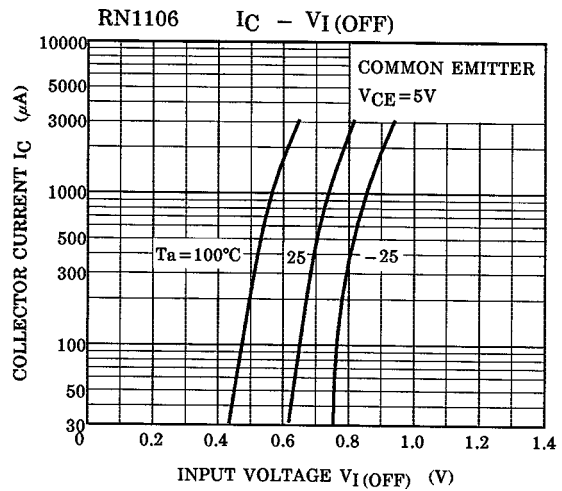
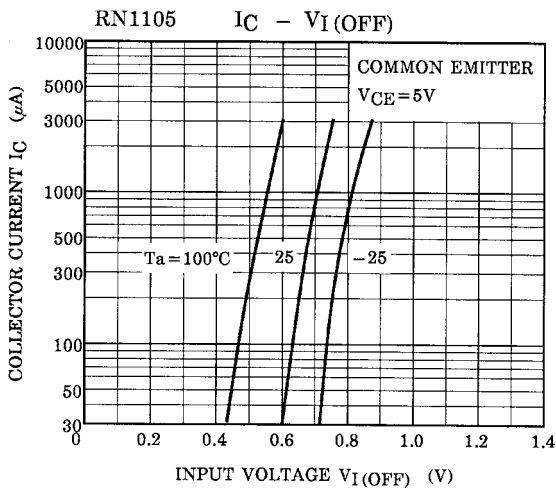
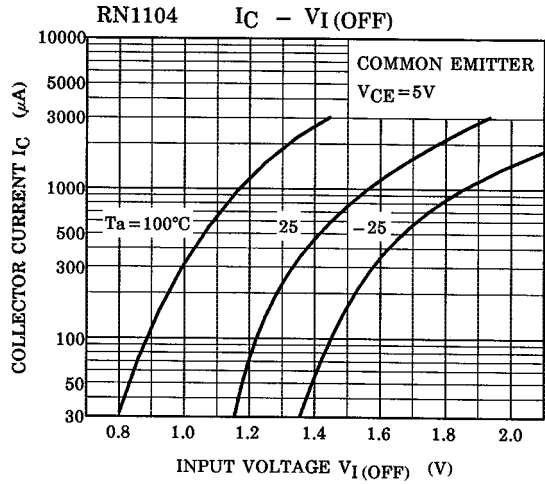
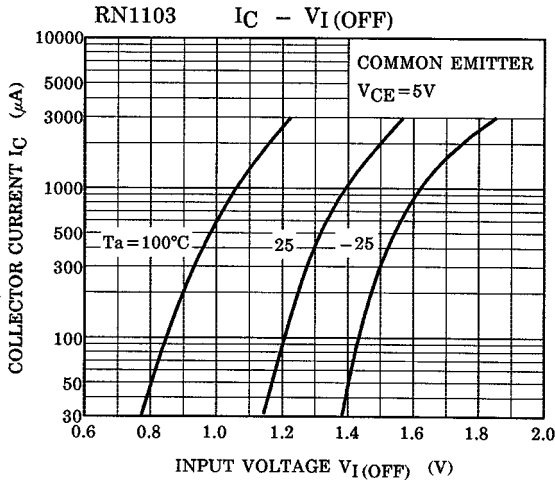
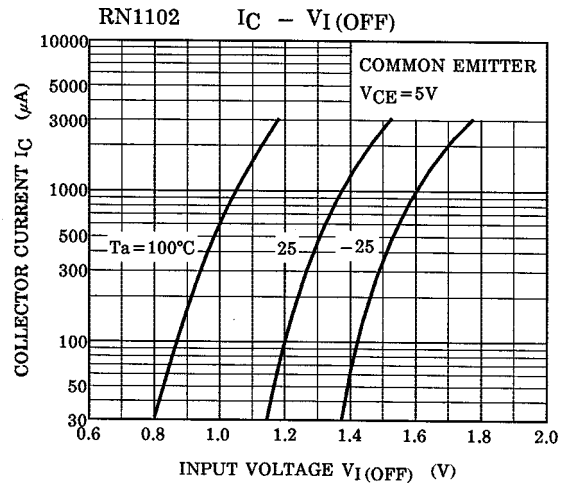
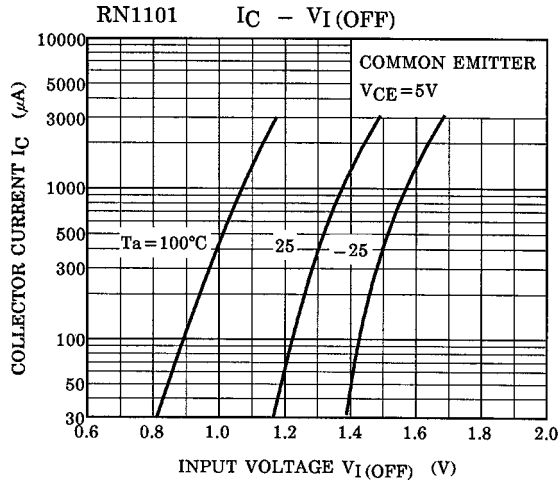

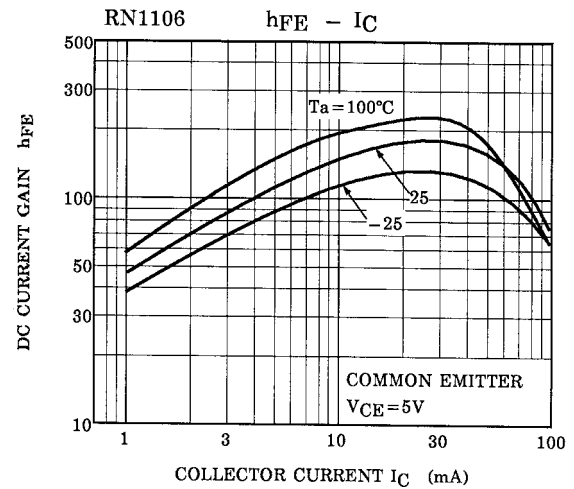
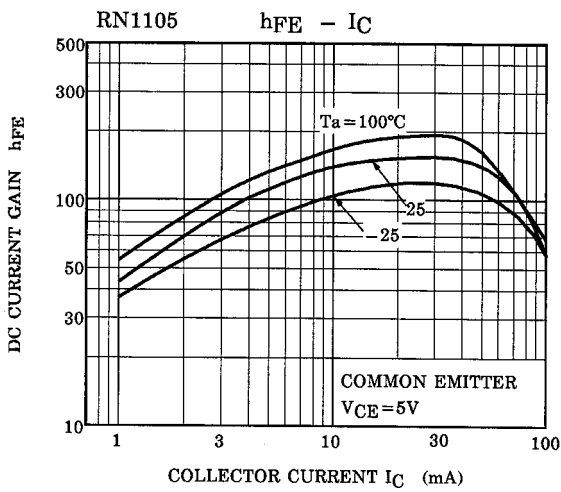
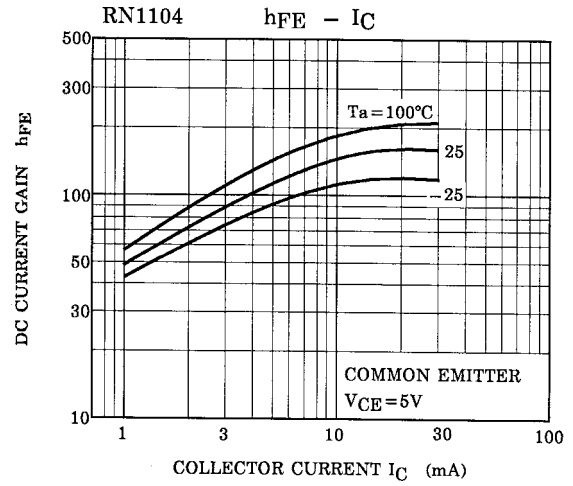
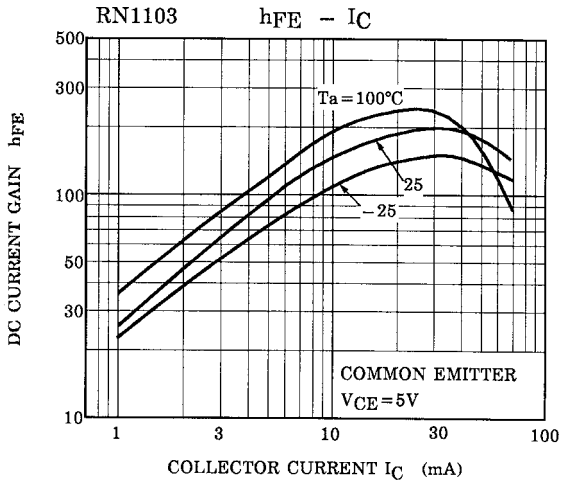
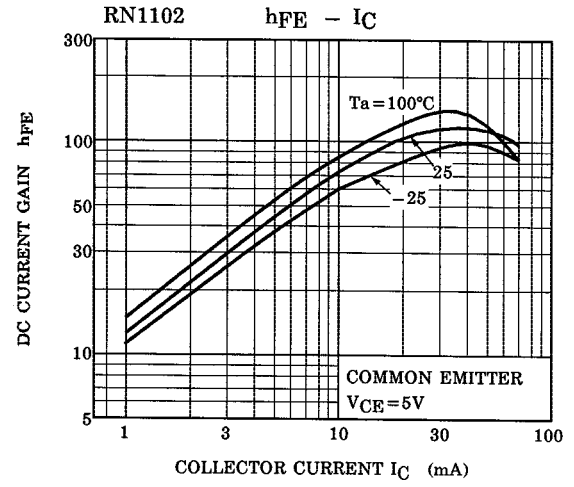
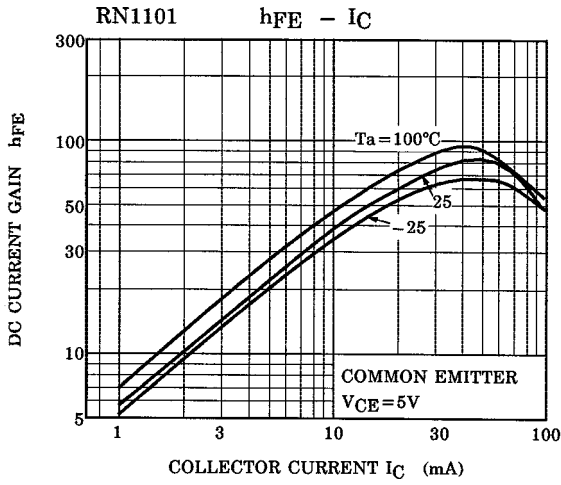

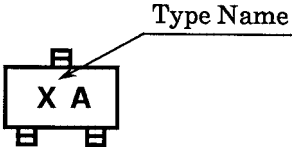
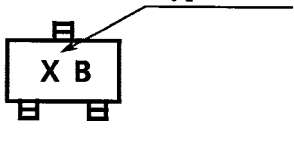
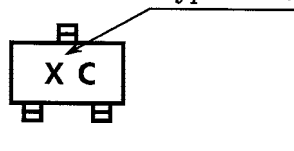
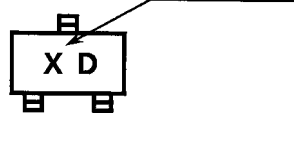

Type Name	Marking
RN1101	
RN1102	
RN1103	
RN1104	
RN1105	
RN1106	