

TOSHIBA Transistor Silicon PNP Epitaxial Type (PCT Process)

RN2401,RN2402,RN2403 RN2404,RN2405,RN2406

Switching, Inverter Circuit, Interface Circuit
And Driver Circuit Applications

Unit in mm

- With built-in bias resistors
- Simplify circuit design
- Reduce a quantity of parts and manufacturing process
- Complementary to RN1401~1406

Equivalent Circuit

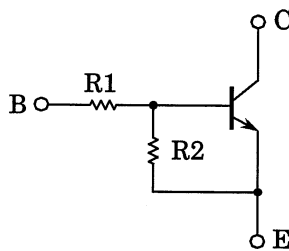

Bias Resistor Values

Type No.	R1 (kΩ)	R2 (kΩ)
RN2401	4.7	4.7
RN2402	10	10
RN2403	22	22
RN2404	47	47
RN2405	2.2	47
RN2406	4.7	47

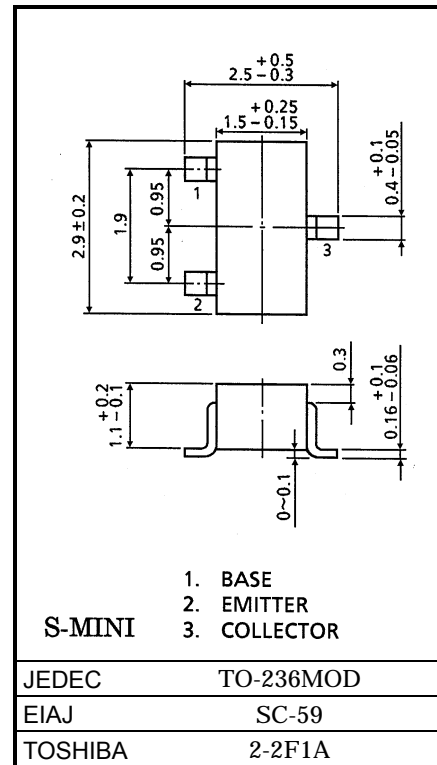

Weight: 0.012g

Maximum Ratings (Ta = 25°C)

Characteristic	Symbol	Rating	Unit
Collector-base voltage	V _{CB0}	-50	V
Collector-emitter voltage			
Emitter-base voltage	V _{EB0}	-10	V
		-5	V
Collector current	I _C	-100	mA
Collector power dissipation	P _C	200	mW
Junction temperature	T _j	150	°C
Storage temperature range	T _{stg}	-55~150	°C

961001EAA2

- TOSHIBA is continually working to improve the quality and the reliability of its products. Nevertheless, semiconductor devices in general can malfunction or fail due to their inherent electrical sensitivity and vulnerability to physical stress. It is the responsibility of the buyer, when utilizing TOSHIBA products, to observe standards of safety, and to avoid situations in which a malfunction or failure of a TOSHIBA product could cause loss of human life, bodily injury or damage to property. In developing your designs, please ensure that TOSHIBA products are used within specified operating ranges as set forth in the most recent products specifications. Also, please keep in mind the precautions and conditions set forth in the TOSHIBA Semiconductor Reliability Handbook.
- The information contained herein is presented only as a guide for the applications of our products. No responsibility is assumed by TOSHIBA CORPORATION for any infringements of intellectual property or other rights of the third parties which may result from its use. No license is granted by implication or otherwise under any intellectual property or other rights of TOSHIBA CORPORATION or others.
- The information contained herein is subject to change without notice.

Electrical Characteristics (Ta = 25°C)

Characteristic		Symbol	Test Circuit	Test Condition	Min	Typ.	Max	Unit
Collector cut-off current	RN2401~2406	I_{CBO}	—	$V_{CB} = -50V, I_E = 0$	—	—	-100	nA
		I_{CEO}	—	$V_{CE} = -50V, I_B = 0$	—	—	-500	
Emitter cut-off current	RN2401	I_{EBO}	—	$V_{EB} = -10V, I_C = 0$	-0.82	—	-1.52	mA
	RN2402		—		-0.38	—	-0.71	
	RN2403		—		-0.17	—	-0.33	
	RN2404		—	-0.082	—	-0.15		
	RN2405		—	$V_{EB} = -5V, I_C = 0$	-0.078	—	-0.145	
	RN2406		—		-0.074	—	-0.138	
DC current gain	RN2401	h_{FE}	—	$V_{CE} = -5V$ $I_C = -10mA$	30	—	—	—
	RN2402		—		50	—	—	
	RN2403		—		70	—	—	
	RN2404		—		80	—	—	
	RN2405		—		80	—	—	
	RN2406		—		80	—	—	
Collector-emitter saturation voltage	RN2401~2406	$V_{CE(sat)}$	—	$I_C = -5mA$ $I_B = -0.25mA$	—	-0.1	-0.3	V
Input voltage (ON)	RN2401	$V_{I(ON)}$	—	$V_{CE} = -0.2V$ $I_C = -5mA$	-1.1	—	-2.0	V
	RN2402		—		-1.2	—	-2.4	
	RN2403		—		-1.3	—	-3.0	
	RN2404		—		-1.5	—	-5.0	
	RN2405		—		-0.6	—	-1.1	
	RN2406		—		-0.7	—	-1.3	
Input voltage (OFF)	RN2401~2404	$V_{I(OFF)}$	—	$V_{CE} = -5V,$ $I_C = -0.1mA$	-1.0	—	-1.5	V
	RN2405, 2406		—		-0.5	—	-0.8	
Translation frequency	RN2401~2406	f_T	—	$V_{CE} = -10V,$ $I_C = -5mA$	—	200	—	MHz
Collector output capacitance	RN2401~2406	C_{ob}	—	$V_{CB} = -10V, I_E = 0$ $f = 1MHz$	—	3	6	pF
Input resistor	RN2401	R1	—	—	3.29	4.7	6.11	kΩ
	RN2402		—		7	10	13	
	RN2403		—		15.4	22	28.6	
	RN2404		—		32.9	47	61.1	
	RN2405		—		1.54	2.2	2.86	
	RN2406		—		3.29	4.7	6.11	
Resistor ratio	RN2401~2404	R1/R2	—	—	0.9	1.0	1.1	—
	RN2405		—		0.0421	0.0468	0.0515	
	RN2406		—		0.09	0.1	0.11	

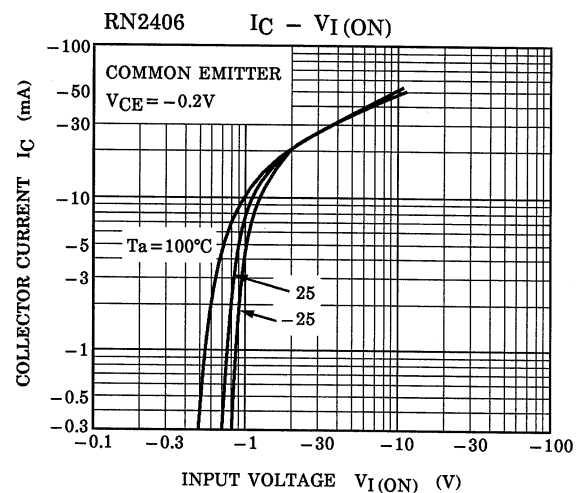
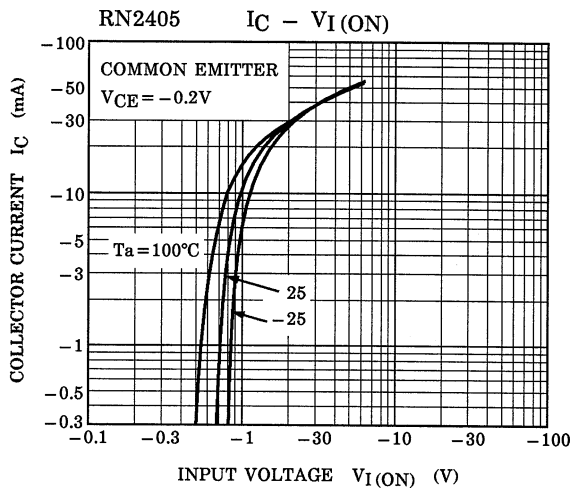
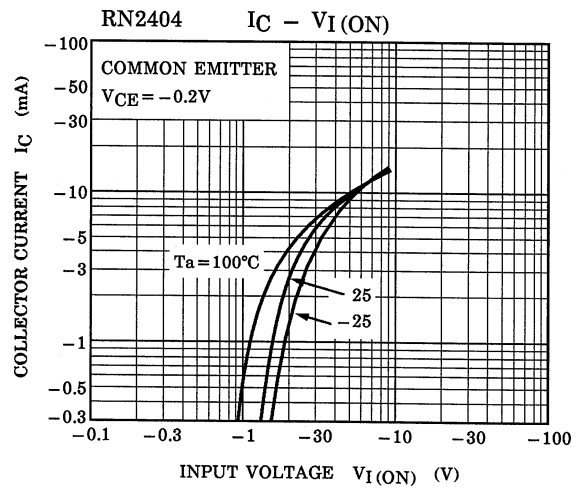
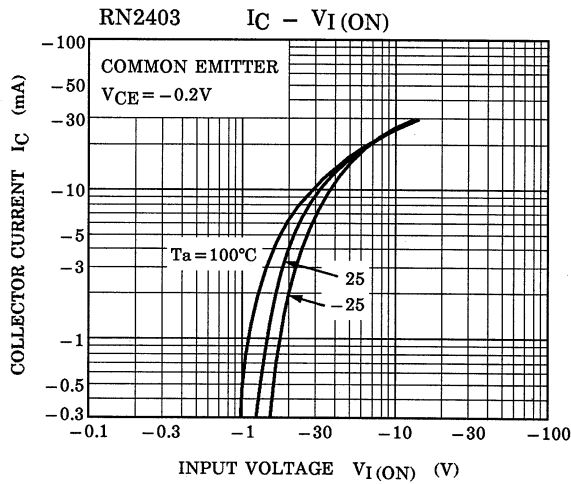
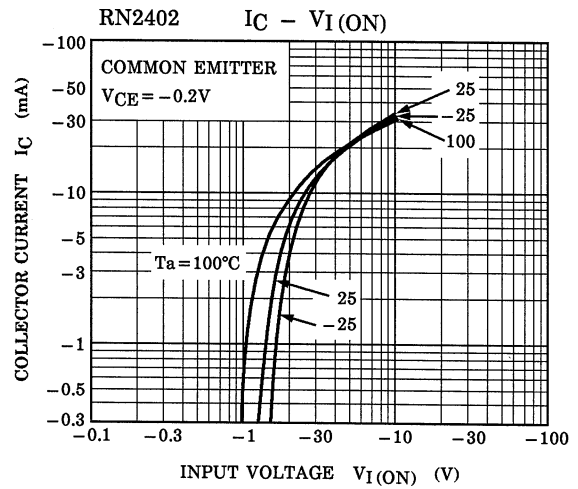
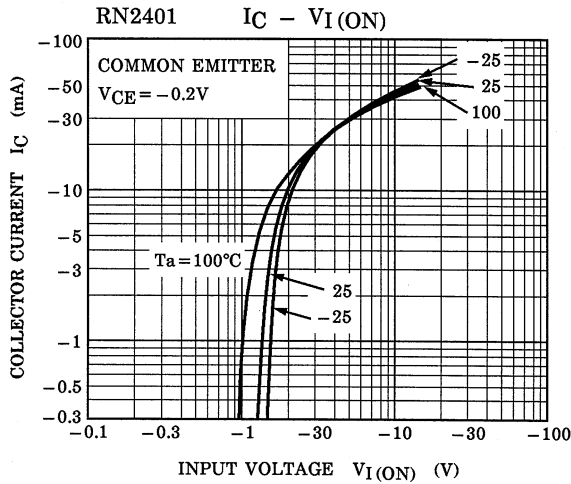

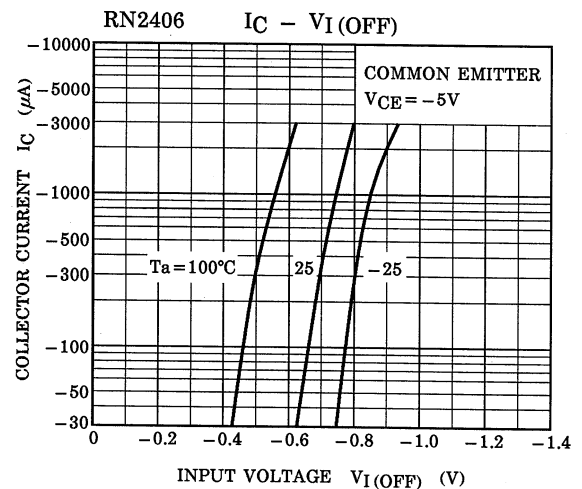
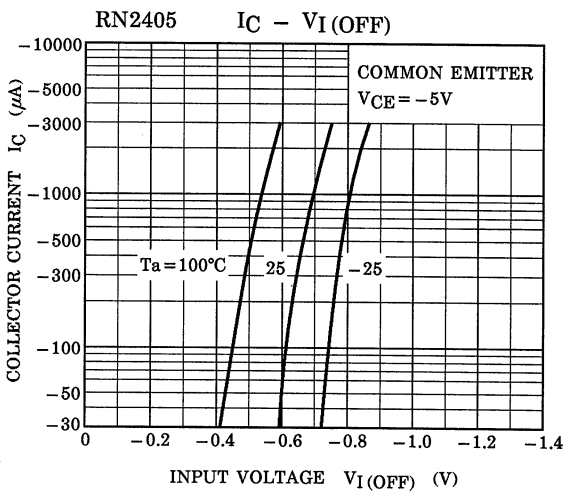
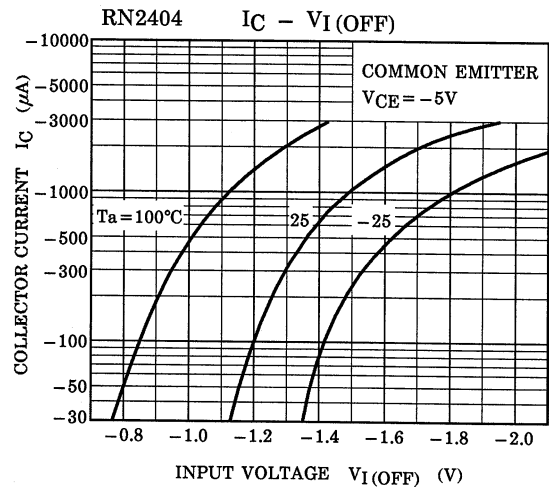
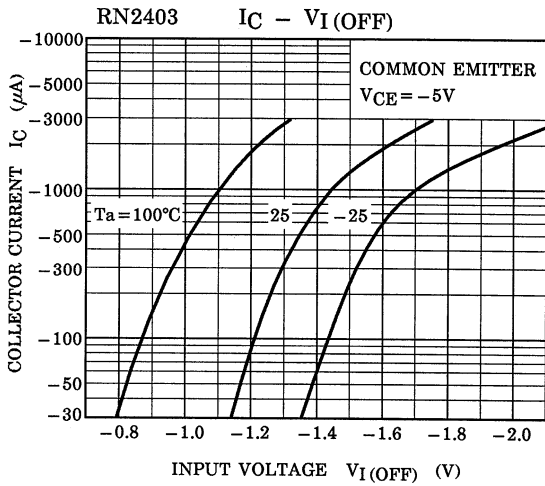
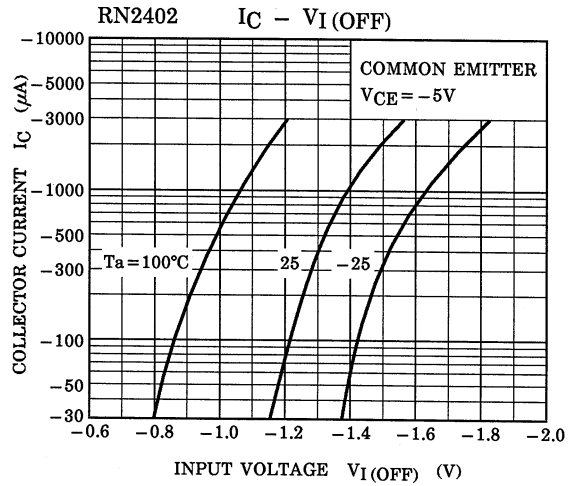
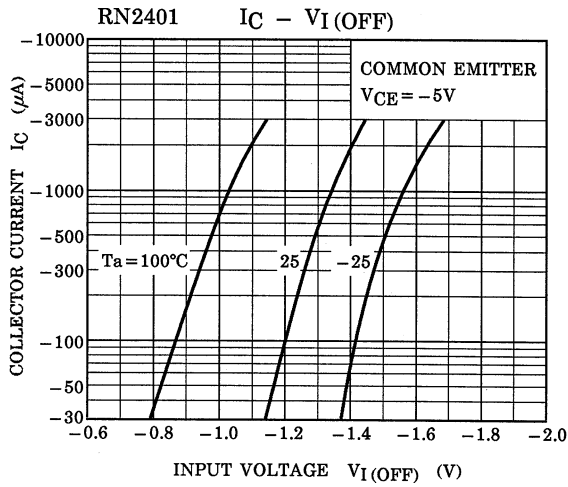

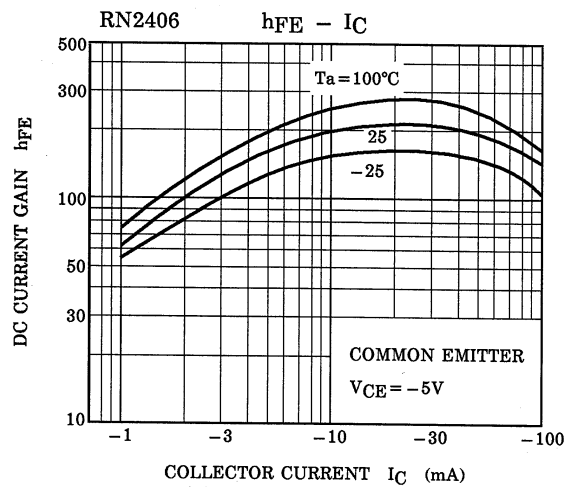
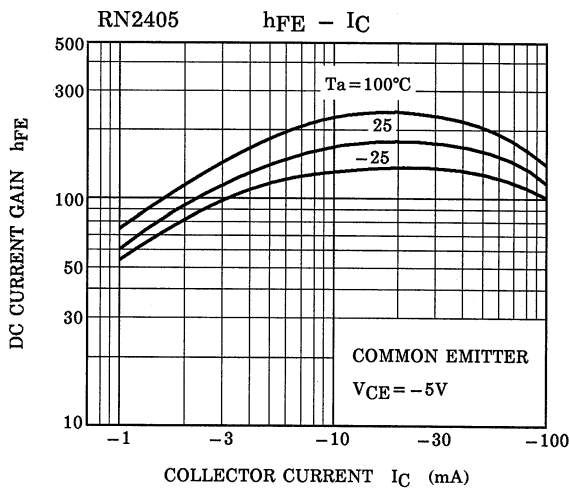
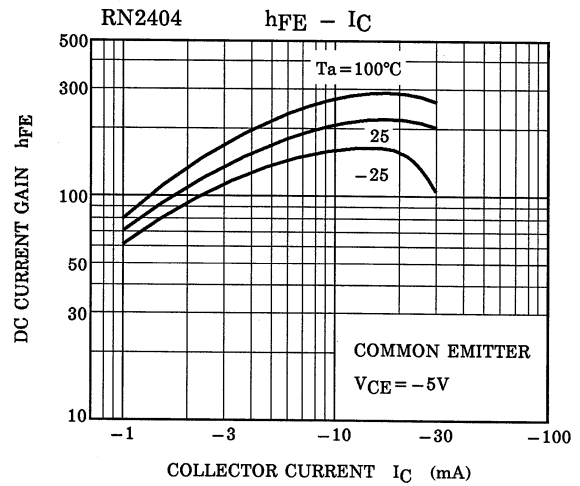
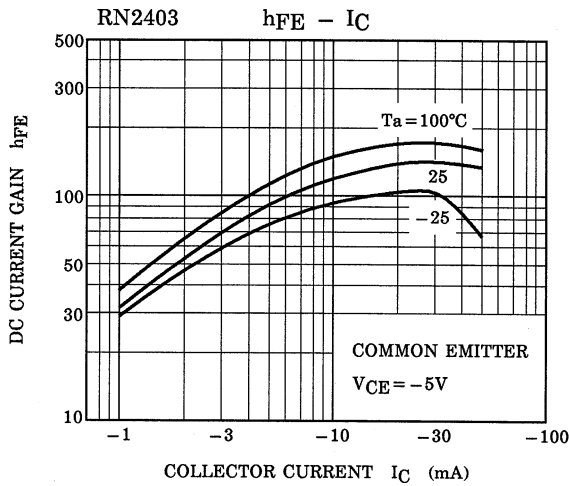
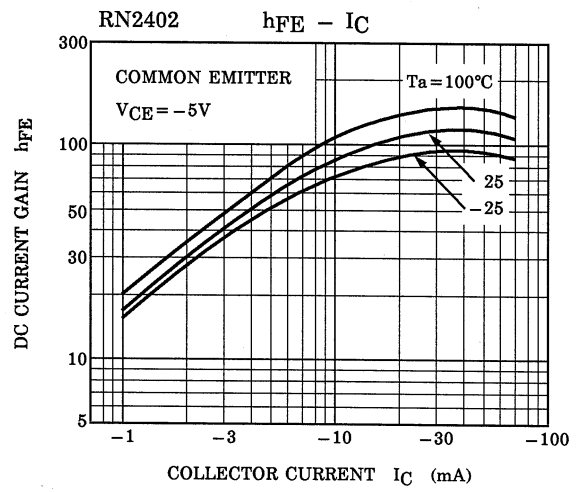
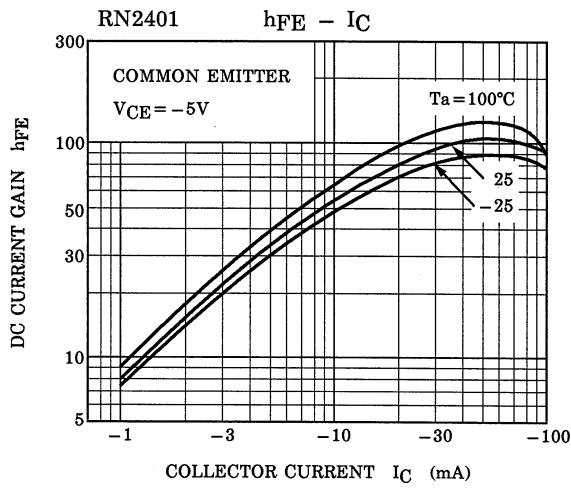

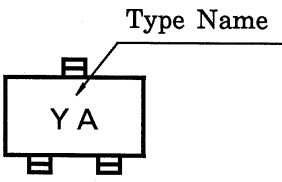
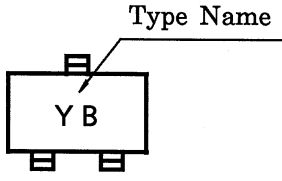
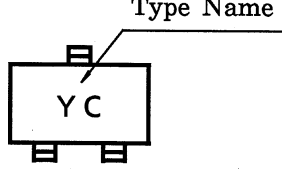
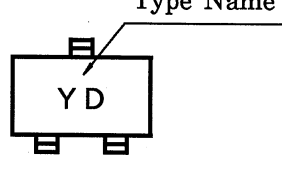
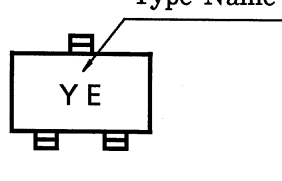
Type Name	Marking
RN2401	
RN2402	
RN2403	
RN2404	
RN2405	
RN2406	