

GENERAL PURPOSE DUAL BIPOLAR TIMERS

- LOW TURN OFF TIME
- MAXIMUM OPERATING FREQUENCY GREATER THAN 500kHz
- TIMING FROM MICROSECONDS TO HOURS
- OPERATES IN BOTH ASTABLE AND MONOSTABLE MODES
- HIGH OUTPUT CURRENT CAN SOURCE OR SINK 200mA
- ADJUSTABLE DUTY CYCLE
- TTL COMPATIBLE
- TEMPERATURE STABILITY OF 0.005% PER °C

DESCRIPTION

The NE556 dual monolithic timing circuit is a highly stable controller capable of producing accurate time delays or oscillation. In the time delay mode of operation, the time is precisely controlled by one external resistor and capacitor. For a stable operation as an oscillator, the free running frequency and the duty cycle are both accurately controlled with two external resistors and one capacitor. The circuit may be triggered and reset on falling waveforms, and the output structure can source or sink up to 200mA.

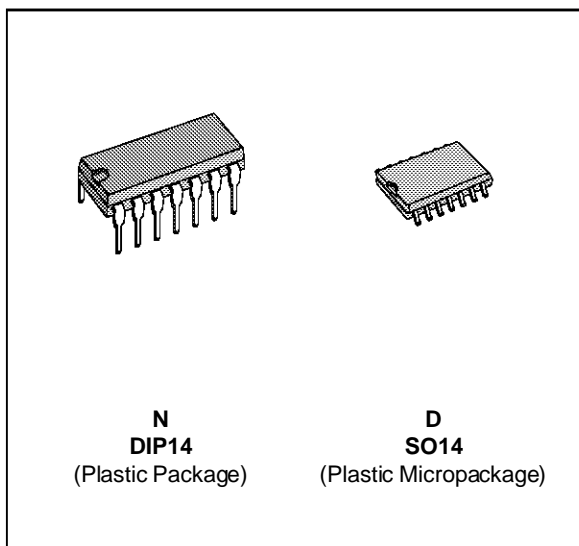

ORDER CODES

Part Number	Temperature Range	Package	
		N	D
NE556	0°C, 70°C	•	•
SA556	-40°C, 105°C	•	•
SE556	-55°C, 125°C	•	•

556-01.TBL

PIN CONNECTIONS (top view)

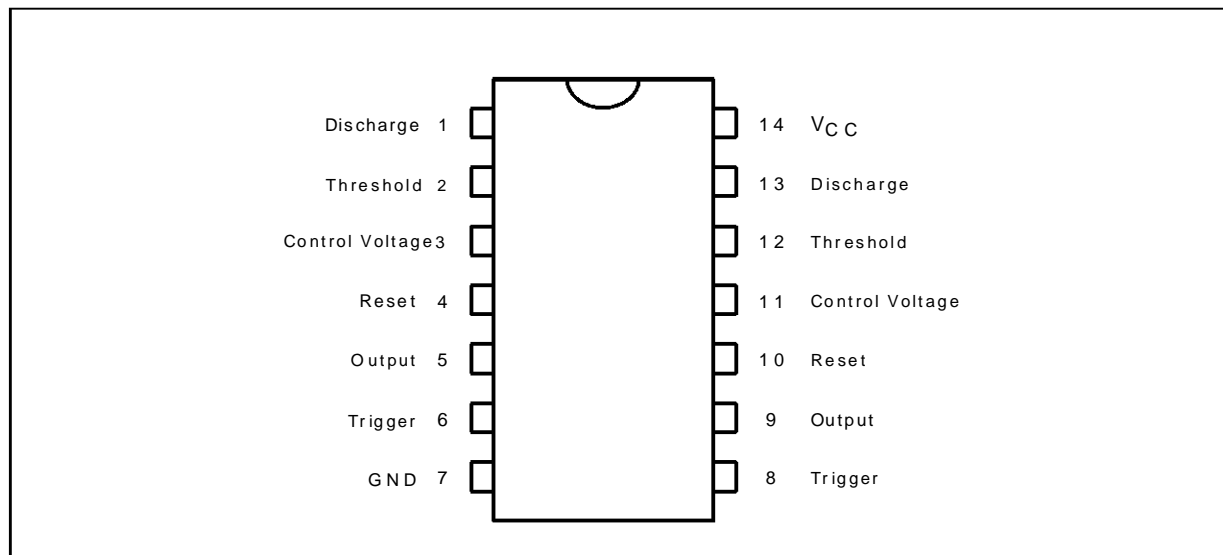

556-01.EPS

NE556/SA556/SE556

BLOCK DIAGRAM

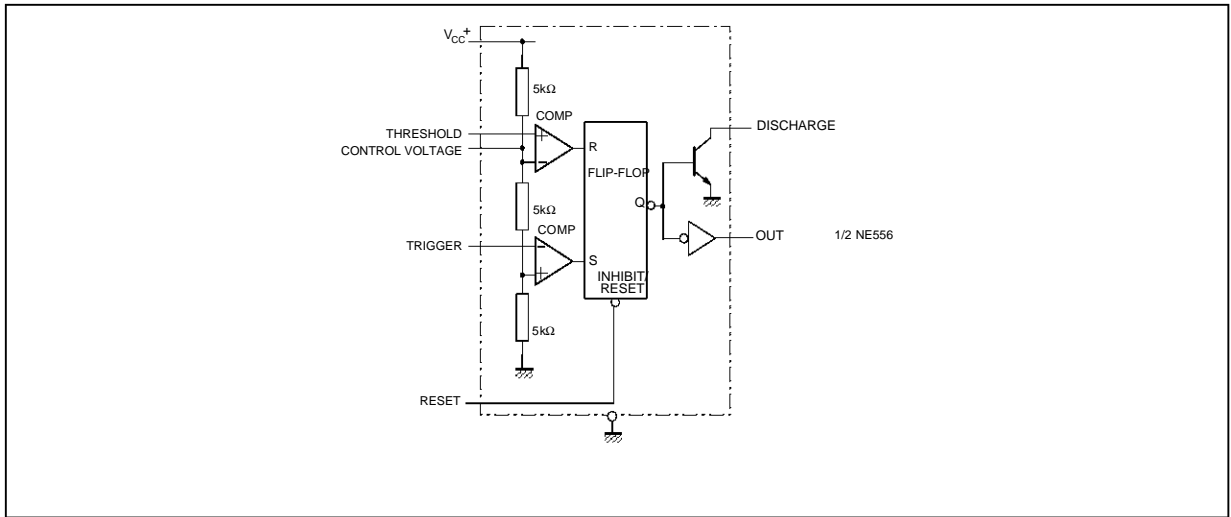

SCHEMATIC DIAGRAM

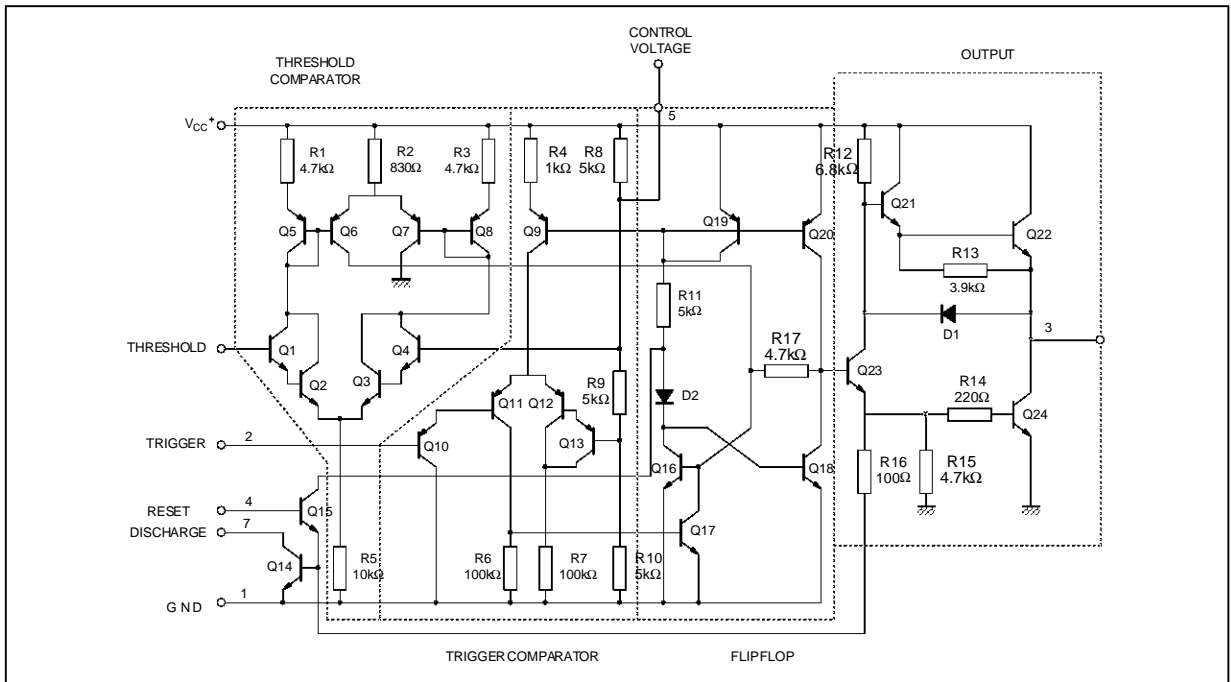

ABSOLUTE MAXIMUM RATINGS

Symbol	Parameter	Value	Unit
V _{CC}	Supply Voltage	for SE556 18 for NE556 16	V
T _{oper}	Operating Free Air Temperature Range	for NE556 0 to 70 for SA556 -40 to 105 for SE556 -55 to 125	°C
T _j	Junction Temperature	150	°C

OPERATING CONDITIONS

Symbol	Parameter	SE556	NE556 - SA556	Unit
V_{CC}	Supply Voltage	4.5 to 18	4.5 to 16	V
V_{th} , V_{trig} , V_{cl} , V_{reset}	Maximum Input Voltage	V_{CC}	V_{CC}	V

556-03.TBL

ELECTRICAL CHARACTERISTICS

 $T_{amb} = +25^{\circ}\text{C}$, $V_{CC} = +5\text{V}$ to $+15\text{V}$ (unless otherwise specified)

Symbol	Parameter	SE556			NE556 - SA556			Unit
		Min.	Typ.	Max.	Min.	Typ.	Max.	
I_{CC}	Supply Current ($R_L \infty$) - (note 1) - (2 timers)							mA
	Low State $V_{CC} = +5\text{V}$		6	10		6	12	
	High State $V_{CC} = +15\text{V}$		20	24		20	30	
	Timing Error (monostable) ($R_A = 2\text{k}$ to $100\text{k}\Omega$, $C = 0.1\mu\text{F}$)							% ppm/ $^{\circ}\text{C}$ %/V
	Initial Accuracy - (note 2)		0.5	2		1	3	
	Drift with Temperature Drift with Supply Voltage		30 0.05	100 0.2		50 0.1	3 0.5	
	Timing Error (astable) ($R_A, R_B = 1\text{k}\Omega$ to $100\text{k}\Omega$, $C = 0.1\mu\text{F}$, $V_{CC} = +15\text{V}$)							% ppm/ $^{\circ}\text{C}$ %/V
	Initial Accuracy - (note 2)		1.5			2.25		
	Drift with Temperature Drift with Supply Voltage		90 0.15			150 0.3		
V_{CL}	Control Voltage level							V
	$V_{CC} = +15\text{V}$ $V_{CC} = +5\text{V}$	9.6 2.9	10 3.33	10.4 3.8	9 2.6	10 3.33	11 4	
V_{th}	Threshold Voltage							V
	$V_{CC} = +15\text{V}$ $V_{CC} = +5\text{V}$	9.4 2.7	10 3.33	10.6 4	8.8 2.4	10 3.33	11.2 4.2	
I_{th}	Threshold Current - (note 3)		0.1	0.25		0.1	0.25	μA
V_{trig}	Trigger Voltage							V
	$V_{CC} = +15\text{V}$ $V_{CC} = +5\text{V}$	4.8 1.45	5 1.67	5.2 1.9	4.5 1.1	5 1.67	5.6 2.2	
I_{trig}	Trigger Current ($V_{trig} = 0\text{V}$)		0.5	0.9		0.5	2.0	μA
V_{reset}	Reset Voltage - (note 4)	0.4	0.7	1	0.4	0.7	1	V
I_{reset}	Reset Current							mA
	$V_{reset} = +0.4\text{V}$ $V_{reset} = 0\text{V}$		0.1 0.4	0.4 1		0.1 0.4	0.4 1.5	
V_{OL}	Low Level Output Voltage							V
	$V_{CC} = +15\text{V}$, $I_{O(sink)} = 10\text{mA}$		0.1	0.15		0.1	0.25	
	$I_{O(sink)} = 50\text{mA}$		0.4	0.5		0.4	0.75	
	$I_{O(sink)} = 100\text{mA}$		2	2.2		2	2.5	
	$I_{O(sink)} = 200\text{mA}$		2.5			2.5		
	$V_{CC} = +5\text{V}$, $I_{O(sink)} = 8\text{mA}$		0.1	0.25		0.3	0.4	
$I_{O(sink)} = 5\text{mA}$		0.05	0.2		0.25	0.35		
V_{OH}	High Level Output Voltage							V
	$V_{CC} = +15\text{V}$, $I_{O(source)} = 200\text{mA}$		13	12.5		12.5		
	$I_{O(source)} = 100\text{mA}$		13.3		12.75	13.3		
	$V_{CC} = +5\text{V}$, $I_{O(source)} = 100\text{mA}$	3	3.3		2.75	3.3		

556-4.TBL

- Notes :
- Supply current when output is high is typically 1mA less.
 - Tested at $V_{CC} = +5\text{V}$ and $V_{CC} = +15\text{V}$.
 - This will determine the maximum value of $R_A + R_B$ for +15V operation the max total is $R = 20\text{M}\Omega$ and for 5V operation, the max total $R = 3.5\text{M}\Omega$.
 - Specified with trigger input high.

ELECTRICAL CHARACTERISTICS (continued)

Symbol	Parameter	SE556			NE556 - SA556			Unit
		Min.	Typ.	Max.	Min.	Typ.	Max.	
$I_{dis(off)}$	Discharge Pin Leakage Current (output high) ($V_{dis} = 10V$)		20	100		20	100	nA
$V_{dis(sat)}$	Discharge pin Saturation Voltage (output low) - (note 5) $V_{CC} = +15V, I_{dis} = 15mA$ $V_{CC} = +5V, I_{dis} = 4.5mA$		180 80	480 200		180 80	480 200	mV
t_r t_f	Output Rise Time Output Fall Time		100 100	200 200		100 100	300 300	ns
t_{off}	Turn off Time - (note 6) ($V_{reset} = V_{CC}$)		0.5			0.5		μs

- Notes :**
- No protection against excessive Pin 7 current is necessary, providing the package dissipation rating will not be exceeded.
 - Time measured from a positive going input pulse from 0 to $0.8 \times V_{CC}$ into the threshold to the drop from high to low of the output trigger is tied to threshold.

Figure 1 : Minimum Pulse Width Required for Trigering

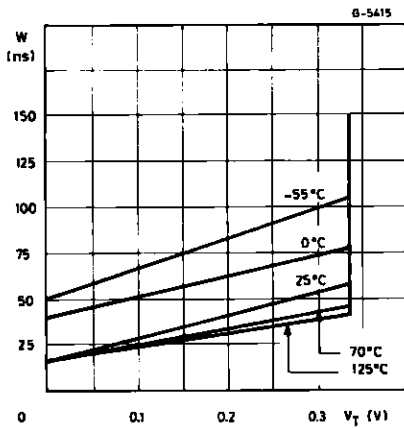

Figure 2 : Supply Current versus Supply Voltage

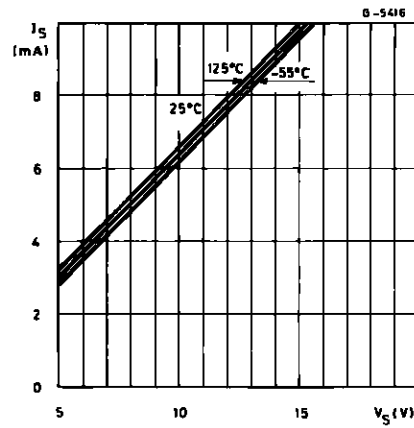

Figure 3 : Delay Time versus Temperature

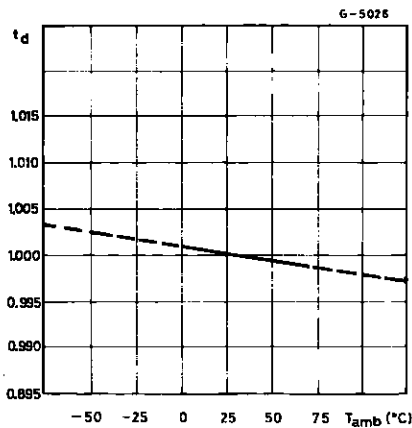

Figure 4 : Low Output Voltage versus Output Sink Current

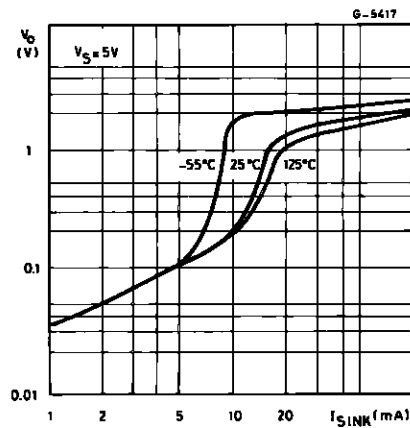
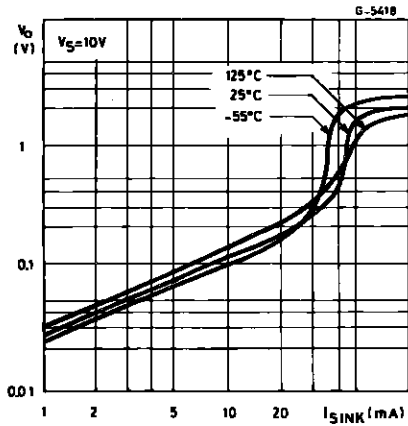
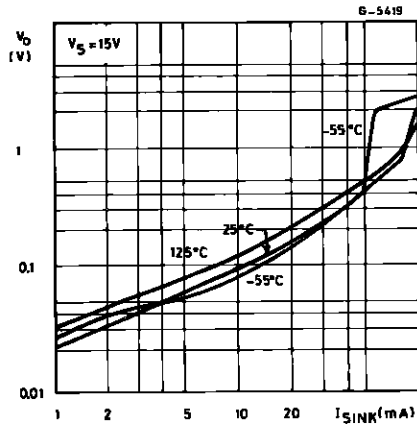

Figure 5 : Low Output Voltage versus Output Sink Current



556-08.EPS

Figure 6 : Low Output Voltage versus Output Sink Current



556-09.EPS

Figure 7 : High Output Voltage Drop versus Output

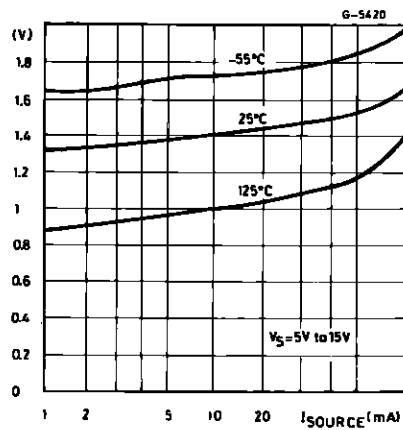

556-10.EPS

Figure 8 : Delay Time versus Supply Voltage

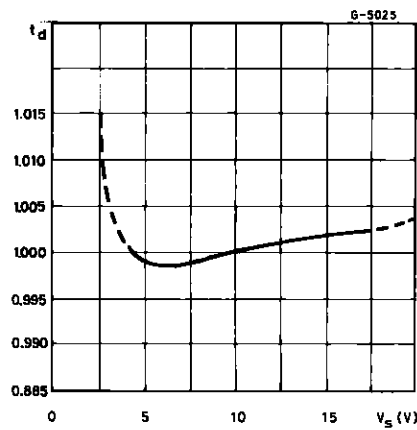

556-11.EPS

Figure 9 : Propagation Delay versus Voltage Level of Trigger Value

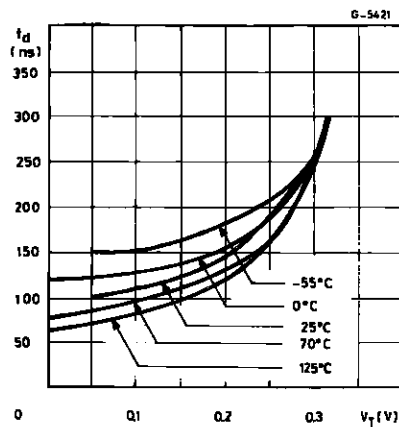

556-12.EPS

TYPICAL APPLICATION

50 % DUTY CYCLE OSCILLATOR

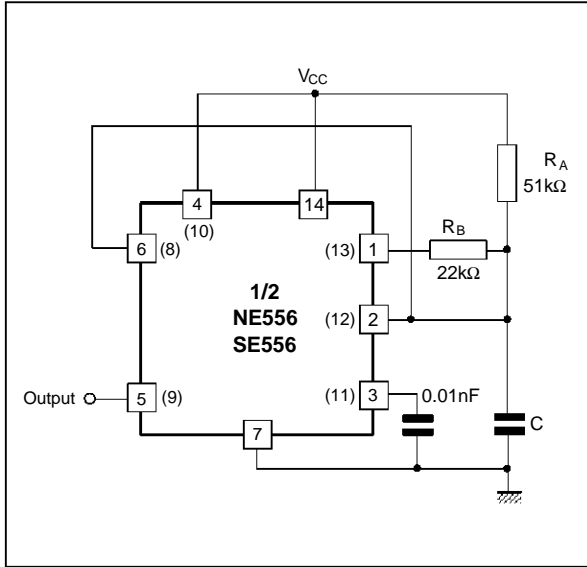

PULSE WIDTH MODULATOR

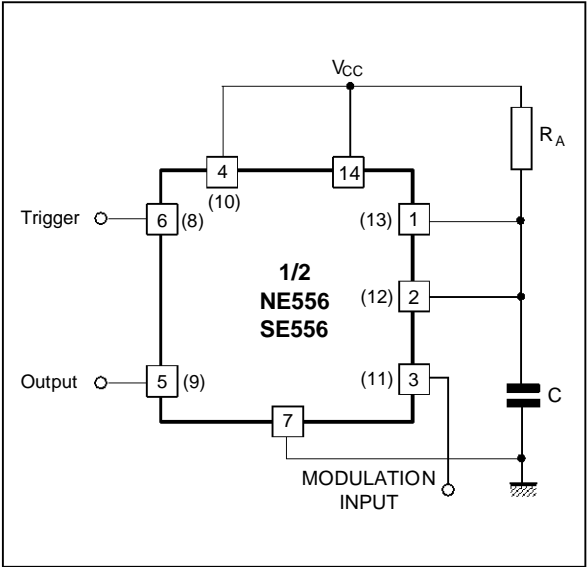

$t_1 = 0.693 R_A \cdot C$

$t_2 = [(R_A R_B) / (R_A + R_B)] \text{CLn} \left[\frac{R_B \pm 2R_A}{2R_B \pm R_A} \right]$

$f = \frac{1}{t_1 + t_2} \quad R_B < \frac{1}{2} R_A \quad t_i$

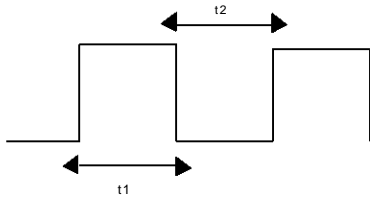

TONE BURST GENERATOR

For a tone burst generator the first timer is used as a monostable and determines the tone duration when triggered by a positive pulse at pin 6. The second timer is enabled by the high output of the monostable. It is connected as an astable and determines the frequency of the tone.

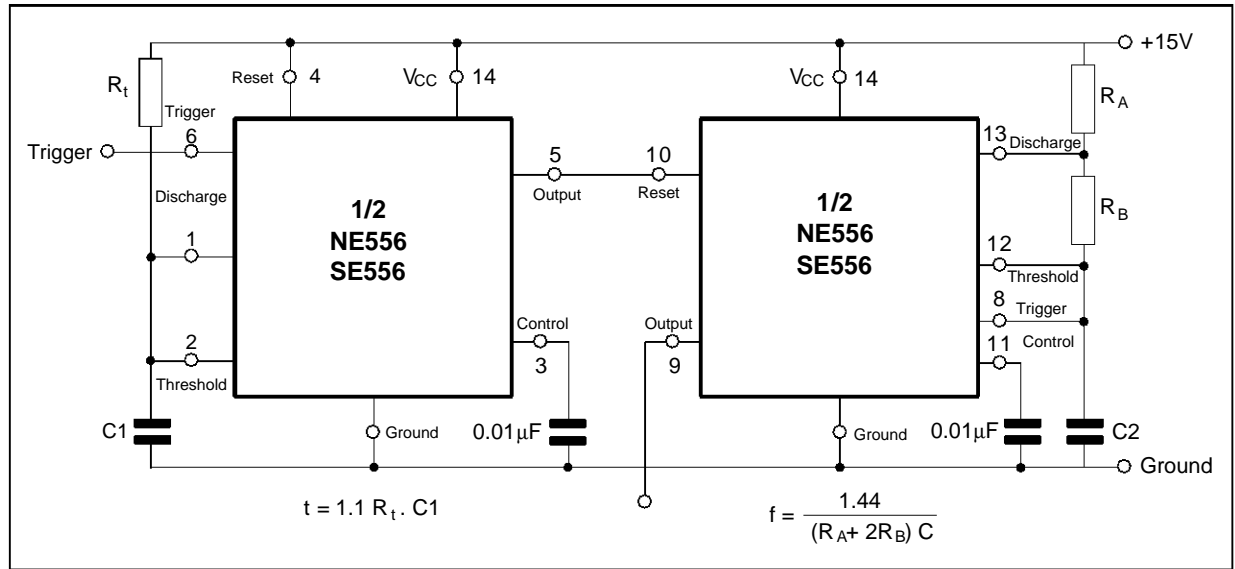

MONOSTABLE OPERATION

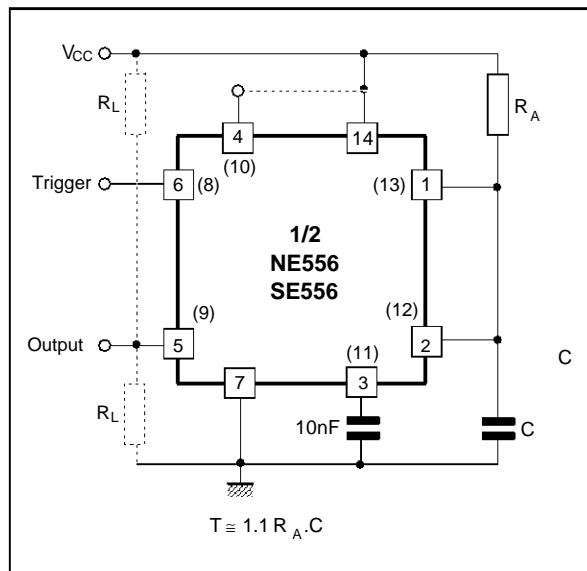

ASTABLE OPERATION

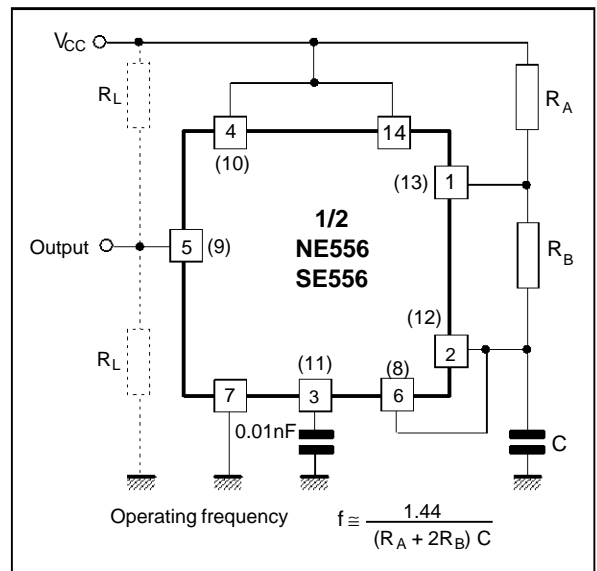

$t_1 = 0.693 (R_A + R_B) C$ Output High
 $t_2 = 0.693 R_B C$ Output low

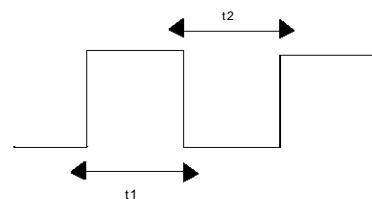

NE556/SA556/SE556

PACKAGE MECHANICAL DATA
14 PINS - PLASTIC DIP OR CERDIP

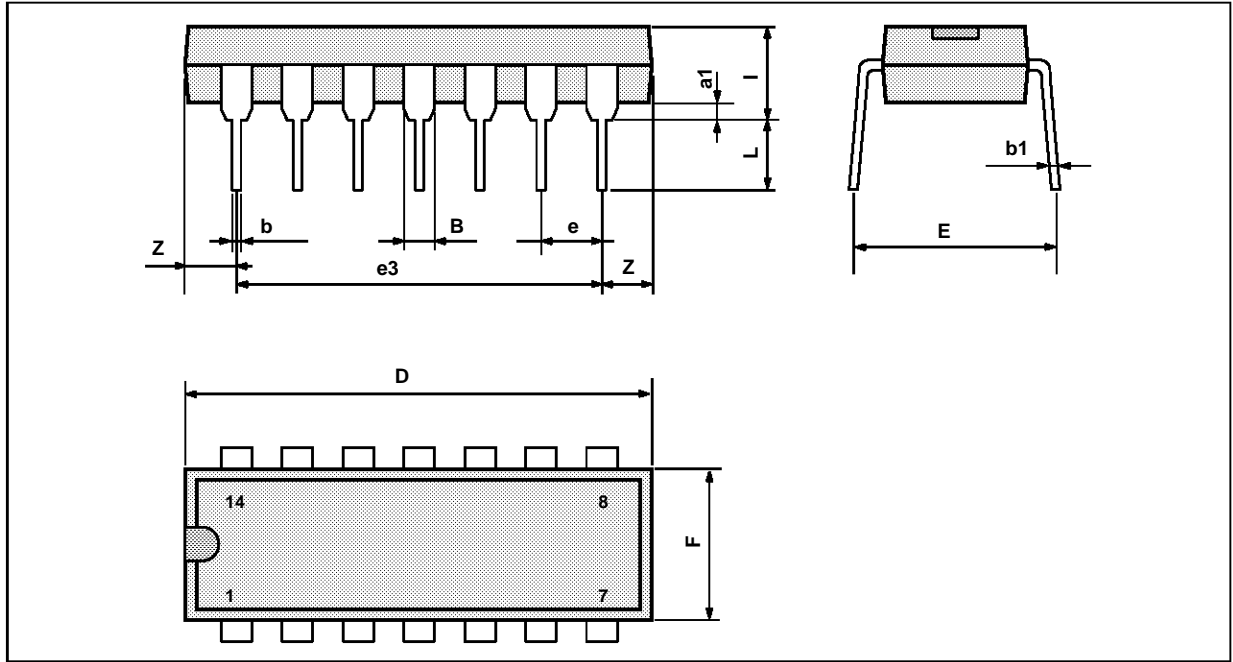

PM-DIP14LEPS

Dimensions	Millimeters			Inches		
	Min.	Typ.	Max.	Min.	Typ.	Max.
a1	0.51			0.020		
B	1.39		1.65	0.055		0.065
b		0.5			0.020	
b1		0.25			0.010	
D			20			0.787
E		8.5			0.335	
e		2.54			0.100	
e3		15.24			0.600	
F			7.1			0.280
i			5.1			0.201
L		3.3			0.130	
Z	1.27		2.54	0.050		0.100

DIP14.TEL

PACKAGE MECHANICAL DATA
14 PINS - PLASTIC MICROPACKAGE (SO)

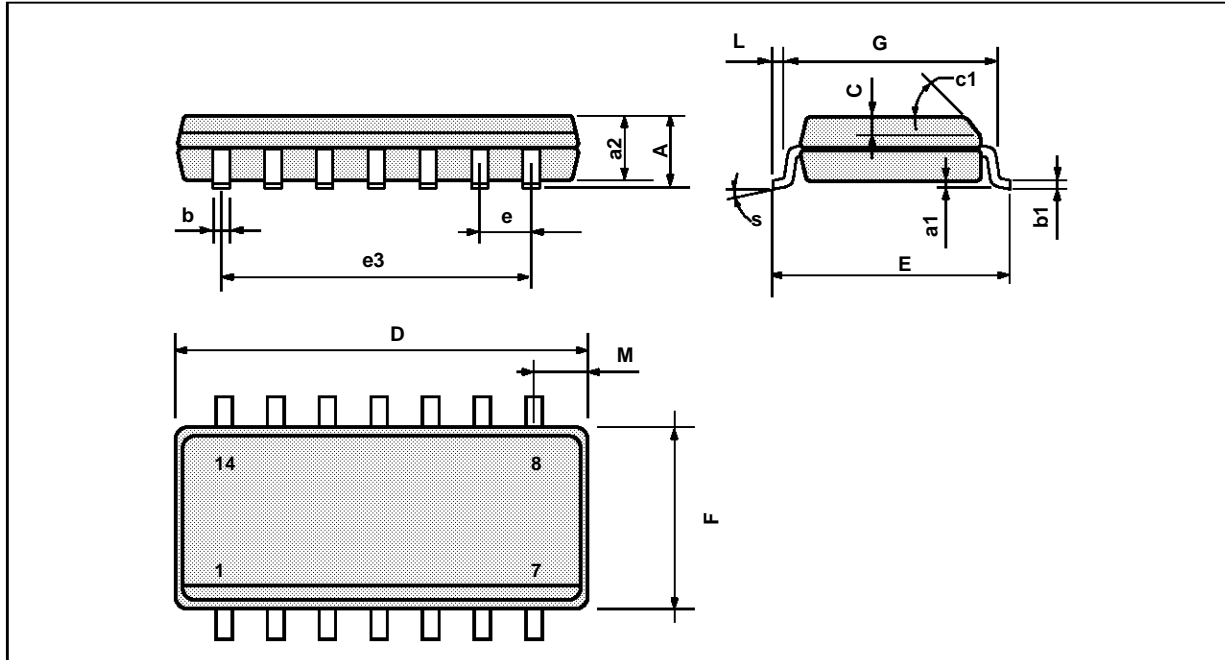

PM-SO14.EPS

Dimensions	Millimeters			Inches		
	Min.	Typ.	Max.	Min.	Typ.	Max.
A			1.75			0.069
a1	0.1		0.2	0.004		0.008
a2			1.6			0.063
b	0.35		0.46	0.014		0.018
b1	0.19		0.25	0.007		0.010
C		0.5			0.020	
c1	45° (typ.)					
D	8.55		8.75	0.336		0.334
E	5.8		6.2	0.228		0.244
e		1.27			0.050	
e3		7.62			0.300	
F	3.8		4.0	0.150		0.157
G	4.6		5.3	0.181		0.208
L	0.5		1.27	0.020		0.050
M			0.68			0.027
S	8° (max.)					

SO14.TBL

Information furnished is believed to be accurate and reliable. However, SGS-THOMSON Microelectronics assumes no responsibility for the consequences of use of such information nor for any infringement of patents or other rights of third parties which may result from its use. No licence is granted by implication or otherwise under any patent or patent rights of SGS-THOMSON Microelectronics. Specifications mentioned in this publication are subject to change without notice. This publication supersedes and replaces all information previously supplied. SGS-THOMSON Microelectronics products are not authorized for use as critical components in life support devices or systems without express written approval of SGS-THOMSON Microelectronics.

© 1994 SGS-THOMSON Microelectronics - All Rights Reserved

SGS-THOMSON Microelectronics GROUP OF COMPANIES

Australia - Brazil - France - Germany - Hong Kong - Italy - Japan - Korea - Malaysia - Malta - Morocco - The Netherlands
Singapore - Spain - Sweden - Switzerland - Taiwan - Thailand - United Kingdom - U.S.A.

ORDER CODE :