

REGULATING PULSE WIDTH MODULATORS

- COMPLETE PWM POWER CONTROL CIRCUITRY
- UNCOMMITTED OUTPUTS FOR SINGLE-ENDED OR PUSH PULL APPLICATIONS
- LOW STANDBY CURRENT 8mA TYPICAL
- OPERATION UP TO 300KHz
- 1% MAXIMUM TEMPERATURE VARIATION OF REFERENCE VOLTAGE

DESCRIPTION

The SG2524, and SG3524 incorporate on a single monolithic chip all the function required for the construction of regulating power supplies inverters or switching regulators. They can also be used as the control element for high power-output applications. The SG3524 family was designed for switching regulators of either polarity, transformer-coupled dc-to-dc converters, transformerless voltage doublers and polarity converter applications employing fixed-frequency, pulse-width modulation techniques. The dual alternating outputs allows either single-ended or push-pull appli-

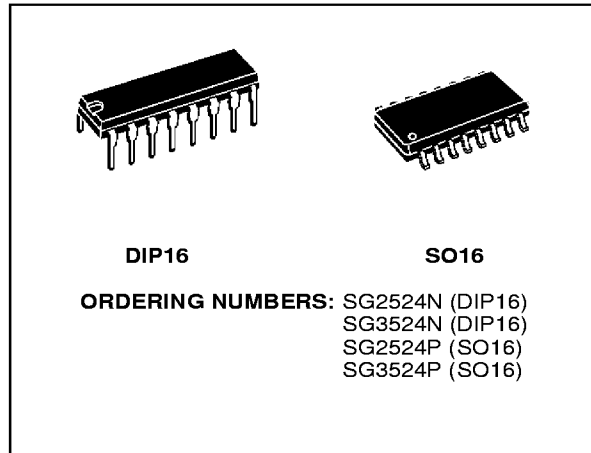

cations. Each device includes an on-ship reference, error amplifier, programmable oscillator, pulse-steering flip flop, two uncommitted output transistors, a high-gain comparator, and current-limiting and shut-down circuitry.

BLOCK DIAGRAM

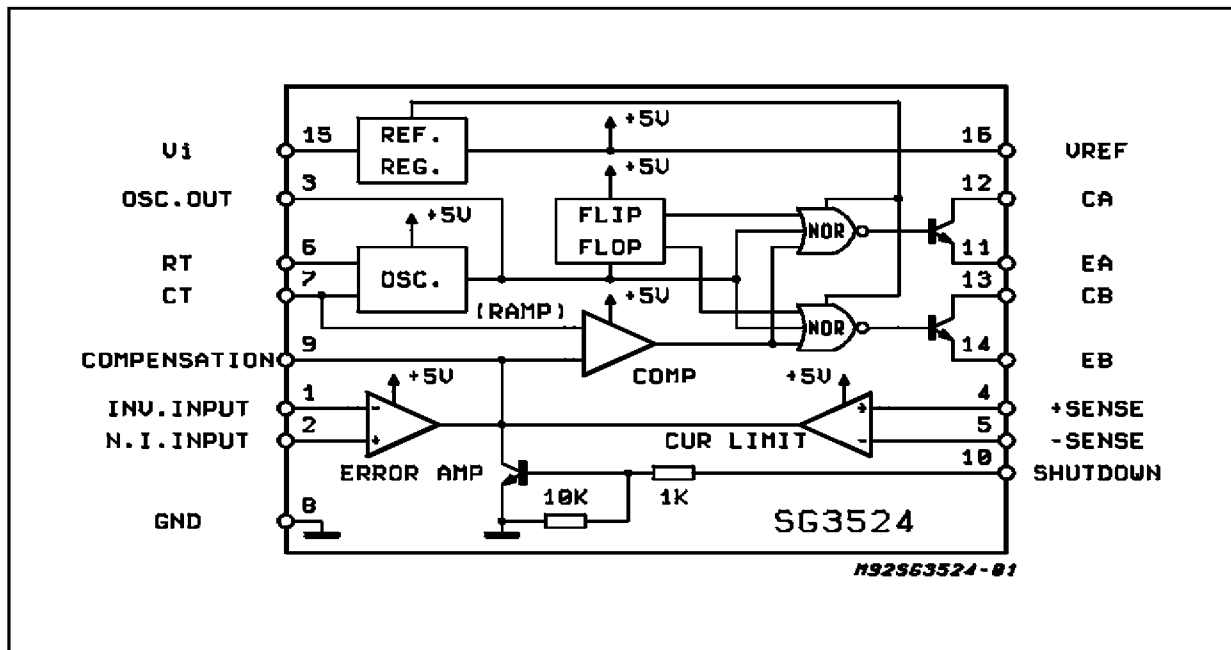

ABSOLUTE MAXIMUM RATINGS

Symbol	Parameter	Value	Unit
V_{IN}	Supply Voltage	40	V
I_C	Collector Output Current	100	mA
I_R	Reference Output Current	50	mA
I_T	Current Through C_T Terminal	- 5	mA
P_{tot}	Total Power Dissipation at $T_{amb} = 70^\circ\text{C}$	1000	mW
T_{stg}	Storage Temperature Range	- 65 to 150	$^\circ\text{C}$
T_{op}	Operating Ambient Temperature Range: SG2524 SG3524	- 25 to 85 0 to 70	$^\circ\text{C}$ $^\circ\text{C}$

PIN CONNECTION (Top view)

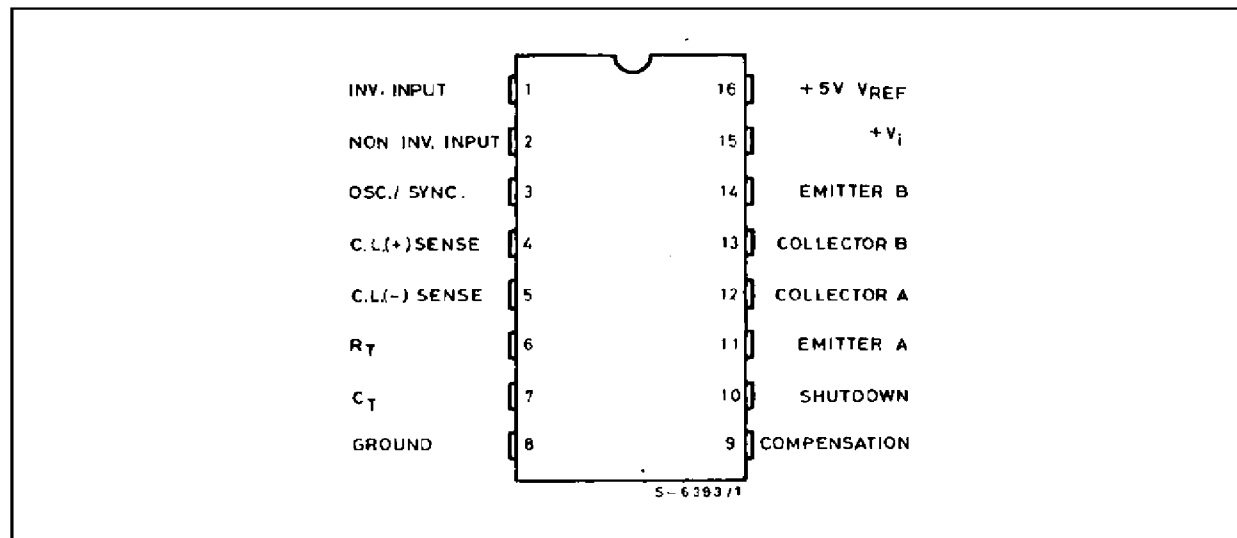

THERMAL DATA

Symbol	Parameter		DIP16	SO16	Unit
$R_{th\ j-amb}$	Thermal Resistance Junction-ambient	Max.	80	-	$^\circ\text{C}/\text{W}$
$R_{th\ j-alumina}$	Thermal Resistance Junction-alumina (*)	Max.	-	50	$^\circ\text{C}/\text{W}$

(*) Thermal resistance junction-alumina with the device soldered on the middle of an alumina supporting substrate measuring 15 x 20mm; 0.65mm thickness with infinite heatsink.

ELECTRICAL CHARACTERISTICS (unless otherwise stated, these specifications apply for $T_j = -25$ to $+85^\circ\text{C}$ for the SG2524, and 0 to 70°C for the SG3524, $V_{IN} = 20\text{V}$, and $f = 20\text{KHz}$).

Symbol	Parameter	Test Condition	SG2524			SG3524			Unit
			Min.	Typ.	Max.	Min.	Typ.	Max.	
REFERENCE SECTION									
V_{REF}	Output Voltage		4.8	5	5.2	4.6	5	5.4	V
ΔV_{REF}	Line Regulation	$V_{IN} = 8$ to 40V		10	20		10	30	mV
ΔV_{REF}	Load Regulation	$I_L = 0$ to 20mA		20	50		20	50	mV
	Ripple Rejection	$f = 120\text{Hz}$, $T_j = 25^\circ\text{C}$		66			66		dB
	Short Circuit Current Limit	$V_{REF} = 0$, $T_j = 25^\circ\text{C}$		100			100		mA
$\Delta V_{REF}/\Delta T$	Temperature Stability	Over Operating Temperature range		0.3	1		0.3	1	%
ΔV_{REF}	Long Term Stability	$T_j = 125^\circ\text{C}$, $t = 1000\text{Hrs}$		20			20		mV
OSCILLATOR SECTION									
f_{MAX}	Maximum Frequency	$C_T = 0.001\mu\text{F}$, $R_T = 2\text{K}\Omega$		300			300		KHz
	Initial Accuracy	R_T and C_T Constant		5			5		%
	Voltage Stability	$V_{IN} = 8$ to 40V , $T_j = 25^\circ\text{C}$			1			1	%
$\Delta f/\Delta T$	Temperature Stability	Over Operating Temperature Range			2			2	%
	Output Amplitude	Pin 3, $T_j = 25^\circ\text{C}$		3.5			3.5		V
	Output Pulse Width	$C_T = 0.01\mu\text{F}$, $T_j = 25^\circ\text{C}$		0.5			0.5		μs
ERROR AMPLIFIER SECTION									
V_{OS}	Input Offset Voltage	$V_{CM} = 2.5\text{V}$		0.5	5		2	10	mV
I_b	Input Bias Current			2	10		2	10	μA
G_V	Open Loop Voltage Gain		72	80		60	80		dB
CMV	Common Mode Voltage	$T_j = 25^\circ\text{C}$	1.8		3.4	1.8		3.4	V
CMR	Common Mode Rejection	$T_j = 25^\circ\text{C}$		70			70		dB
B	Small Signal Bandwidth	$A_V = 0\text{dB}$, $T_j = 25^\circ\text{C}$		3			3		MHz
V_O	Output Voltage	$T_j = 25^\circ\text{C}$	0.5		3.8	0.5		3.8	V
COMPARATOR SECTION									
	Duty-cycle	% Each Output On	0		45	0		45	%
V_{IT}	Input Threshold	Zero Duty-cycle		1			1		V
		Maximum Duty-cycle		3.5			3.5		V
I_b	Input Bias Current			1			1		μA
CURRENT LIMITING SECTION									
	Sense Voltage	Pin 9 = 2V with Error Amp. Set for Max. Out. $T_j = 25^\circ\text{C}$	190	200	210	180	200	220	mV
	Sense Voltage T.C.			0.2			0.2		$\text{mV}/^\circ\text{C}$
CMV	Common Mode Voltage		-1		1	-1		1	
OUTPUT SECTION (each output)									
	Collector-emitter Voltage		40			40			V
	Collector Leakage Curr.	$V_{CE} = 40\text{V}$		0.1	50		0.1	50	μA
	Saturation Voltage	$I_C = 50\text{mA}$		1	2		1	2	V
	Emitter Output Voltage	$V_{IN} = 20\text{V}$	17	18		17	18		V
t_r	Rise Time	$R_C = 2\text{K}\Omega$, $T_j = 25^\circ\text{C}$		0.2			0.2		μs
t_f	Fall Time	$R_C = 2\text{K}\Omega$, $T_j = 25^\circ\text{C}$		0.1			0.1		μs
I_q (*)	Total Standby Current	$V_{IN} = 40\text{V}$		8	10		8	10	mA

(*) Excluding oscillator charging current, error and current limit dividers, and with outputs open.

Figure 1: Open-loop Voltage Amplification of Error Amplifier vs. Frequency

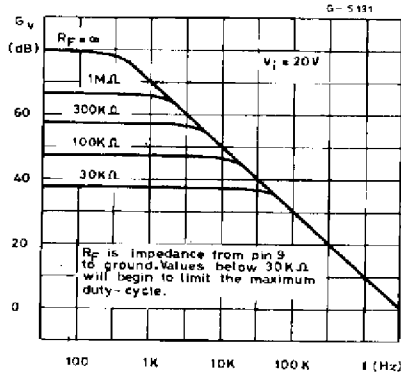

Figure 2: Oscillator Frequency vs. Timing Components

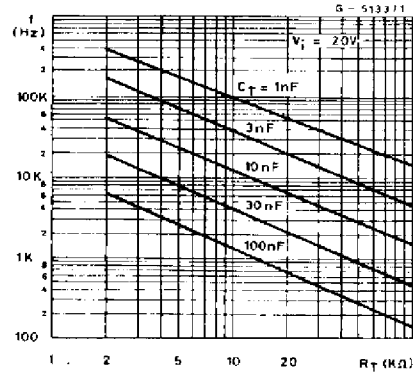

Figure 3: Output Dead Time vs. Timing Capacitance Value

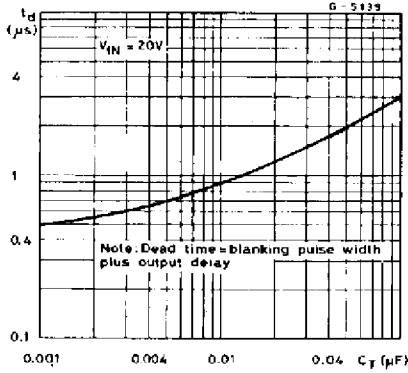

Figure 4: Output Saturation Voltage vs. load Current

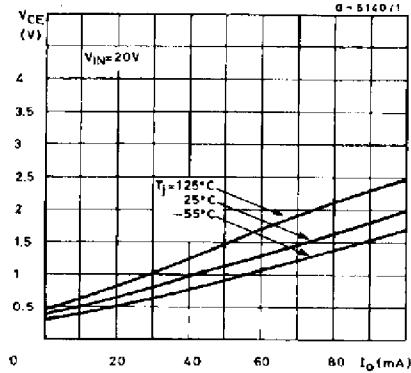
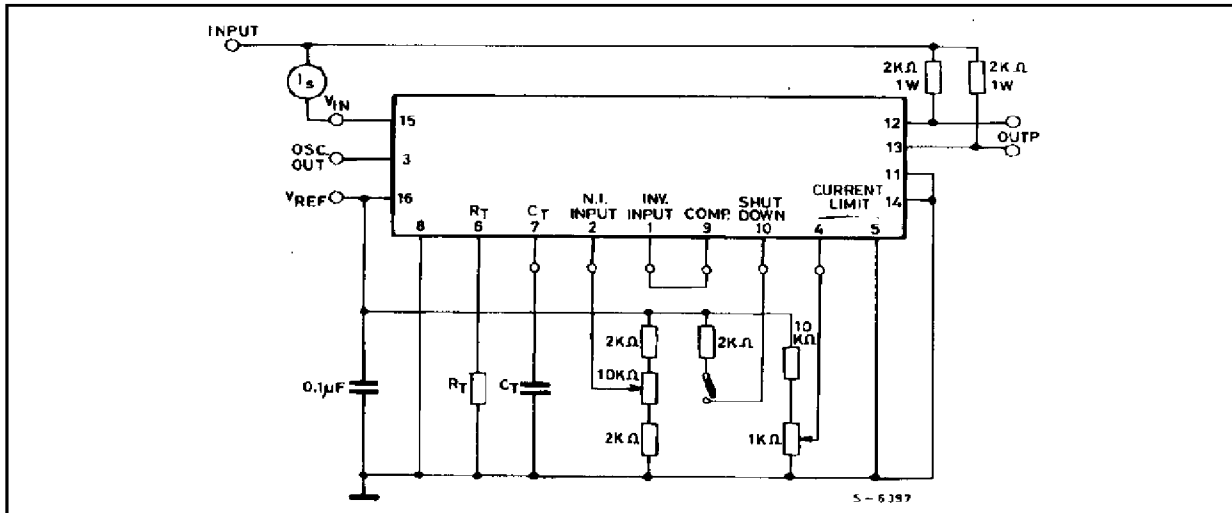

Figure 5: Open Loop Test Circuit.



PRINCIPLES OF OPERATION

The SG2524/3524 is a fixed frequency pulse-with-modulation voltage regulator control circuit. The regulator operates at a frequency that is programmed by one timing resistor (R_T) and one timing capacitor (C_T). R_T established a constant charging current for C_T. This results in a linear voltage ramp at C_T, which is fed to the comparator providing linear control of the output pulse width by the error amplifier. the SG2524/3524 contains, an on-board 5V regulator that serves as a reference as well as powering the SG2524/3524's internal control circuitry and is also useful in supplying external support functions. This reference voltage is lowered externally by a resistor divider to provide a reference within the common mode range the error amplifier or an external reference may be used. The power supply output is sensed by a second resistor divider network to generate a feedback signal to error amplifier. The amplifier output voltage is then compared to the linear voltage ramp at C_T. The resulting modulated pulse out of the high-gain comparator is then steered to the appropriate output pass transistors (Q_A or Q_B) by the pulse-steering flip-flop, which is synchronously toggled by the oscillator output. The oscillator output pulse also serves as a blanking pulse to assure both output are never on simultaneously during the transition times. The width of the blanking pulse is controlled by the value of C_T. The outputs may be applied in a push-pull configuration in which their frequency is half that of the base oscillator, or paralleled for single-ended applications in which the frequency is equal to that of the oscillator. The output of the error amplifier shares a common input to the comparator with the current limiting at shutdown circuitry and can be overridden by signals from either of these inputs. This common point is also available externally and may be employed to control the gain of, or to compensate, the error amplifier, or to provide additional control to the regulator.

RECOMMENDED OPERATING CONDITIONS

Supply voltage V _{IN}	8 to 40V
Reference Output Current	0 to 20mA
Current trough C _T Terminal	- 0.03 to -2mA
Timing Resistor, R _T	1.8 to 100KΩ
Timing Capacitor, C _T	0.001 to 0.1μF

TYPICAL APPLICATIONS DATA

OSCILLATOR

The oscillator controls the frequency of the

SG2524 and is programmed by R_T and C_T according to the approximate formula:

$$f = \frac{1.18}{R_T C_T}$$

where:

R_T is in KΩ

C_T is in μF

f is in KHz

Practical values of C_T fall between 0.001 and 0.1μF. Practical values of R_T fall between 1.8 and 100KΩ. This results in a frequency range typically from 120Hz to 500KHz.

BLANKING

The output pulse of oscillator is used as a blanking pulse at the output. This pulse width is controlled by the value of C_T. If small values of C_T are required for frequency control, the oscillator output pulse width may still be increased by applying a shunt capacitance of up to 100pF from pin 3 to ground. If still greater dead-time is required, it should be accomplished by limiting the maximum duty cycle by clamping the output of the error amplifier. This can easily be done with the circuit below:

Figure 6.

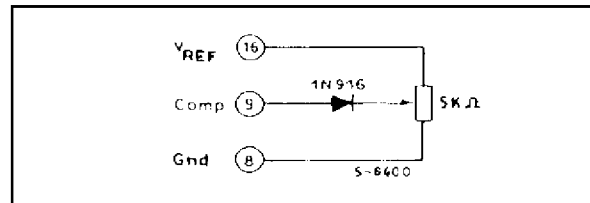

SYNCHRONOUS OPERATION

When an external clock is desired, a clock pulse of approximately 3V can be applied directly to the oscillator output terminal. The impedance to ground at this point is approximately 2KΩ. In this configuration R_T C_T must be selected for a clock period slightly greater than that the external clock.

If two more SG2524 regulators are to be operated synchronously, all oscillator output terminals should be tied together, all C_T terminals connected to a single timing capacitor, and timing resistor connected to a single R_T terminal. The other R_T terminals can be left open or shorted to V_{REF}. Minimum lead lengths should be used between the C_T terminals.

Figure 7: Flyback Converter Circuit.

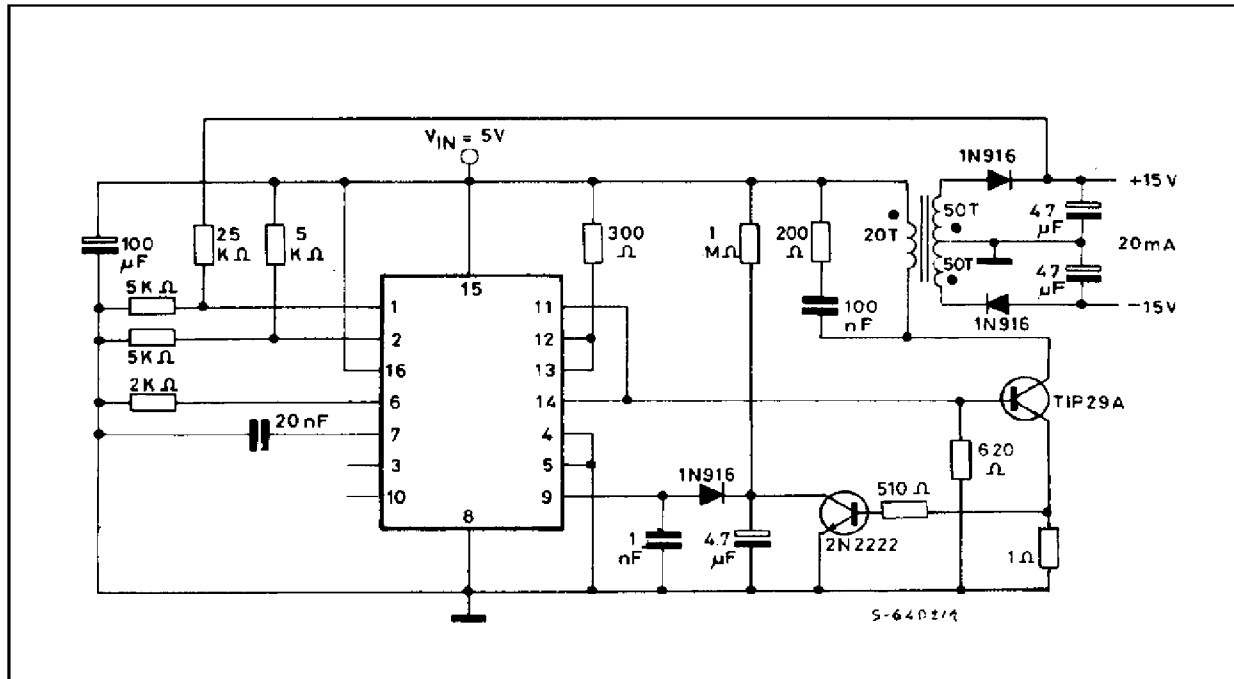
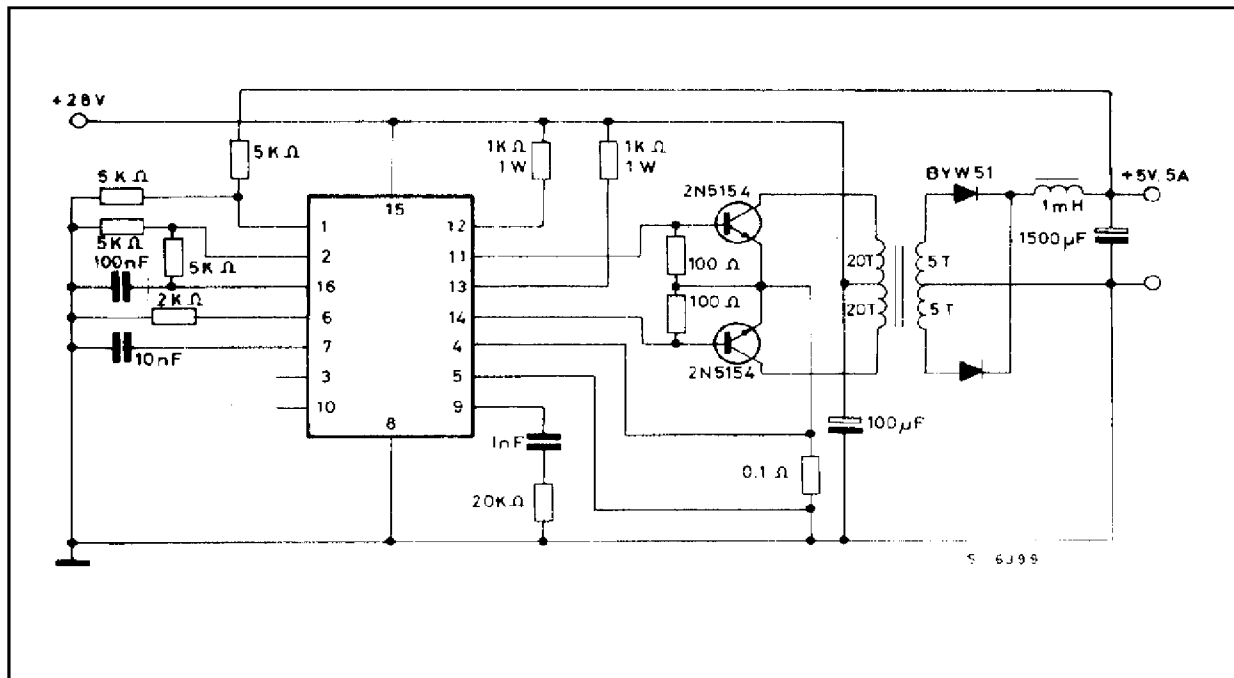
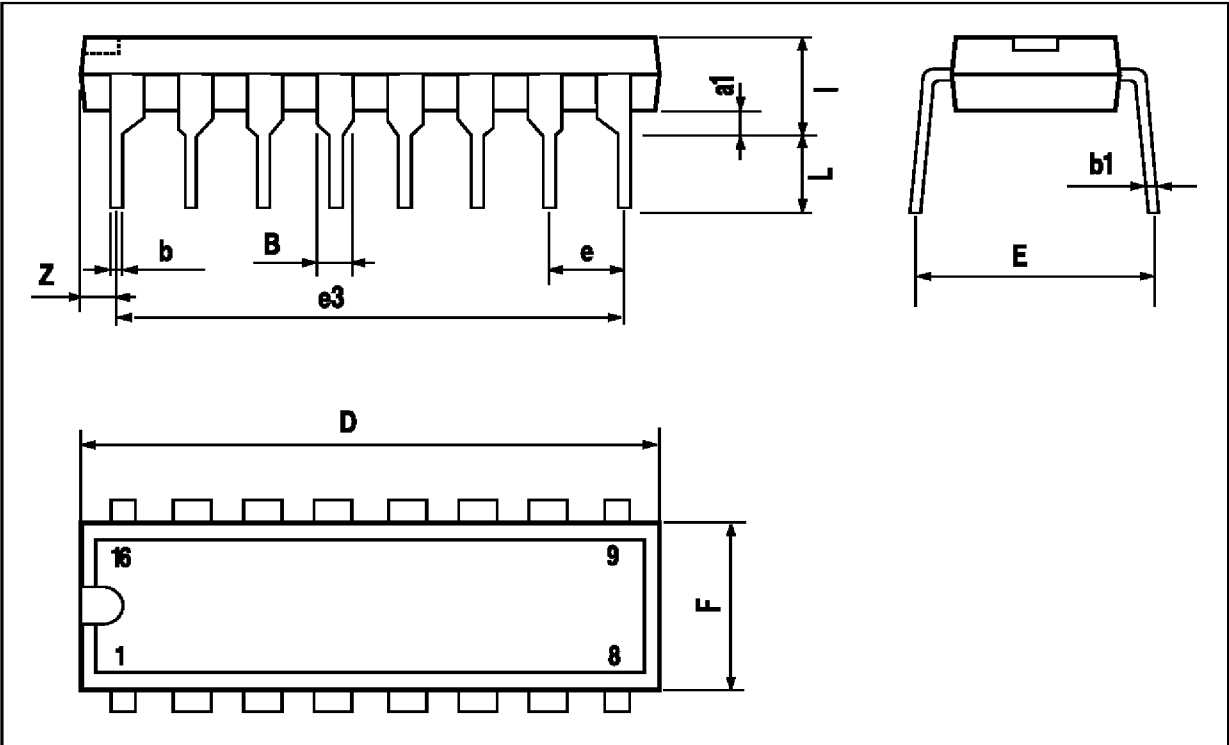

Figure 8: PUSH-PULL Transformer-coupled circuit.



DIP16 PACKAGE MECHANICAL DATA

DIM.	mm			inch		
	MIN.	TYP.	MAX.	MIN.	TYP.	MAX.
a1	0.51			0.020		
B	0.77		1.65	0.030		0.065
b		0.5			0.020	
b1		0.25			0.010	
D			20			0.787
E		8.5			0.335	
e		2.54			0.100	
e3		17.78			0.700	
F			7.1			0.280
l			5.1			0.201
L		3.3			0.130	
Z			1.27			0.050



SO16 NARROW PACKAGE MECHANICAL DATA

DIM.	mm			Inch		
	MIN.	TYP.	MAX.	MIN.	TYP.	MAX.
A			1.75			0.069
a1	0.1		0.25	0.004		0.009
a2			1.6			0.063
b	0.35		0.46	0.014		0.018
b1	0.19		0.25	0.007		0.010
C		0.5			0.020	
c1	45° (typ.)					
D	9.8		10	0.386		0.394
E	5.8		6.2	0.228		0.244
e		1.27			0.050	
e3		8.89			0.350	
F	3.8		4.0	0.150		0.157
L	0.4		1.27	0.150		0.050
M			0.62			0.024
S	8° (max.)					

