

**VIDEO MATRIX**

- 6 CVBS INPUTS - 3 CVBS OUTPUTS
- 4 Y/C INPUTS - 2 Y/C OUTPUTS
- 2 EXTRA Y/C INPUTS FOR EXTERNAL COMB FILTERS
- 3 Y/C ADDERS (ONE WITH EXTERNAL TRAP FILTER)
- CLAMP MODE : SYNC BOTTOM ON CVBS AND Y INPUTS, AVERAGE ON C INPUTS
- S SELECTED INPUT FORWARDED TO SOUT PIN (auto mode) OR PROGRAMMABLE (soft mode)
- BANDWIDTH : 15MHz
- CROSSTALK : 50dB min.
- STATUS REGISTER AVAILABLE THROUGH I<sup>2</sup>C BUS (S1, S2, S3, ID1-1, ID1-2)
- 2 SELECTABLE SLAVE ADDRESSES
- I<sup>2</sup>C BUS CONTROL

**DESCRIPTION**

This device is an I<sup>2</sup>C bus controlled video switch dedicated to TV applications. It handles video or chroma input signals, filtered or not, which are forwarded to selected outputs.

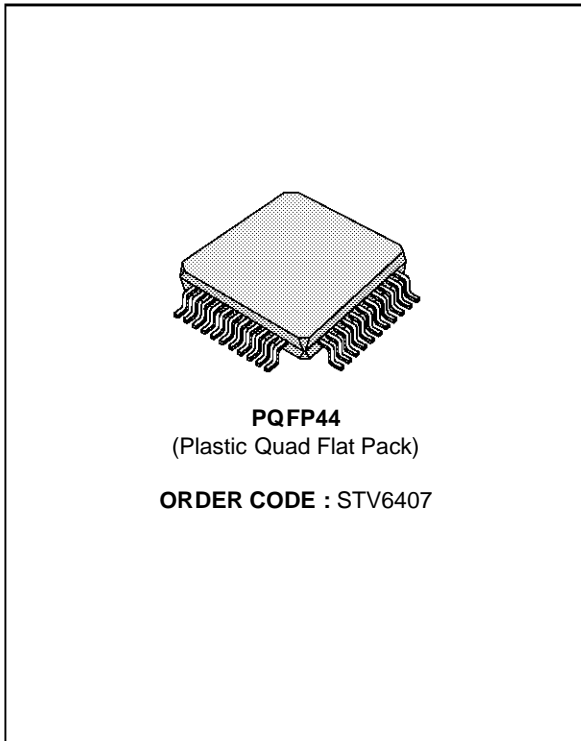

**PIN CONNECTIONS**

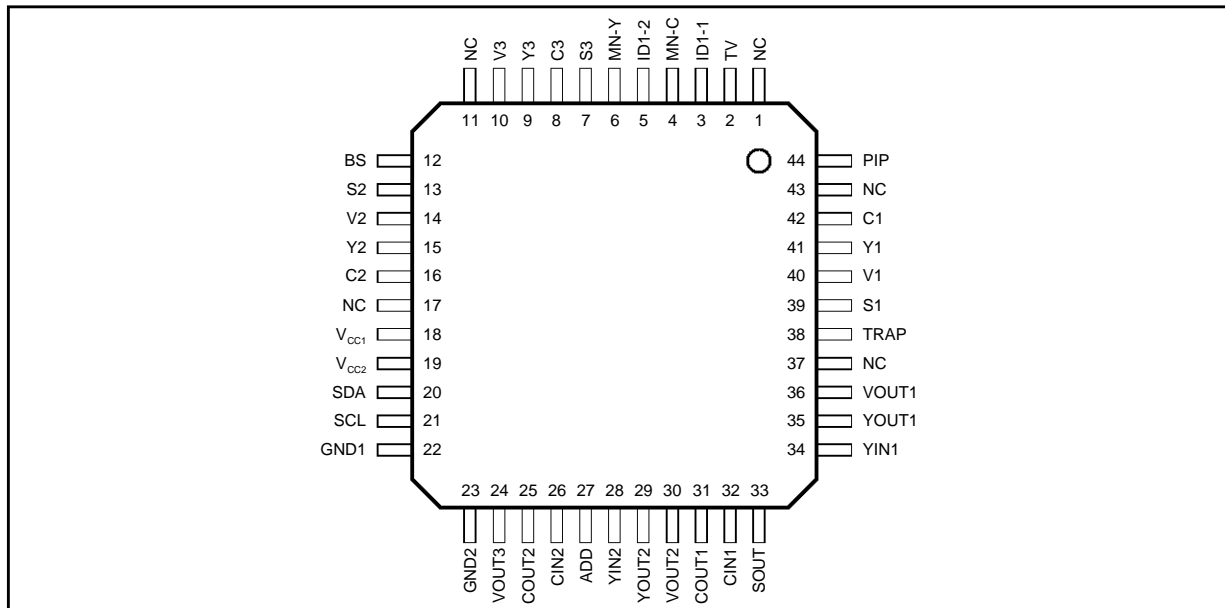

6407-01.EPS

BLOCK DIAGRAM

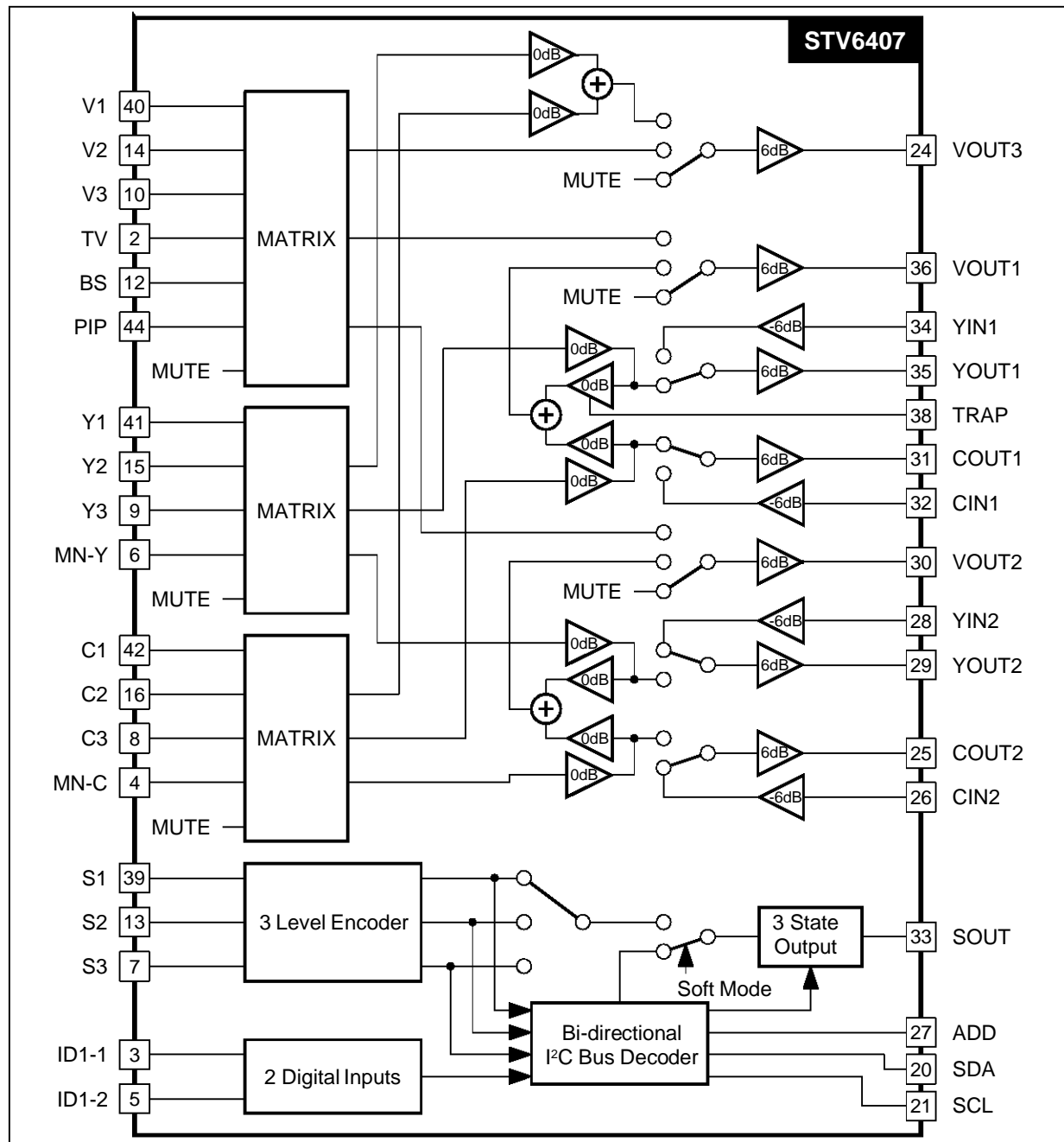

6407-02.EPS

## FUNCTIONAL DESCRIPTION

The STV6407 is basically composed of 3 sets of CVBS and Y/C inputs which can be commuted through I<sup>2</sup>C bus control to respective CVBS or Y/C outputs.

All CVBS and Y input signals are synchro bottom clamped, while C signals are average. Thanks to internal Y/C adders and amplifiers, it is possible to generate additional CVBS signals depending on the selected output group.

Every output VOUT1, VOUT2 and VOUT3 supplies a CVBS signal issued from either a CVBS input or from added Y/C signals. Thanks to an external trap filter connected to the TRAP input, the Y signal from Y matrix can be filtered before being combined to C signal from C matrix and then directed to VOUT1. YOUT1/COU1 and YOUT2/COU2 deliver Y/C signals coming from external comb filters if input is a CVBS source or from Y/C sources if Y/C sources are used.

Besides switching function, the STV6407 outputs a control signal on SOUT pin which can be related to the selected switching group or can be used to

drive other devices according to either of the 2 programming modes :

- In the former mode, SOUT supplies the encoded signal received through 3 level encoders from S1, S2 or S3 input when the corresponding switching input group (V1, Y1, C1 or V2, Y2, C2 or V3, Y3, C3) is selected and if b5 of control register is reset. If b5 = 1, SOUT is unchanged when a new input group is selected. For example, if V3, Y3, C3 is selected and then if b5 = 0, SOUT will reflect S3 input level : if S3 input voltage changes, SOUT will be automatically updated.
- In the latter mode, SOUT can be driven directly through I<sup>2</sup>C bus. This mode, called SOFT MODE (b7 = b6 = 1, b5 = b4 = b1 = b0 = 0), allows 4 different settings of SOUT : 0V, 2.5V, 5V or high impedance. SOUT can then be used to drive other interface devices or plugs (pin 8 of SCART plugs).

The status register readable through I<sup>2</sup>C bus indicates status of the two logical encoders ID1-1 and ID1-2 (bits b0 and b1) and of S1, S2 and S3 inputs (bits b2 to b7).

## ABSOLUTE MAXIMUM RATINGS

Symbol	Parameter	Value	Unit
V <sub>CC</sub>	Supply Voltage	7	V
V <sub>I</sub>	Voltage at Pin I to GND	0, V <sub>CC</sub>	V
T <sub>oper</sub>	Operating Ambient Temperature	-20, +70	°C
T <sub>stg</sub>	Storage Temperature	-20, +150	°C

6407-01.TBL

## THERMAL DATA

Symbol	Parameter	Value	Unit
R <sub>th(j-a)</sub>	Junction Ambient Thermal Resistance	85	°C/W

6407-02.TBL

## STV6407

### ELECTRICAL CHARACTERISTICS

( $V_{CC} = 5V$ ,  $T_{amb} = 25^{\circ}C$ ,  $C_{load} = 20pF$ ,  $R_{load} = 1k\Omega$ , unless otherwise specified)

Symbol	Parameter	Test Conditions	Min.	Typ.	Max.	Unit
--------	-----------	-----------------	------	------	------	------

#### SUPPLY

$V_{CC1,2}$	Supply Voltage		4.5	5	5.5	V
$I_{CC1+2}$	Supply Current		25	40	55	mA
$R_R$	Supply Voltage Rejection	$f = 1kHz$		40		dB

#### INPUTS

$V_{IN}$	Signal Amplitude (all CVBS, Y, C inputs)		1.5	1.8		$V_{PP}$
$V_{clamp}$	Clamp Level (CVBS, Y inputs)		1.1	1.35	1.6	V
$I_{clamp}$	Clamp Current (CVBS, Y inputs)	$V_{clamp} - 300mV$		0.5	2	mA
$I_{IN}$	Leakage Current (CVBS, Y inputs)	$V_{clamp} + 1V$		0.5	2	$\mu A$
$V_{DC}$	Input DC Level ( C, TRAP)		1.1	1.35	1.6	V
$R_{IN}$	Input Resistance (C inputs)		7	11	16	$k\Omega$
$R_{TRAP}$	Input Resistance (TRAP input)		0.75	1	1.25	$k\Omega$

#### VIDEO OUTPUTS

GV	Voltage Gain	$V_{IN} = 1V_{PP}$ $V_{OUT3}$ Other outputs	5.7 5.5	6.2 6	6.7 6.5	dB dB
B	Bandwidth (CVBS, Y/C adder)	$C_{load} = 20pF$ att = -1dB att = -3dB		10 15		MHz MHz
CTK	Crosstalk Between Channels	$f = 3.58MHz$ , $V_{IN} = 1V_{PP}$ Same group input/output Diff. group input/output	50 55	55 60		dB dB
$R_{OUT}$	Output Resistance			10	30	$\Omega$
$V_{sync}$	Top Level Sync (Y or CVBS)		0.5	0.7	1	V
$V_{bias}$	Output Mean Level (chroma)		1.1	1.35	1.6	V

#### SOUT OUTPUT

$S_{OL}$	SOUT Low Level	$S1, S2, S3 < 0.8V$			0.8	V
$S_{OM}$	SOUT Mid Level	$1.3V < S1, S2, S3 < 3.5V$	1.3	2.5	3.5	V
$S_{OH}$	SOUT High Level	$S1, S2, S3 > 4.5V$	4.5			V
$R_{SOUT}$	SOUT Output Impedance	(94C0), $V_{OUT} = 2.5V$ (94C4), $V_{OUT} = 0V$ (94CC), $V_{OUT} = 0V$	0.1 1 0.1	0.5 3 0.8	1 5 1.6	$k\Omega$ $k\Omega$ $k\Omega$
$R_{SOUTI}$	SOUT Output Impedance	(94C8), $V_{OUT} = 5V$	1	5		$M\Omega$

6407-03.TBL

**I<sup>2</sup>C BUS CHARACTERISTICS**

Symbol	Parameter	Test Conditions	Stand. Mode		Fast Mode		Unit
			Min.	Max.	Min.	Max.	

## SCL

V <sub>IL</sub>	Low Level Input Voltage		-0.3	1.5	-0,3	1,5	V
V <sub>IH</sub>	High Level Input Voltage		3	V <sub>CC</sub> +0.5	3	V <sub>CC</sub> +0.5	V
I <sub>LI</sub>	Input Leakage Current	V <sub>IN</sub> = 0 to V <sub>CC</sub>	-10	10	-10	10	μA
f <sub>SCL</sub>	Clock Frequency		0	100	0	400	kHz
t <sub>R</sub>	Input Rise Time	1.5V to 3V		1,000		300	ns
t <sub>F</sub>	Input Fall Time	1.5V to 3V		300		300	ns
C <sub>i</sub>	Input Capacitance			10		10	pF

## SDA

V <sub>IL</sub>	Low Level Input Voltage		-0.3	1.5	-0,3	1,5	V
V <sub>IH</sub>	High Level Input Voltage		3	V <sub>CC</sub> +0.5	3	V <sub>CC</sub> +0.5	V
I <sub>LI</sub>	Input Leakage Current	V <sub>IN</sub> = 0 to V <sub>CC</sub>	-10	10	-10	10	μA
C <sub>i</sub>	Input Capacitance			10		10	pF
t <sub>R</sub>	Input Rise Time	1.5V to 3V		1,000		300	ns
t <sub>F</sub>	Input Fall Time	1.5V to 3V		300		300	ns
V <sub>OL</sub>	Low Level Output Voltage	I <sub>OL</sub> = 3mA		0.4		0.4	V
t <sub>F</sub>	Output Fall Time	3V to 1.5V		250		250	ns
C <sub>L</sub>	Load Capacitance			400		400	pF

## TIMING

t <sub>LOW</sub>	Clock Low Period		4.7		1.3		μs
t <sub>HIGH</sub>	Clock High Period		4		0.6		μs
t <sub>SU,DAT</sub>	Data Set-up Time		250		100		ns
t <sub>HD,DAT</sub>	Data Hold Time		0	340	0	340	ns
t <sub>SU,STO</sub>	Set-up Time from Clock High to Stop		4		0.6		μs
t <sub>BUF</sub>	Start Set-up Time Following a Stop		4.7		1.3		μs
t <sub>HD,STA</sub>	Start Hold Time		4		0.6		μs
t <sub>SU,STA</sub>	Start Set-up Time Following Clock Low to High Transition		4.7		0.6		μs

6407-04.TBL

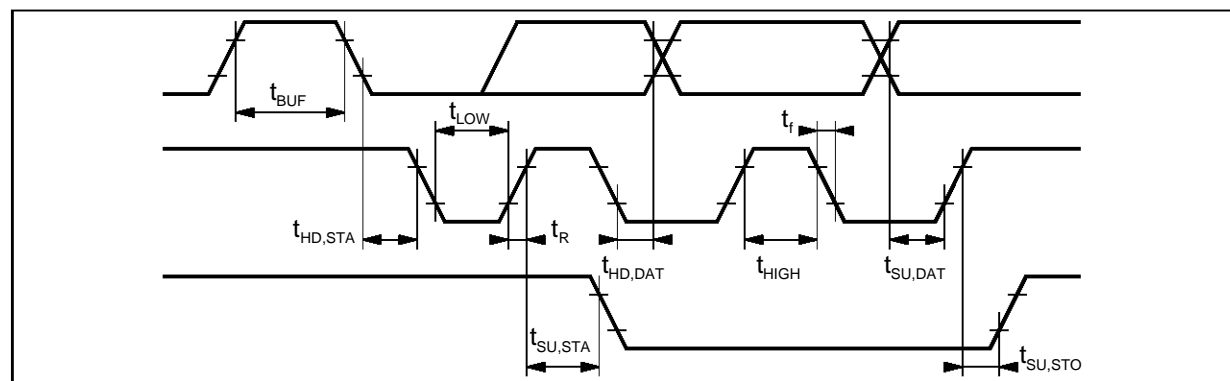
**Figure 1 : I<sup>2</sup>C Bus Timing**

6407-03.EPS

**I<sup>2</sup>C BUS SELECTION**

Data transfers follow the usual I<sup>2</sup>C format : after the start condition (S), a 7-bit slave address is sent, followed by an eighth bit which is a data direction bit (R/W). Several successive data bytes can be sent in WRITE mode (R/W = 0) but only one status byte can be read at a time (R/W = 1).

**String Format**

S : Start condition - P : Stop condition - A : Acknowledge

*Write Mode*

S	SLAVE ADDRESS	0	A	DATA1	A	DATAN	A	P
---	---------------	---	---	-------	---	-------	---	---

*Read Mode*

S	SLAVE ADDRESS	1	A	STATUS	A	P
---	---------------	---	---	--------	---	---

**Slave Address**

<b>Address</b>	A7	A6	A5	A4	A3	A2	A1	A0
<b>Value</b>	1	0	0	1	0	1	A1	R/W

A1 value depends on voltage on ADD input (V<sub>INADD</sub>) :  
 - A1 = 0 if V<sub>INADD</sub> < 0.4V (typ. : GND). Address : 94H  
 - A1 = 1 if V<sub>INADD</sub> > 3.7V (typ. : V<sub>CC</sub>). Address : 96H

**Control Register (DATA1) (Write Mode)**

		b7	b6	b5	b4	b3	b2	b1	b0
<b>Output Group Selection</b>	Output Group 1	0	0	X	X	X	X	X	X
	Output Group 2	0	1	X	X	X	X	X	X
	Output Group 3	1	0	X	X	X	X	X	X
<b>Input Group Selection</b>	V1	X	X	X	0	0	1	X	X
	V2	X	X	X	0	1	0	X	X
	V3	X	X	X	0	1	1	X	X
	Mute	X	X	1	1	0	0	0	0
	TV	X	X	1	1	0	0	1	0
	BS	X	X	1	1	0	1	1	0
	PIP	X	X	1	1	1	0	1	0
<b>Input Format</b>	MN-Y/MN-C	X	X	1	1	0	1	1	1
	Composite	X	X	X	X	X	X	1	0
<b>SOUT Mode Selection</b>	Y/C	X	X	X	X	X	X	1	1
	SOUT Not Modified	X	X	1	X	X	X	X	X
<b>SOUT Level Selection (Soft Mode)</b>	SOUT Connected to S Input	X	X	0	X	X	X	X	X
	SOUT < 0.8V	1	1	0	0	0	0	0	0
	1.3V < SOUT < 3.5V	1	1	0	0	0	1	0	0
	SOUT > 4.5V	1	1	0	0	1	1	0	0
	High Impedance (> 1MΩ)	1	1	0	0	1	0	0	0

**Status Register (Read Mode)**

b7	b6	b5	b4	b3	b2	b1	b0
S3/b1	S3/b0	S2/b1	S2/b0	S1/b1	S1/b0	ID1-2	ID1-1

**SX/bx** : **SX/b1 SX/b0 Voltage on S Inputs**

0 0 V<sub>IN</sub> < 0.8V  
 0 1 1.3V < V<sub>IN</sub> < 3.5V  
 1 1 V<sub>IN</sub> > 4.5V

**ID1-X** : **Voltage on ID1 Inputs**

0 < 0.4V  
 1 > 3.7V

**I<sup>2</sup>C BUS SELECTION**

**Power-on Reset**

Power-on reset is active when the power supply voltage is over 4V. Then, the device is in the following configuration :

- All outputs except YOUT2 and COUT2 are muted.
- SOUT is in high impedance state.

**PIN CONFIGURATIONS**

**Figure 2 :** Y & CVBS Inputs (Pins 2-6-9-10-12 and Pins 14-15-28-34-40-41-44)

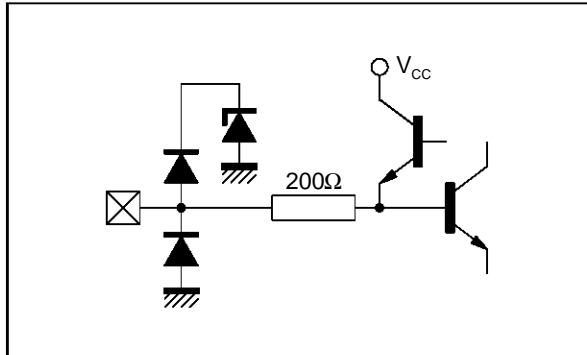

6407-04.EPS

**Figure 3 :** C Inputs (Pins 4-8-16-26-32-42)

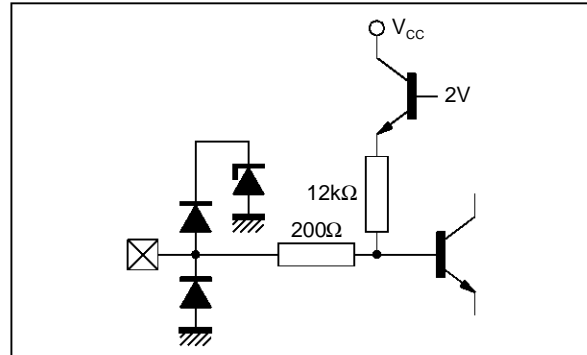

6407-05.EPS

**Figure 4 :** ID1-1, ID1-2 Inputs, Add (Pins 3-5-27)

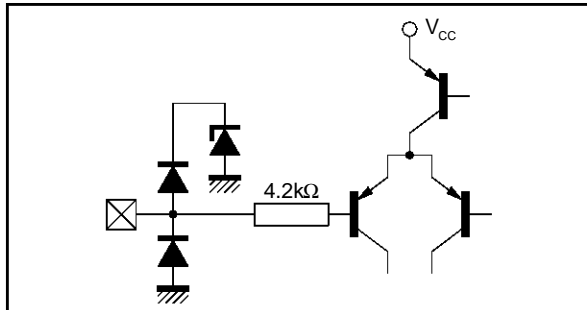

6407-06.EPS

**Figure 5 :** 6dB Amplifier Outputs (Pins 24-25-29-30-31-35-36)

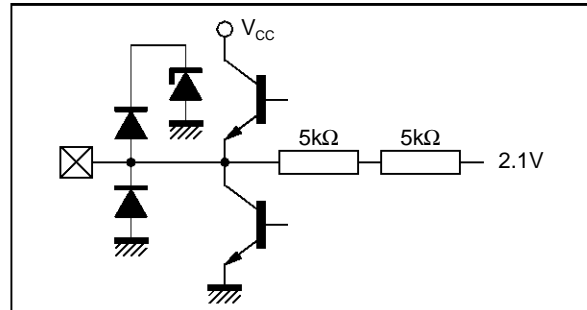

6407-07.EPS

**Figure 6 :** Trap Filter Input (Pin 38)

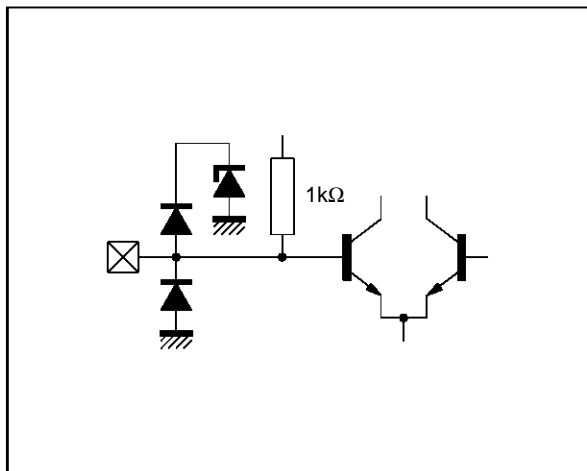

6407-08.EPS

**Figure 7 :** I<sup>2</sup>C Bus Pins SDA, SCL (Pins 20-21)

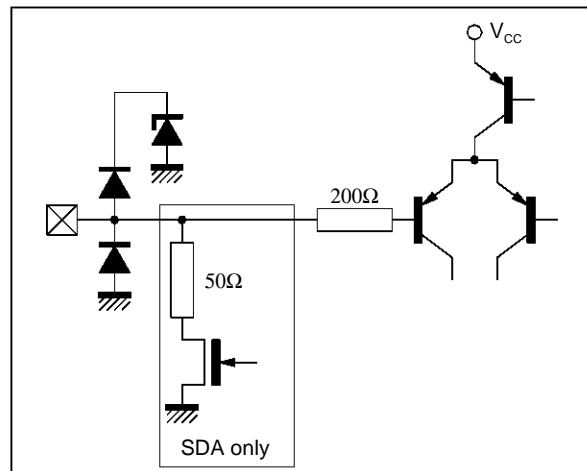

6407-09.EPS

**PIN CONFIGURATIONS** (continued)

**Figure 8 :** OUT Output (Pin 33)

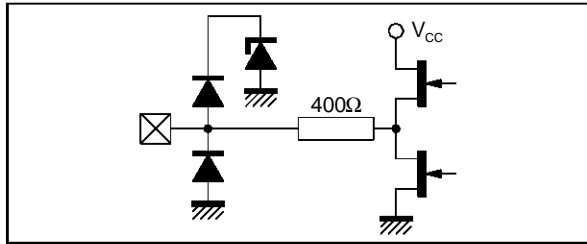

6407-11.EPS

**Figure 9 :** Power Supplies (Pins 18-19)  
(V<sub>CC1</sub> : Analog , V<sub>CC2</sub> : Logic)

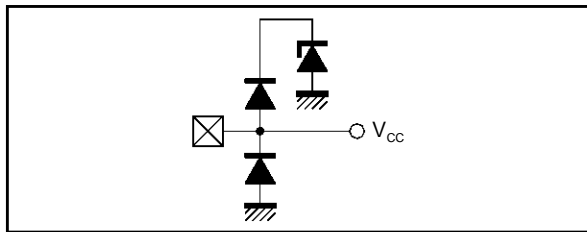

6407-11.EPS

**Figure 10 :** S1, S2, S3 Inputs (Pins 7-13-39)

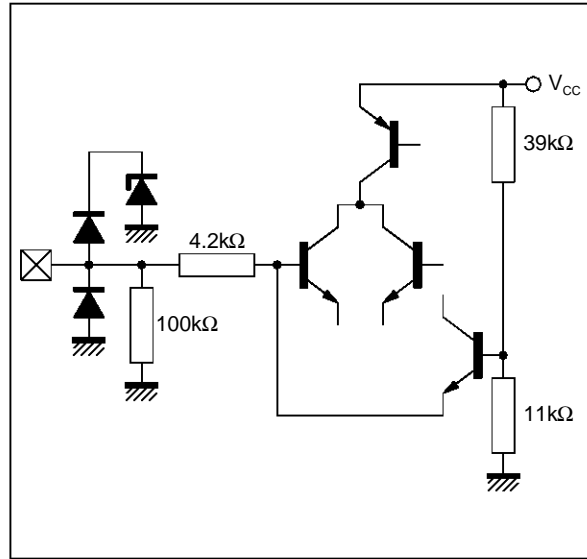

6407-12.EPS

**TYPICAL APPLICATION**

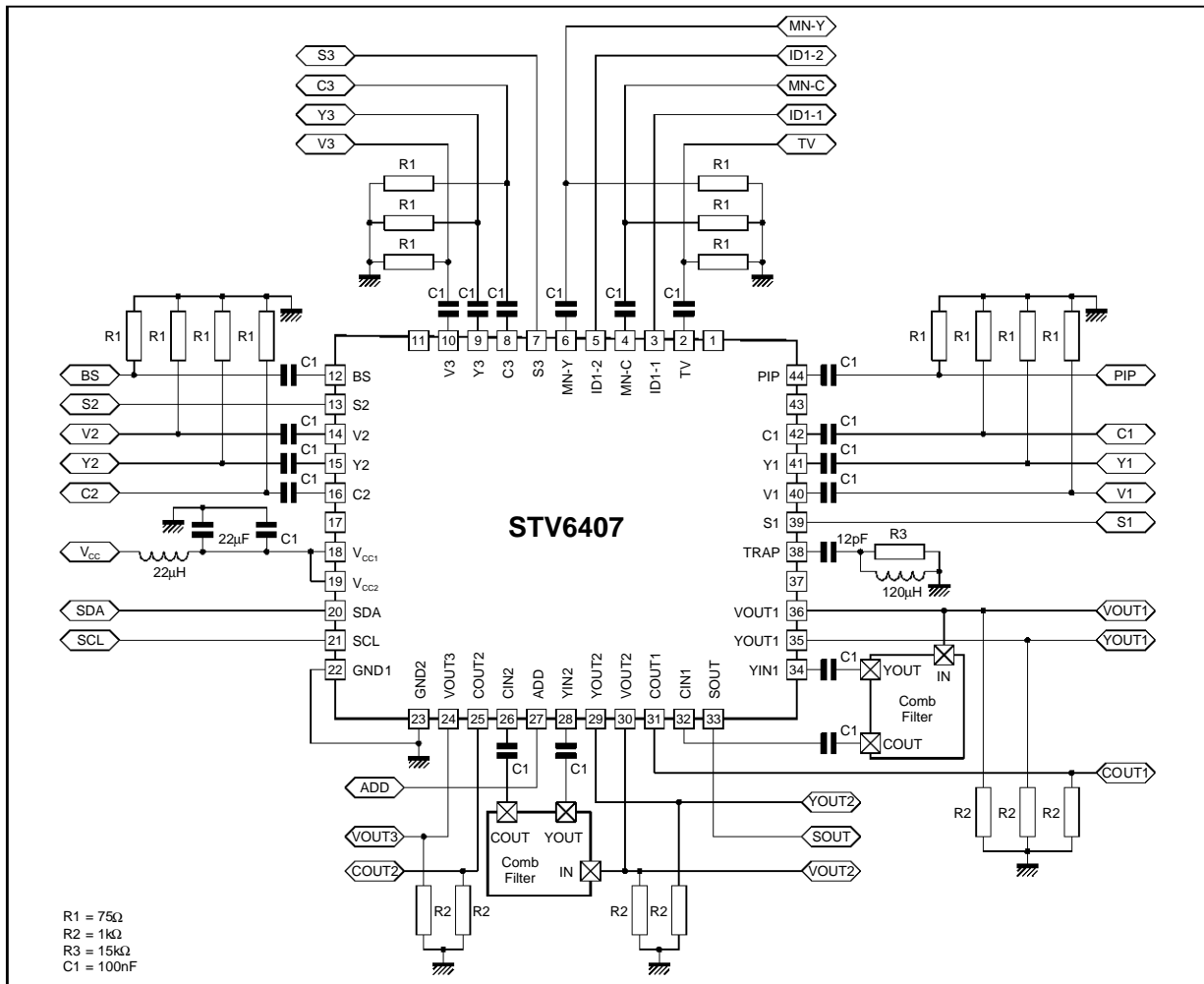

6407-13.EPS

**PACKAGE MECHANICAL DATA**  
44 PINS - PLASTIC QUAD FLAT PACK

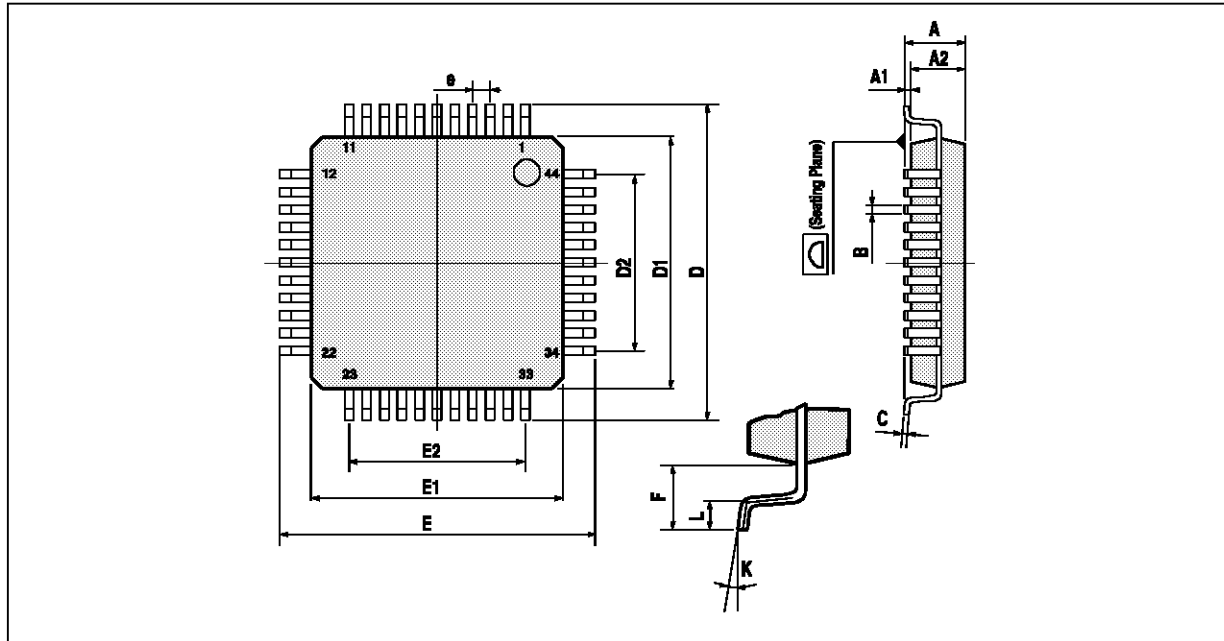

PMP0FP44.WMF

Dimensions	Millimeters			Inches		
	Min.	Typ.	Max.	Min.	Typ.	Max.
A			2.45			0.096
A1	0.25			0.01		
A2	1.95	2.00	2.10	0.077	0.079	0.083
B	0.30		0.45	0.012		0.018
C	0.13		0.23	0.005		0.009
D	12.95	13.20	13.45	0.51	0.52	0.53
D1	9.90	10.00	10.10	0.390	0.394	0.398
D2		8.00			0.315	
e		0.80			0.031	
E	12.95	13.20	13.45	0.510	0.520	0.530
E1	9.90	10.00	10.10	0.390	0.394	0.398
E2		8.00			0.315	
F		1.60			0.063	
K	0° (min.), 7° (max.)					
L	0.65	0.80	0.95	0.026	0.031	0.037

POFP44.TBL

Information furnished is believed to be accurate and reliable. However, SGS-THOMSON Microelectronics assumes no responsibility for the consequences of use of such information nor for any infringement of patents or other rights of third parties which may result from its use. No licence is granted by implication or otherwise under any patent or patent rights of SGS-THOMSON Microelectronics. Specifications mentioned in this publication are subject to change without notice. This publication supersedes and replaces all information previously supplied. SGS-THOMSON Microelectronics products are not authorized for use as critical components in life support devices or systems without express written approval of SGS-THOMSON Microelectronics.

© 1995 SGS-THOMSON Microelectronics - All Rights Reserved

Purchase of I<sup>2</sup>C Components of SGS-THOMSON Microelectronics, conveys a license under the Philips I<sup>2</sup>C Patent. Rights to use these components in a I<sup>2</sup>C system, is granted provided that the system conforms to the I<sup>2</sup>C Standard Specifications as defined by Philips.

SGS-THOMSON Microelectronics GROUP OF COMPANIES

Australia - Brazil - China - France - Germany - Hong Kong - Italy - Japan - Korea - Malaysia - Malta - Morocco  
The Netherlands - Singapore - Spain - Sweden - Switzerland - Taiwan - Thailand - United Kingdom - U.S.A.