MULTISYNC ON-SCREEN DISPLAY FOR MONITOR

- CMOS SINGLE CHIP OSD FOR MONITOR
- BUILT IN 1 KBYTE RAM HOLDING :
 - PAGES' DESCRIPTORS
 - CHARACTER CODES
 - USER DEFINABLE CHARACTERS
- 128 ALPHANUMERIC CHARACTERS OR GRAPHIC SYMBOLS IN INTERNAL ROM (12 x 18 DOT MATRIX)
- UP TO 26 USER DEFINABLE CHARACTERS
- INTERNAL HORIZONTAL PLL (15 TO 120kHz)
- PROGRAMMABLE VERTICAL HEIGHT OF CHARACTER WITH A SLICE INTERPOLATOR TO MEET MULTI-SYNCH REQUIREMENTS
- PROGRAMMABLE VERTICAL AND HORIZONTAL POSITIONING
- FLEXIBLE SCREEN DESCRIPTION
- CHARACTER BY CHARACTER COLOR SELECTION (UP TO 8 DIFFERENT COLORS)
- PROGRAMMABLE BACKGROUND COLOR, TRANSPARENT OR WITH SHADOWING)
- CHARACTER BLINKING
- 2-WIRES ASYNCHRONOUS SERIAL MCU INTERFACE (I²C PROTOCOL)
- 8 x 8 BITS PWM DAC OUTPUTS
- SINGLE POSITIVE 5V SUPPLY

DESCRIPTION

The STV9422/24 is an ON SCREEN DISPLAY for monitor. It is built as a slave peripheral connected to a host MCU via a serial I²C bus. It includes a display memory, controls all the display attributes and generates pixels from the data read in its on chip memory. The line PLL and a special slice interpolator allow to have a display aspect which does not depend on the line and frame frequencies. I²C interface allows MCU to make transparent internal access to prepare the next pages during the display of the current page. Toggle from one page to another by programming only one register.

8 x 8 bits PWM DAC are available to provide DC voltage control to other peripherals.

The STV9422/24 provides the user an easy to use and cost effective solution to display alphanumeric or graphic information on monitor screen.

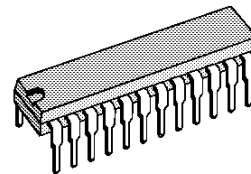

SHRINK 24
(Plastic Package)

ORDER CODE : STV9422

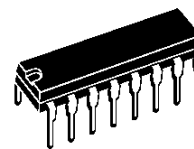

DIP16
(Plastic Package)

ORDER CODE : STV9424

STV9422 - STV9424

PIN CONNECTIONS

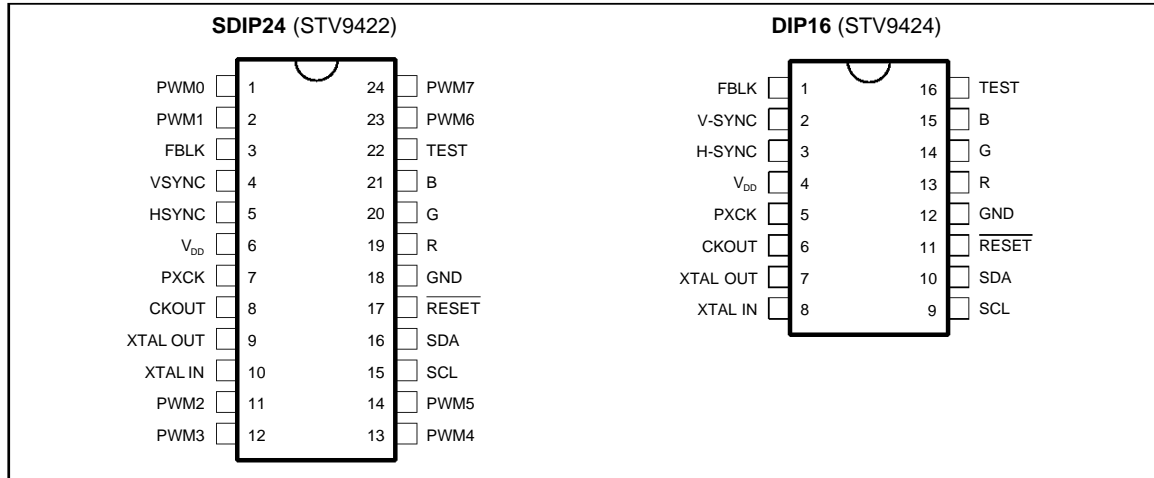

9422-01.EPS / 9424-01.EPS

PIN DESCRIPTION

Symbol	Pin Number		I/O	Description
	SDIP24	DIP16		
PWM0	1	-	O	DAC0 Output
PWM1	2	-	O	DAC1 Output
FBLK	3	1	O	Fast Blanking Output
V-SYNC	4	2	I	Vertical Sync Input
H-SYNC	5	3	I	Horizontal Sync Input
V _{DD}	6	4	S	+5V Supply
PXCK	7	5	O	Pixel Frequency Output
CKOUT	8	6	O	Clock Output
XTAL OUT	9	7	O	Crystal Output
XTAL IN	10	8	I	Crystal or Clock Input
PWM2	11	-	O	DAC2 Output
PWM3	12	-	O	DAC3 Output
PWM4	13	-	O	DAC4 Output
PWM5	14	-	O	DAC5 Output
SCL	15	9	I	Serial Clock
SDA	16	10	I/O	Serial Input/output Data
RESET	17	11	I	Reset Input (Active Low)
GND	18	12	S	Ground
R	19	13	O	Red Output
G	20	14	O	Green Output
B	21	15	O	Blue Output
TEST	22	16	I	Reserved (grounded in Normal Operation)
PWM6	23	-	O	DAC6 Output
PWM7	24	-	O	DAC7 Output

9422-01.TBL

BLOCK DIAGRAMS

STV9422

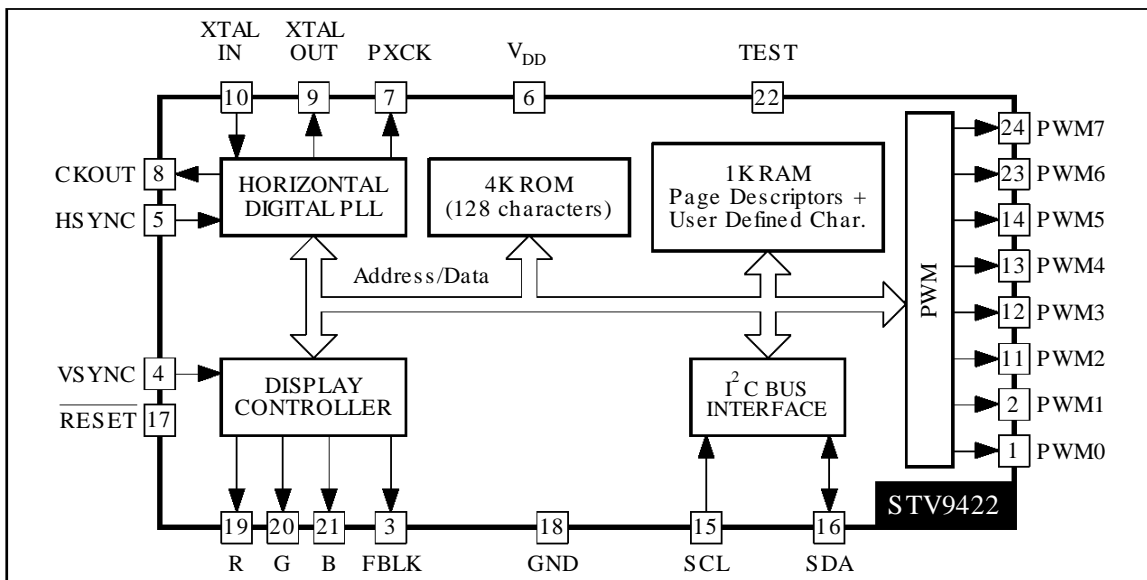

9422-02.EPS

STV9424

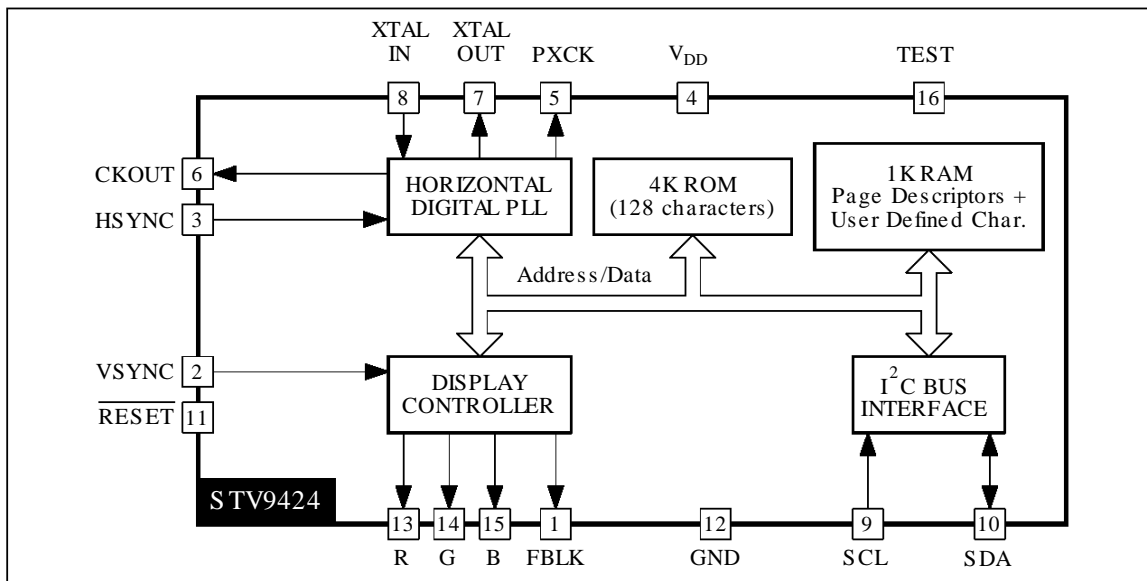

9424-02.EPS

ABSOLUTE MAXIMUM RATINGS

Symbol	Parameter	Value	Unit
V _{DD}	Supply Voltage	-0.3, +7.0	V
V _{IN}	Input Voltage	-0.3, +7.0	V
T _{oper}	Operating Ambient Temperature	0, +70	°C
T _{stg}	Storage Temperature	-40, +125	°C

9422-02.TBL

ELECTRICAL CHARACTERISTICS

(V_{DD} = 5V, V_{SS} = 0V, T_A = 0 to 70°C, F_{XTAL} = 8 to 15MHz, TEST = 0 V, unless otherwise specified)

Symbol	Parameter	Min.	Typ.	Max.	Unit
--------	-----------	------	------	------	------

SUPPLY

V _{DD}	Supply Voltage	4.75	5	5.25	V
I _{DD}	Supply Current	-	-	50	mA

INPUTS

SCL, SDA, TEST, RESET, V-SYNC and H-SYNC					
V _{IL}	Input Low Voltage			0.8	V
V _{IH}	Input High Voltage	0.8V _{DD}			V
I _{IL}	Input Leakage Current	-20		+20	µA

OUTPUTS

R, G, B, FBLK, SDA, CKOUT, PXCK and PWMi (i = 0 to 7)					
V _{OL}	Output Low Voltage (I _{OL} = 1.6mA)	0		0.4	V
V _{OH}	Output High Voltage (I _{OL} = -0.1mA)	0.8V _{DD}		V _{DD}	V

9422-03.TBL

For R, G, B and FBLK outputs, see Figure 1.

Figure 1 : Typical R, G, B Outputs Characteristics

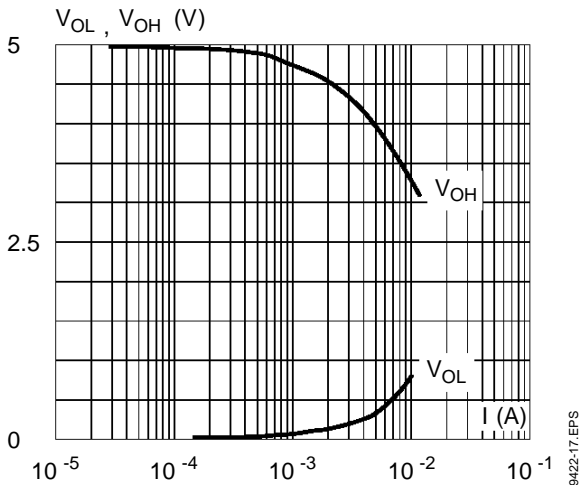

9422-17.EPS

TIMINGS

Symbol	Parameter	Min.	Typ.	Max.	Unit
--------	-----------	------	------	------	------

OSCILATOR INPUT : XTI (see Figure 2)

t_{WH}	Clock High Level	20			ns
t_{WL}	Clock Low Level	20			ns
f_{XTAL}	Clock Frequency	6		15	MHz
f_{PXL}	Pixel Frequency			40	MHz

RESET

t_{RES}	Reset Low Level Pulse	4			μ s
-----------	-----------------------	---	--	--	---------

R, G, B, FBLK ($C_{LOAD} = 30pF$)

t_R	Rise Time (Note 1)		5		ns
t_F	Fall Time (Note 1)		5		ns
t_{SKEW}	Skew between R, G, B, FBLK (Note 1)		5		ns

I²C INTERFACE : SDA AND SCL (see Figure 3)

f_{SCL}	SCL Clock Frequency	0		1	MHz
t_{BUF}	Time the bus must be free between 2 access	500			ns
t_{HDS}	Hold Time for Start Condition	500			ns
t_{SUP}	Set up Time for Stop Condition	500			ns
t_{LOW}	The Low Period of Clock	400			ns
t_{HIGH}	The High Period of Clock	400			ns
t_{HDAT}	Hold Time Data	0			ns
t_{SUDAT}	Set up Time Data	375			ns
t_F	Fall Time of SDA			20	ns
t_R	Rise Time of Both SCL and SDA	Depend on the pull-up resistor and the load capacitance			

Note 1 : These parameters are not tested on each unit. They are measured during our internal qualification procedure which includes characterization on batches coming from corners of our processes and also temperature characterization.

Figure 2

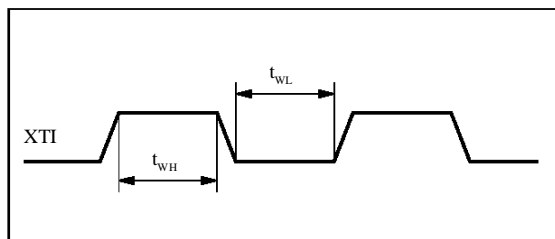
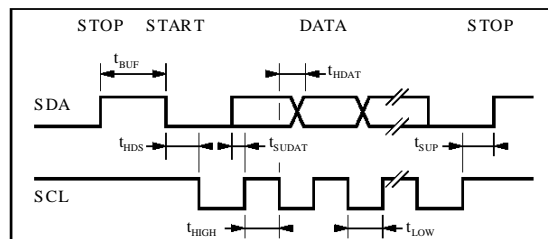

Figure 3



FUNCTIONAL DESCRIPTION

The STV9422/24 display processor operation is controlled by a host MCU via the I²C interface. It is fully programmable through 16 internal read/write registers (8 for STV9424) and performs all the display functions by generating pixels from data stored in its internal memory. After the page downloading from the MCU, the STV9422/24 refreshes screen by its built in processor, without any MCU control (access). In addition, the host MCU has a direct access to the on chip 1Kbytes RAM during the display of the current page to make any update of its contents.

With the STV9422/24, a page displayed on the screen is made of several strips which can be of 2 types : spacing or character and which are described by a table of descriptors and character codes in RAM. Several pages can be downloaded at the same time in the RAM and the choice of the current display page is made by programming the CONTROL register.

I - Serial Interface

The 2-wires serial interface is an I²C interface. To be connected to the I²C bus, a device must own its slave address ; the slave address of the STV9422/24 is BA (in hexadecimal).

A6	A5	A4	A3	A2	A1	A0	R/W
1	0	1	1	1	0	1	

I.1 - Data Transfer in Write Mode

The host MCU can write data into the STV9422/24 registers or RAM.

To write data into the STV9422/24, after a start, the MCU must send (Figure 3) :

- First, the I²C address slave byte with a low level for the R/W bit,
- The two bytes of the internal address where the MCU wants to write data(s),
- The successive bytes of data(s).

All bytes are sent MS bit first and the write data transfer is closed by a stop.

I.2 - Data Transfer in Read Mode

The host MCU can read data from the STV9422/24 registers, RAM or ROM.

To read data from the STV9422/24 (Figure 4), the MCU must send 2 different I²C sequences.

The first one is made of I²C slave address byte with R/W bit at low level and the 2 internal address bytes.

The second one is made of I²C slave address byte with R/W bit at high level and all the successive data bytes read at successive addresses starting from the initial address given by the first sequence.

Figure 3 : STV9422/I²C Write Operation

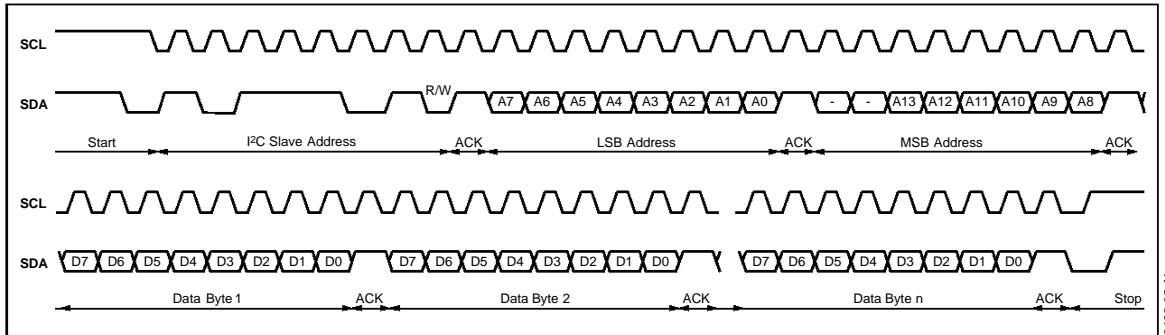
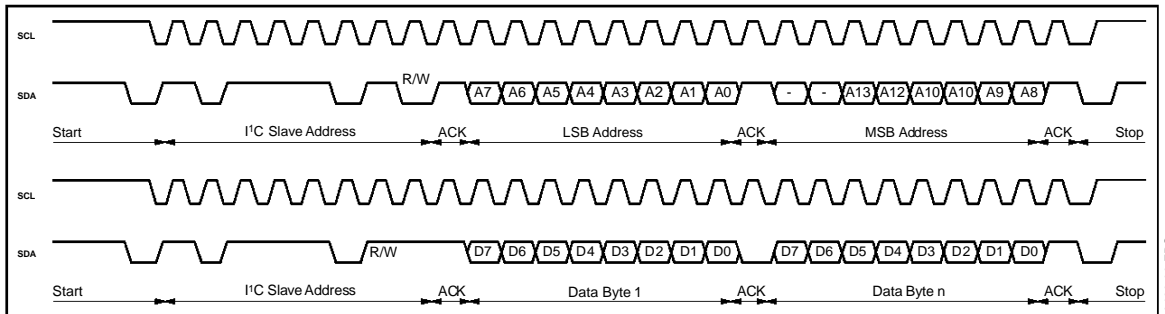

Figure 4 : STV9422/I²C Read Operation



FUNCTIONAL DESCRIPTION (continued)

I.3 - Addressing Space

STV9422/24 registers, RAM and ROM are mapped in a 16Kbytes addressing space. The mapping is the following :

0000	1024 bytes RAM	Descriptors character codes user definable characters
03FF 0400		
1FFF 2000	Empty Space	
32FF 3300	Character Generator ROM	
33FF 3300	Empty Space	
3FFF 3FF0	Internal Registers	
3FFF		

I.4 - Register Set

LINE DURATION

3FF0	VSP	HSP	LD5	LD4	LD3	LD2	LD1	LD0
*	0	0	1	1	1	1	1	1

VSP : V-SYNC active edge selection
= 0 : falling egde, = 1 : rising edge

HSP : H-SYNC active edge selection
= 0 : falling egde, = 1 : rising edge

LD[5:0] : LINE DURATION
(number of pixel period per line divided by 12 ie. Unit = 12 pixel periods).

HORIZONTAL DELAY

3FF1	DD7	DD6	DD5	DD4	DD3	DD2	DD1	DD0
*	0	0	0	0	1	0	0	0

DD[7:0] : HORIZONTAL DISPLAY DELAY from the H-SYNC reference falling edge to the 1st pixel position of the character strips. Unit = 3 pixel periods.

CHARACTERS HEIGHT

3FF2	-	-	CH5	CH4	CH3	CH2	CH1	CH0
*	-	-	0	1	0	0	1	0

CH[5:0] : HEIGHT of the character strips in scan lines. For each scan line, the number of the slice which is displayed is given by :
SLICE-NUMBER =

$$\text{round} \left(\frac{\text{SCAN-LINE} \pm \text{NUMBER} \times 18}{\text{CH}[5:0]} \right)$$

SCAN-LINE-NUMBER = Number of the current scan line of the strip.

DISPLAY CONTROL

3FF3	OSD	FBK	FL1	FL0	-	P8	P7	P6
*	0	0	0	0	-	0	0	0

OSD : ON/OFF (if 0, R, G, B and FBLK are 0).

FBK : Fast blanking control :
= 1 : FBLK = 1, forcing black where there is no display,
= 0 : FBLK is active only during character display.

FL[1:0] : Flashing mode :
- 00 : No flashing. The character attribute is ignored,
- 01 : 1/1 flashing (a duty cycle = 50%),
- 10 : 1/3 flashing,
- 11 : 3/1 flashing.

P[8:6] : Address of the 1st descriptor of the current displayed pages.
P[13:9] and P[5:0] = 0 ; up to 8 different pages can be stored in the RAM.

LOCKING CONDITION TIME CONSTANT

3FF4	FR	AS2	AS1	AS0	-	BS2	BS1	BS0
*	0	0	1	0	-	0	1	0

FR : Free Running ; if = 1 PLL is disabled and the pixel frequency keeps its last value.

AS[2:0] : Phase constant during locking conditions.

BS[2:0] : Frequency constant during locking conditions.

CAPTURE PROCESS TIME CONSTANT

3FF5	-	AF2	AF1	AF0	-	BF2	BF1	BF0
*	-	0	1	1	-	0	1	1

AF[2:0] : Phase constant during the capture process.

BF[2:0] : Frequency constant during the capture process.

INITIAL PIXEL PERIOD

3FF6	PP7	PP6	PP5	PP4	PP3	PP2	PP1	PP0
*	0	0	1	0	1	0	0	0

PP[7:0] : Value to initialize the pixel period of the PLL.

FREQUENCY MULTIPLIER

3FF7	-	-	-	-	FM3	FM2	FM1	FM0
*	-	-	-	-	1	0	1	0

FM[3:0] : Frequency multiplier of the crystal frequency to reach the high frequency used by the PLL to derive the pixel frequency.

FUNCTIONAL DESCRIPTION (continued)

The last fourth registers described below are only available with the STV9422 :

PULSE WIDTH MODULATOR 0 (STV9422)

3FF8	V07	V06	V05	V04	V03	V02	V01	V00
*	0	0	0	0	0	0	0	0

V0[7:0] : Digital value of the 1st PWM D to A converter (Pin1).

PULSE WIDTH MODULATOR 1 (STV9422)

3FF9	V17	V16	V15	V14	V13	V12	V11	V10
*	0	0	0	0	0	0	0	0

V1[7:0] : Digital value of the 2nd PWM DAC (Pin2).

PULSE WIDTH MODULATOR 2 (STV9422)

3FFA	V27	V26	V25	V24	V23	V22	V21	V20
*	0	0	0	0	0	0	0	0

V2[7:0] : Digital value of the 3rd PWM DAC (Pin11).

PULSE WIDTH MODULATOR 3 (STV9422)

3FFB	V37	V36	V35	V34	V33	V32	V31	V30
*	0	0	0	0	0	0	0	0

V3[7:0] : Digital value of the 4th PWM DAC (Pin12).

PULSE WIDTH MODULATOR 4 (STV9422)

3FFC	V47	V46	V45	V44	V43	V42	V41	V40
*	0	0	0	0	0	0	0	0

V4[7:0] : Digital value of the 5th PWM DAC (Pin13).

PULSE WIDTH MODULATOR 5 (STV9422)

3FFD	V57	V56	V55	V54	V53	V52	V51	V50
*	0	0	0	0	0	0	0	0

V5[7:0] : Digital value of the 6th PWM DAC (Pin14).

PULSE WIDTH MODULATOR 6 (STV9422)

3FFE	V67	V66	V65	V64	V63	V62	V61	V60
*	0	0	0	0	0	0	0	0

V6[7:0] : Digital value of the 7th PWM DAC (Pin23).

PULSE WIDTH MODULATOR 7 (STV9422)

3FFF	V77	V76	V75	V74	V73	V72	V71	V70
*	0	0	0	0	0	0	0	0

V7[7:0] : Digital value of the 8th PWM DAC (Pin24).

Note : * is power on reset value.

II - Descriptors

SPACING

MSB	0	-	-	-	-	-	-	-
LSB	SL7	SL6	SL5	SL4	SL3	SL2	SL1	SL0

SL[7:0] : The number of the scan lines of the spacing strip (1 to 255).

CHARACTER

MSB	1	DE	-	ZY	-	-	C9	C8
LSB	C7	C6	C5	C4	C3	C2	C1	0

C[9:0] : The address of the first character code of the strip (even).

DE : Display enable :
 - DE = 0, R = G = B = 0 and FBLK = FBK (display control register) on whole strip,
 - DE = 1, display of the characters.

ZY : Zoom, ZY = 1 all the scan lines are repeated once.

III - Code Format

MSB	SET	CHARACTER NUMBER						
LSB	BK3	BK2	BK1	BK0	FL	RF	GF	BF

SET : The set CHARACTER NUMBER
 - If SET = 0 : ROM character,
 - If SET = 1 :
 • If CHARACTER NUMBER is 0 to 25, a user redefinable character (UDC) located in RAM at the address equal to :
 38 x CHARACTER NUMBER,
 • If CHARACTER NUMBER is 26 to 63, space character,
 • If CHARACTER NUMBER > 63, end of line.

FL : Flashing attribute (the flashing mode is defined in the DISPLAY CONTROL register).

RF, GF, BF : Foreground color.

BK[3:0] : Background :
 - If BK3 = 0, BK[2:0] = background color R, G and B,
 - If BK3 = 1, shadowing :
 • BK2 : vertical shadowing,
 • BK1 : horizontal shadowing.
 (if BK2 = BK1 = 0, the background is transparent).

FUNCTIONAL DESCRIPTION (continued)

Figure 5 : Horizontal Timing

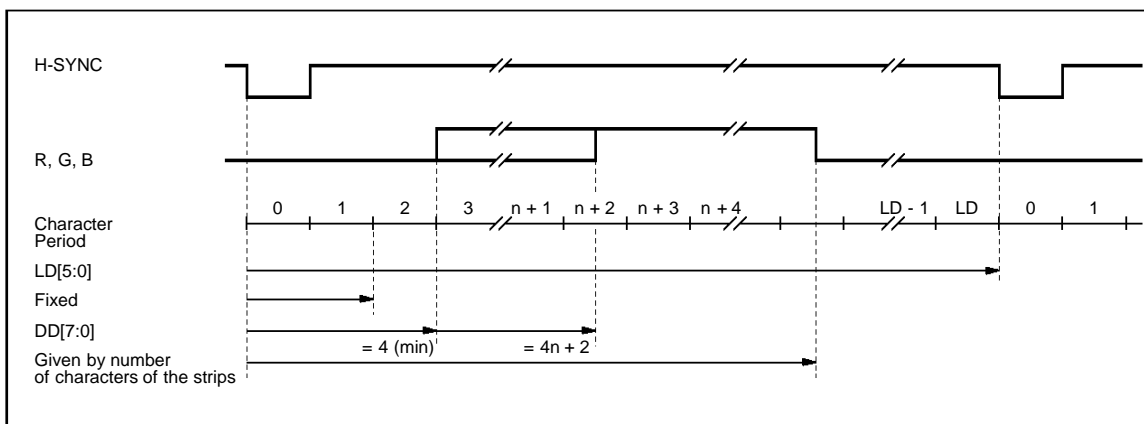

IV - Clock and Timing

The whole timing is derived from the XTALIN and the SYNCHRO (horizontal and vertical) input frequencies. The XTALIN input frequency can be an external clock or a crystal signal thanks to XTALIN/XTALOUT pins. The value of this frequency can be chosen between 8 and 15MHz, it is available on the CKOUT pin and is used by the PLL to generate a pixel clock locked on the horizontal synchro input signal.

IV.1 - Horizontal Timing (see Figure 5)

The number of pixel periods is given by the LINE DURATION register and is equal to : $[LD[5:0] + 1] \times 12$.
(LD[5:0] : value of the LINE DURATION register).

This value allows to choose the horizontal size of the characters. The horizontal left margin is given by the HORIZONTAL DELAY register and is equal to : $[DD[7:0] + 8] \times 3 \times T_{PXCK}$
(DD[7:0] : value of the DISPLAY DELAY register and T_{PXCK} : pixel period).

This value allows to choose the horizontal position of the characters on the screen. The value of DD[7:0] must be equal or greater than 4 (the minimum value of the horizontal delay is $36 \times T_{PXCK} = 3$ character periods). The length of the active area, where R, G, B are different from 0, depends on the number of characters of the strips.

IV.2 - D to A Timing (STV9422)

The D to A converters of the STV9422 are pulse width modulator converter.

The frequency of the output signal is : $\frac{f_{XTAL}}{256}$

and the duty cycle is : $\frac{Vi[7:0]}{256}$ per cent.

After a low pass filter, the average value of the output is : $\frac{Vi[7:0]}{256} \cdot V_{DD}$

V - Display Control

A screen is composed of successive scanlines gathered in several strips. Each strip is defined by a descriptor stored in memory. A table of descriptors allows screen composition and different tables can be stored in memory at the page addresses (8 possible \neq addresses).

Two types of strips are available :

- Spacing strip : its descriptor (see II) gives the number of black (FBK = 1 in DISPLAY CONTROL register) or transparent (FBK = 0) lines.
- Character strip : its descriptor gives the memory address of the character codes corresponding to the 1st displayed character. The characters and attributes (see code format III) are defined by a succession of codes stored in the RAM at addresses starting from the 1st one given by the descriptor. A character strip can be displayed or not by using the DE bit of its descriptor. A zoom can be made on it by using the ZY bit.

Figure 6 : PWM Timing

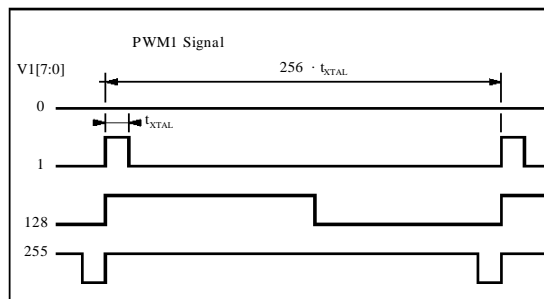

FUNCTIONAL DESCRIPTION (continued)

After the falling edge on V-SYNC, the first strip descriptor is read at the top of the current table of descriptors at the address given by P[9:0] (see DISPLAY CONTROL register).
 If it is a spacing strip, SL[7:0] black or transparent scan lines are displayed.
 If it is a character strip, during CH[5:0] x (1 + ZY)

scan lines (CH[5:0] given by the CHARACTER HEIGHT register), the character codes are read at the addresses starting from the 1st one given by the descriptor until a end of line character or the end of the scan line.
 The next descriptor is then read and the same process is repeated until the next falling edge on V-SYNC.

Figure 7 : Relation between Screen/Address Page/CharacterCode in RAM

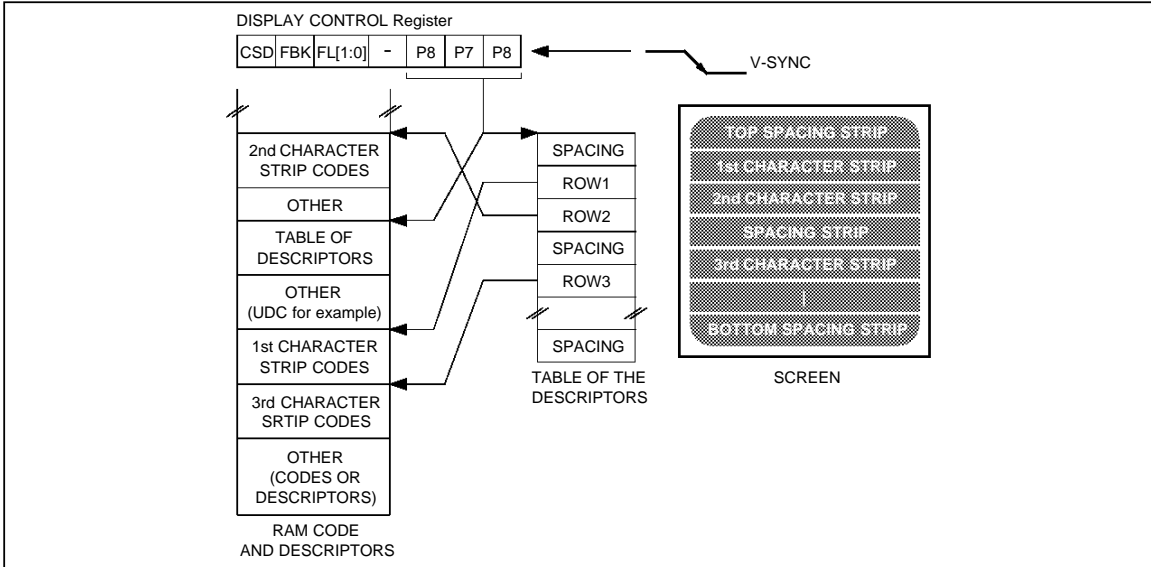
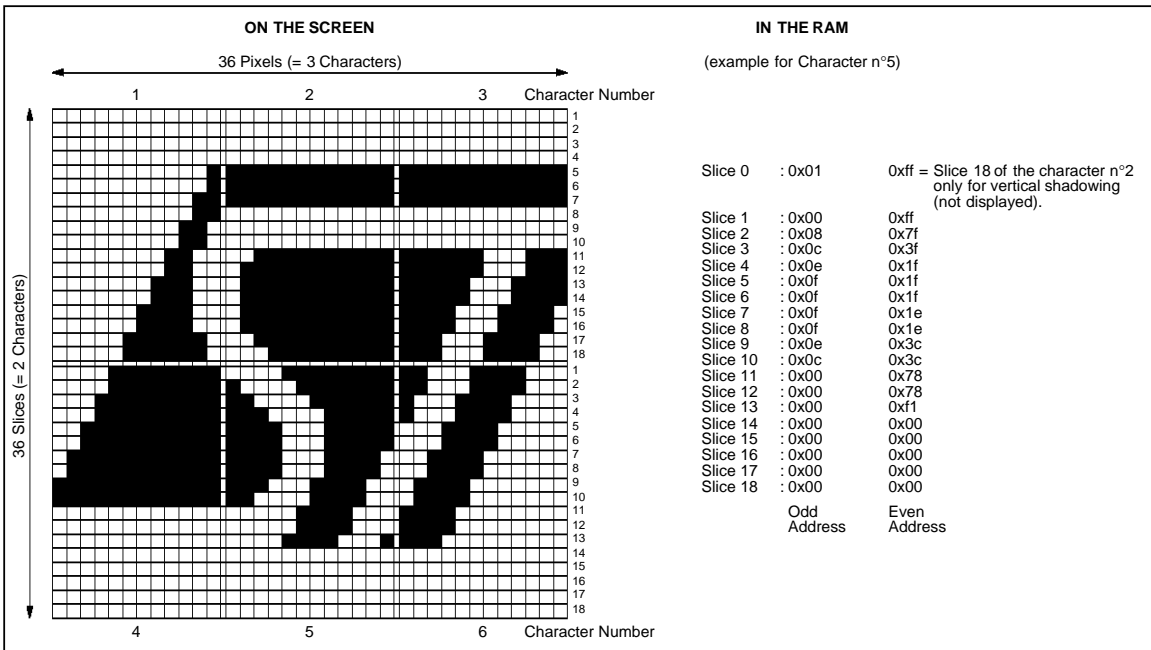

Figure 8 : User Definable Character



FUNCTIONAL DESCRIPTION (continued)

Table 1 : ROM Character Generator

CHARACTER NUMBER C(6:0)		0	1	2	3	4	5	6	7
C(3:0)	0	0	1	a	o	O	P	p	q
	1	2	e	1	A	Q	a	o	
	2	3	u	2	B	R	r		
	3	4	e	3	C	S	s		
	4	5	o	4	D	T	t		
	5	6	e	5	E	U	u		
	6	7	v	6	F	V	v		
	7	8	7	G	W	w			
	8	9	8	H	X	x			
	9	a	9	I	Y	y			
	a	b	0	:	J	Z	j	z	
	b	c	1	;	K	A	k	a	
	c	d	2	+	L	O	l	o	
	d	e	3	=	M	I	m	i	
	e	f	4	-	N	U	n	u	
	f		5	/	0	o	0	o	

9422-11.EPS

FUNCTIONAL DESCRIPTION (continued)

VI - User Definable Character

The STV9422/24 allows the user to dynamically define character(s) for his own needs (for a special LOGO for example). Like the ROM characters, a UDC is made of a 12 pixels x 18 slices dot matrix, but one more slice is added for the vertical shadowing when several UDCs are gathered to make a special great character (see Figure 8).

In a UDC, each pixel is defined with a bit, 1 refers to foreground, and 0 to background color. Each slice of a UDC uses 2 bytes :

add +	-	-	-	-	PX11	PX10	PX9	PX8
add (even)	PX7	PX6	PX5	PX4	PX3	PX2	PX1	PX0

PX11 is the left most pixel. Character slice address :
SLICE ADDRESS = 38 x (CHARACTER NUMBER) + (SLICE NUMBER).

Where :

- CHARACTER NUMBER is the number given by the character code,
- SLICE NUMBER is the number given by the slice interpolator (n° of the current slice of the strip : 1 < n < 18)

VII - ROM Character Generator

The STV9422/24 includes a ROM character generator which is made of 128 alphanumeric or graphic characters (see Table 1)

VIII - PLL

The PLL function of the STV9422/24 provides the internal pixel clock locked on the horizontal synchro signal and used by the display processor to generate the R, G, B and fast blanking signals. It is made of 2 PLLs. The first one analogic (see Figure 9), provides a high frequency signal locked on the crystal frequency. The frequency multiplier is given by :

$$N = 2 \cdot (FM[3:0] + 3)$$

Where FM[3:0] is the value of the FREQUENCY MULTIPLIER register.

Figure 9 : Analogic PLL

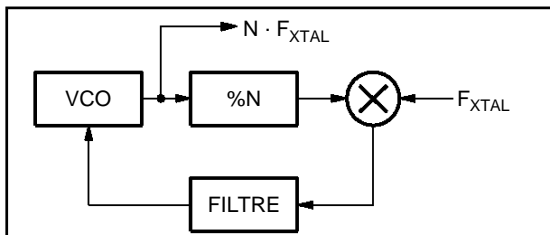

The second PLL, full digital (see Figure 10), provides a pixel frequency locked on the horizontal synchro signal. The ratio between the frequencies of these 2 signals is :

$$M = 12 \times (LD[5:0] + 1)$$

Where LD[5:0] is the value of the LINE DURATION register.

Figure 10 : Digital PLL

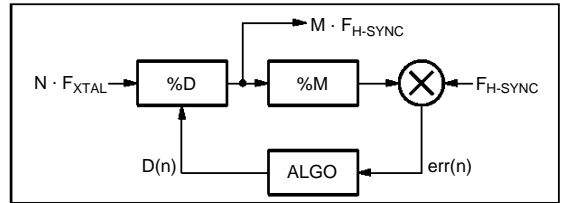

VIII.1 - Programming of the PLL Registers

Frequency Multiplier (@3FF7)

This register gives the ratio between the crystal frequency and the high frequency of the signal used by the 2nd PLL to provide, by division, the pixel clock. The value of this high frequency must be near to 200MHz (for example if the crystal is a 8MHz, the value of FM must be equal to 10) and greater than 6 x (pixel frequency).

Initial Pixel Period (@3FF6)

This register allows to increase the speed of the convergence of the PLL when the horizontal frequency changes (new graphic standart). The relationship between FM[3:0], PP[7:0], LD[5:0], F_HSYNC and F_XTAL is :

$$PP[7:0] = \text{round} \left(8 \cdot \frac{2 \cdot (FM[3:0] + 3) \cdot F_{XTAL}}{12 \cdot (LD[5:0] + 1) \cdot F_{HSYNC}} \pm 24 \right)$$

Locking Condition Time Constant (@ 3FF4)

This register gives the constants AS[2:0] and BS[2:0] used by the algo part of the PLL (see Figure 10) to calculate, from the phase error, err(n), the new value, D(n), of the division of the high frequency signal to provide the pixel clock. These two constants are used only in locking condition, which is true, if the phase error is less than a fixed value during at least, 4 scan lines. If the phase error becomes greater than the fixed value, the PLL is not in locking condition but in capture process. In this case, the algo part of the PLL used the other constants, AF[2:0] and BF[2:0], given by the next register.

Capture Process Time Constant (@ 3FF5)

The choice between these two time constants (locking condition or capture process) allows to decrease the capture process time by changing the time response of the PLL.

FUNCTIONAL DESCRIPTION (continued)

VIII.2 - How to choose the value of the time constant ?

The time response of the PLL is given by its characteristic equation which is :

$$(x \pm 1)^2 + (\alpha + \beta) \cdot (x \pm 1) + \beta = 0.$$

Where :

$\alpha = 3 \cdot LD[5:0] \cdot 2^{A \pm 11}$ and $\beta = 3 \cdot LD[5:0] \cdot 2^{B \pm 19}$.
 (LD[5:0] = value of the LINE DURATION register, A = value of the 1st time constant, AF or AS and B = value of the 2^d time constant, BF or BS).

As you can see, the solution depend only on the LINE DURATION and the TIME CONSTANTS given by the I²C registers.

If $(\alpha + \beta)^2 \pm 4\beta \geq 0$ and $2\alpha \pm \beta < 4$, the PLL is stable and its response is like this presented on Figure 11.

Figure 11 : Time Response of the PLL/Characteristic Equation Solutions (with Real Solutions)

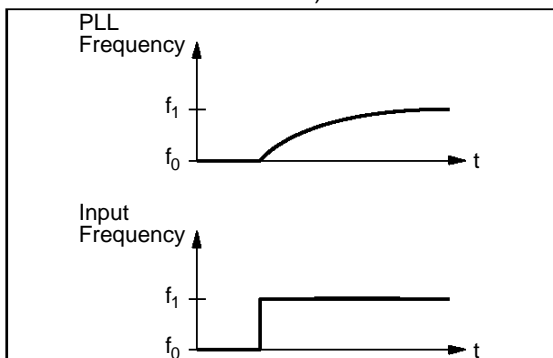

If $(\alpha + \beta)^2 \pm 4\beta \leq 0$, the response of the PLL is like this presented on Figure 12.

In this case the PLL is stable if $\tau > 0.7$ damping coefficient).

Figure 12 : Time Response of the PLL/Characteristic Equation Solutions (with Complex Solutions)

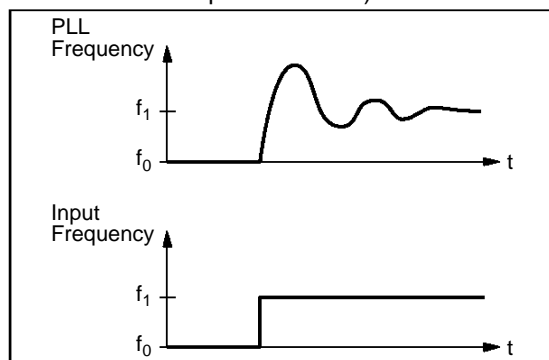

The Table 2 gives some good values for A and B constants for different values of the LINE DURATION.

Summary

For a good working of the PLL :

- A and B time constants must be chosen among values for which the PLL is stable,
- B must be equal or greater than A and the difference between them must be less than 3,
- The greater (A, B) are, the faster the capture is.

An optimal choice for the most of applications might be :

- For locking condition : AS = 0 and BS = 1,
- For capture process : AS = 2 and BS = 4.

But for each application the time constants can be calculated by solving the characteristic equation and choosing the best response.

Table 2 : Valid Time Constants Examples

B \ A	0	1	2	3	4	5	6
0	YYYY	YYYY	YYYY	YYYN	YNNN	NNNN	NNNN
1	YYYY	YYYY	YYYY	YYYN	YNNN	NNNN	NNNN
2	NYYY	YYYY	YYYY	YYYN	YNNN	NNNN	NNNN
3	NNNY	YYYY	YYYY	YYYN	YNNN	NNNN	NNNN
4	NNNN	NYYY ⁽¹⁾	YYYY	YYYN	YNNN	NNNN	NNNN
5	NNNN	NNNY	YYYY	YYYN	YNNN	NNNN	NNNN
6	NNNN	NNNN	NYYY	YYYN	YNNN	NNNN	NNNN
7	NNNN	NNNN	NNNY	YYYN	YNNN	NNNN	NNNN

Note : 1. Case of A[2:0] = 1 (001) and B[2:0] = 4 (100) :

LD	16	32	48	63
Valid Time Constants	N	Y	Y	Y

Value of LINE DURATION Register (@ 3FF0) :

LD = 16 : LD[5:0] = 010000
 LD = 32 : LD[5:0] = 100000
 LD = 48 : LD[5:0] = 110000
 LD = 63 : LD[5:0] = 111111

Table meaning :
 N = No possible capture
 Y = PLL can lock

STV9422 - STV9424

PACKAGE MECHANICAL DATA (STV9424) 16 PINS - PLASTIC DIP

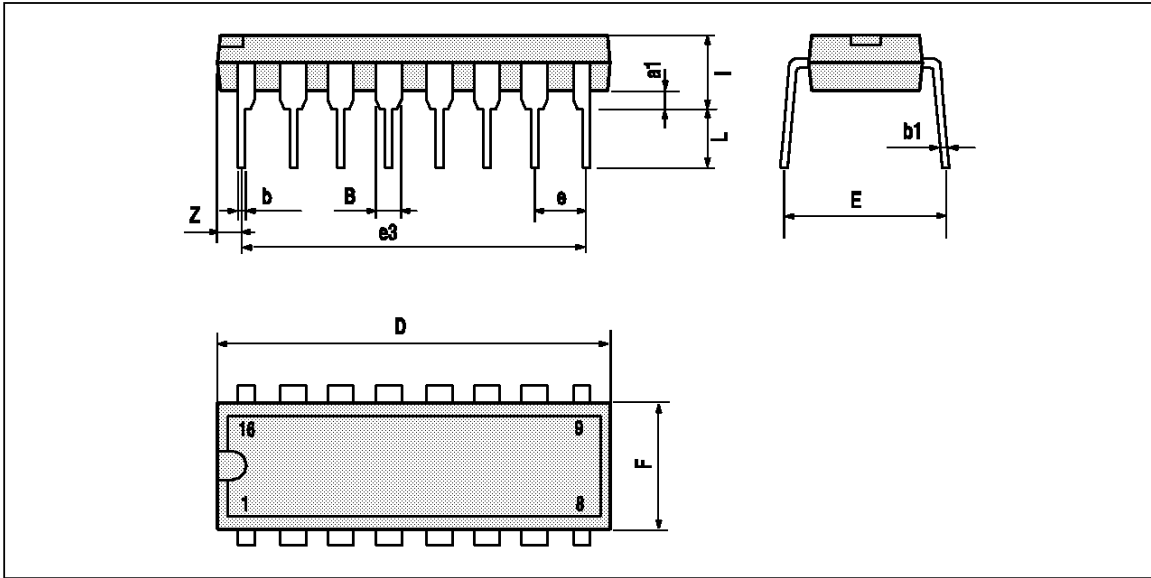

PM-DIP16.WMF

Dimensions	Millimeters			Inches		
	Min.	Typ.	Max.	Min.	Typ.	Max.
a1	0.51			0.020		
B	0.77		1.65	0.030		0.065
b		0.5			0.020	
b1		0.25			0.010	
D			20			0.787
E		8.5			0.335	
e		2.54			0.100	
e3		17.78			0.700	
F			7.1			0.280
l			5.1			0.201
L		3.3			0.130	
Z			1.27			0.050

DIP16.TBL

PACKAGE MECHANICAL DATA (STV9422)
 24 PINS - PLASTIC SHRINK DIP

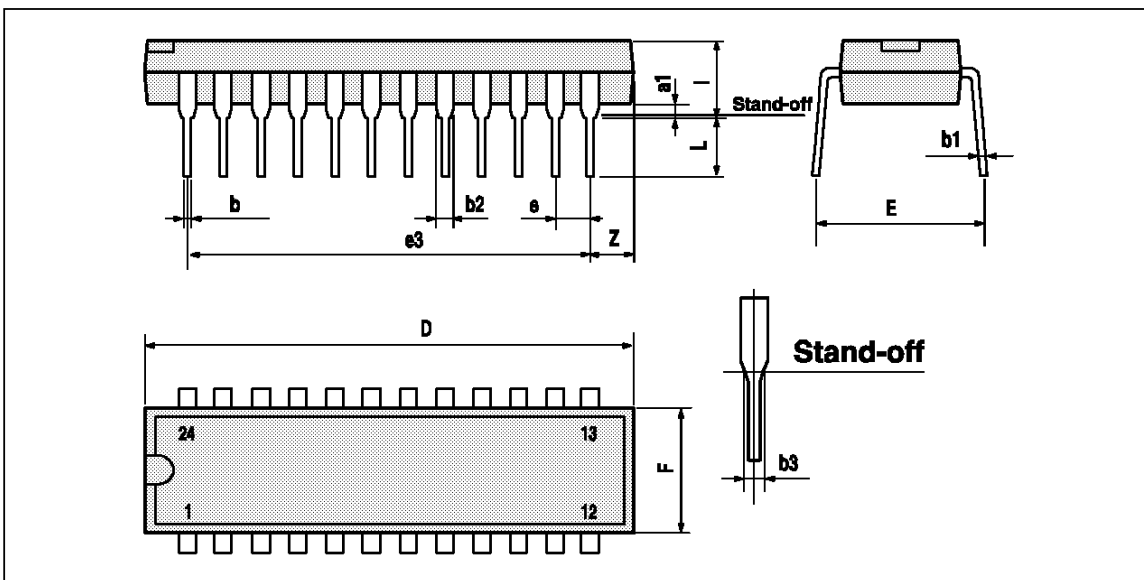

PMSDIP24.WMF

Dimensions	Millimeters			Inches		
	Min.	Typ.	Max.	Min.	Typ.	Max.
a1	0.51			0.020		
b	0.36	0.46	0.56	0.0142	0.0181	0.0220
b1	0.23	0.25	0.38	0.0090	0.0098	0.0150
b2	0.76	1.02	1.4	0.030	0.040	0.045
b3	0.76	1.02	1.4	0.030	0.040	0.045
D	22.61	22.86	23.11	0.890	0.90	0.910
E	7.62		8.64	0.30		0.340
e		1.778			0.070	
e3		19.558			0.770	
e4		7.62			0.300	
F	6.10	6.40	6.86	0.240	0.252	0.270
L			5.08			0.200
L	2.54	3.30	3.81	0.10	0.130	0.150

SDIP24.TEL

Information furnished is believed to be accurate and reliable. However, SGS-THOMSON Microelectronics assumes no responsibility for the consequences of use of such information nor for any infringement of patents or other rights of third parties which may result from its use. No licence is granted by implication or otherwise under any patent or patent rights of SGS-THOMSON Microelectronics. Specifications mentioned in this publication are subject to change without notice. This publication supersedes and replaces all information previously supplied. SGS-THOMSON Microelectronics products are not authorized for use as critical components in life support devices or systems without express written approval of SGS-THOMSON Microelectronics.

© 1995 SGS-THOMSON Microelectronics - All Rights Reserved

Purchase of I^2C Components of SGS-THOMSON Microelectronics, conveys a license under the Philips I^2C Patent. Rights to use these components in a I^2C system, is granted provided that the system conforms to the I^2C Standard Specifications as defined by Philips.

SGS-THOMSON Microelectronics GROUP OF COMPANIES

Australia - Brazil - China - France - Germany - Hong Kong - Italy - Japan - Korea - Malaysia - Malta - Morocco
 The Netherlands - Singapore - Spain - Sweden - Switzerland - Taiwan - Thailand - United Kingdom - U.S.A.