

TOSHIBA BIPOLAR LINEAR INTEGRATED CIRCUIT SILICON MONOLITHIC

TA8132AN, TA8132AF, TA2012N, TA2012F**3V AM / FM IF + MPX****(for Digital Tuning System)**

TA8132AN, TA8132AF and TA2012N, TA2012F are the AM / FM IF + ST DET system ICs, which are designed for DTS Radios.

These are included many functions and these can be used for Digital Tuning System with IF Counter.

FEATURES

- Built-in AM / FM IF and FM stereo PLL multiplex decoder.
- Suitable for combination with digital tuning system which is included IF counter.
 - One terminal type AM / FM IF count output (Auto stop signal) for IF counter of digital tuning system.

FM : 10.7MHz	}	changeable by external switch
1.3375MHz (1 / 8 dividing)		
AM : 450kHz		
 - Built-in mute circuit for IF count output. It is controlled by the IF request signal from digital tuning system,

Pin⑧ level :	High→Come out
	Low →Non output
 - Adjustable for IF count output sensitivity by external resistance of pin ②.
- For adopting ceramic discriminator and ceramic resonator, it is not necessary to adjust the FM quad detector circuit and FM ST DET VCO circuit.
- S curve characteristics of FM detection output in TA8132AN, TA8132AF and TA2012N, TA2012F are reverse to each other.

TA8132AN, TA8132AF :	Reverse characteristic.
TA2012N, TA2012F :	Normal characteristic.
- Built-in one terminal type AM low cut circuit.
- TA2053F is reverse pin type of TA2012F.
- Operating supply voltage range (Ta = 25°C)
VCC (opr.) = 1.8~8.0V

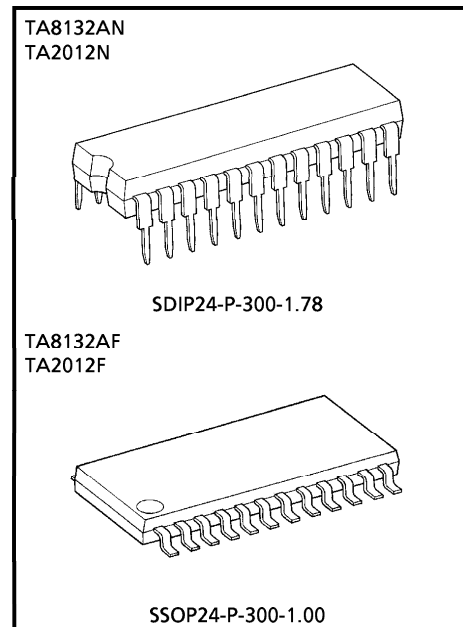

Weight
SDIP24-P-300-1.78 : 1.2g (Typ.)
SSOP24-P-300-1.00 : 0.31g (Typ.)

980910EBA2

- TOSHIBA is continually working to improve the quality and the reliability of its products. Nevertheless, semiconductor devices in general can malfunction or fail due to their inherent electrical sensitivity and vulnerability to physical stress. It is the responsibility of the buyer, when utilizing TOSHIBA products, to observe standards of safety, and to avoid situations in which a malfunction or failure of a TOSHIBA product could cause loss of human life, bodily injury or damage to property. In developing your designs, please ensure that TOSHIBA products are used within specified operating ranges as set forth in the most recent products specifications. Also, please keep in mind the precautions and conditions set forth in the TOSHIBA Semiconductor Reliability Handbook.
- The products described in this document are subject to the foreign exchange and foreign trade laws.
- The information contained herein is presented only as a guide for the applications of our products. No responsibility is assumed by TOSHIBA CORPORATION for any infringements of intellectual property or other rights of the third parties which may result from its use. No license is granted by implication or otherwise under any intellectual property or other rights of TOSHIBA CORPORATION or others.
- The information contained herein is subject to change without notice.

BLOCK DIAGRAM

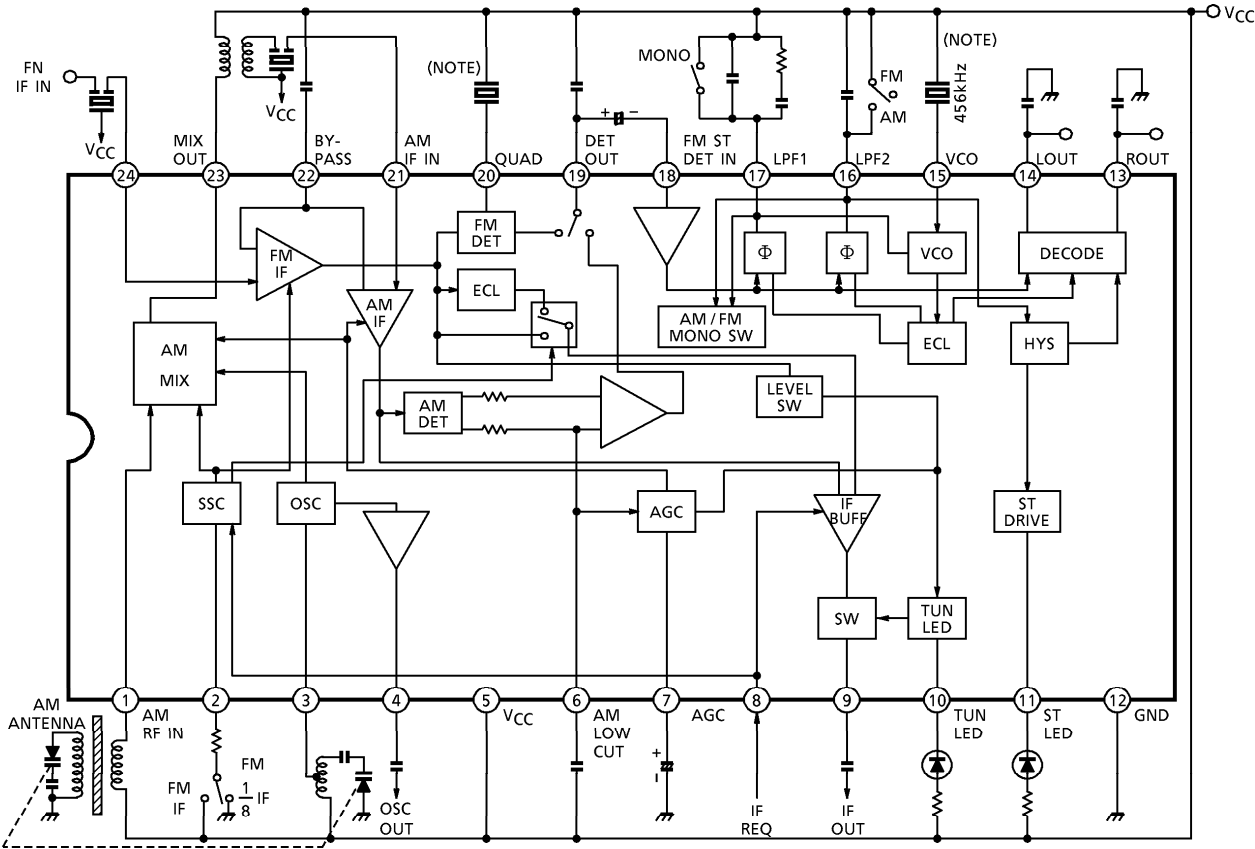

(Note)

We recommend

Ceramic resonator : CSB456F18

Ceramic discriminator : CDA10.7MG18 (MURATA MFG CO., LTD)

EXPLANATION OF TERMINALS

PIN No.	ITEM	INTERNAL CIRCUIT	DC VOLTAGE (V) (at no signal)	
			AM	FM
1	AM RF IN		3.0	3.0
2	<ul style="list-style-type: none"> • IF Count Output Sensitivity Adjust Terminal • FM IF Divider Control Terminal 		—	—
3	AM OSC		3.0	3.0
4	AM OSC OUT		2.7	3.0
5	V _{CC}	—	3.0	3.0
6	AM LOW CUT		2.3	2.3

PIN No.	ITEM	INTERNAL CIRCUIT	DC VOLTAGE (V) (at no signal)	
			AM	FM
7	AGC		0.25	0.35
8	IF OUT SW		—	—
9	IF OUT		3.0	3.0
10	TUN LED (Tuning LED)		—	—
11	ST LED (Stereo LED)		—	—
12	GND	—	0	0
13 14	R-OUT L-OUT		1.0	1.0

PIN No.	ITEM	INTERNAL CIRCUIT	DC VOLTAGE (V) (at no signal)	
			AM	FM
15	VCO		2.5	2.5 (VCO Stop mode)
16	LPF2 ● LPF Terminal for Synchronous Detector ● Bias Terminal for AM/FM Switch Circuit $V_{16} = V_{CC} \rightarrow \text{AM}$ $V_{16} = \text{open} \rightarrow \text{FM}$		3.0	2.2
17	LPF1 ● LPF Terminal for Phase Detector ● VCO Stop Terminal $V_{17} = V_{CC} \rightarrow \text{VCO Stop}$		2.7	2.2
18	FM ST DET IN		0.7	0.7
19	DET OUT		1.1	1.1

PIN No.	ITEM	INTERNAL CIRCUIT	DC VOLTAGE (V) (at no signal)	
			AM	FM
20	QUAD (FM QUAD. Detector)		2.4	2.1
21	AM IF IN		3.0	3.0
22	BY-PASS (AM IF AMP BY-PASS FM IF AMP BY-PASS)		2.3	2.8
23	AM MIX OUT		3.0	3.0
24	FM IF IN		3.0	3.0

ELECTRICAL CHARACTERISTICS

Unless otherwise specified, Ta = 25°C, V_{CC1} = 3V, SW₁→10kΩ, SW₃→OFF
 FM IF : f = 10.7MHz, Δf = ±22.5kHz, f_m = 1kHz
 AM : f = 1MHz, MOD = 30%, f_m = 1kHz
 MPX : f_m = 1kHz

CHARACTERISTIC		SYMBOL	TEST CIR-CUIT	TEST CONDITION	MIN.	TYP.	MAX.	UNIT	
Supply Current		I _{CC} (FM)	1	FM Mode, V _{in} = 0	—	11.0	14.0	mA	
		I _{CC} (AM)	1	AM Mode, V _{in} = 0	—	10.5	13.5		
FM IF	Input Limiting Voltage	V _{in} (lim.)	1	-3dB Limiting Point	41	46	51	dB μ V EMF	
	Recovered Output Voltage	V _{OD}	1	V _{in} = 80dB μ V EMF	50	75	100	mV _{rms}	
	Signal to Noise Ratio	S/N	1	V _{in} = 80dB μ V EMF	—	65	—	dB	
	Total Harmonic Distortion	THD	1	V _{in} = 80dB μ V EMF	—	0.2	—	%	
	AM Rejection Ratio	AMR	1	V _{in} = 80dB μ V EMF	—	38	—	dB	
	LED ON Sensitivity	V _L	1	I _L = 1mA	48	53	58	dB μ V EMF	
	IF Count Output Frequency	IF	f _{IF} (FM)	1	V _{in} = 80dB μ V EMF, SW ₂ →V _{CC} , SW ₃ →ON	—	10.7	—	MHz
		1/8 IF	f _{1/8 IF} (FM)	1	V _{in} = 80dB μ V EMF, SW ₂ →GND, SW ₃ →ON	1.3374	1.3375	1.3376	
	IF Count Output Voltage	IF	V _{IF} (FM)	1	V _{in} = 61dB μ V EMF, SW ₂ →V _{CC} , SW ₃ →ON	350	500	—	mV _{p-p}
		1/8 IF	V _{1/8 IF} (FM)	1	V _{in} = 61dB μ V EMF, SW ₂ →GND, SW ₃ →ON	350	500	—	
IF Count Output Sensitivity		IF _{sens.} (FM)	1	SW ₁ →0, SW ₂ →GND, SW ₃ →ON	—	76	—	dB μ V EMF	
				SW ₁ →510Ω, SW ₂ →GND, SW ₃ →ON	—	68	—		
				SW ₁ →0, SW ₂ →V _{CC} , SW ₃ →ON	—	77	—		
				SW ₁ →510Ω, SW ₂ →V _{CC} , SW ₃ →ON	—	69	—		

CHARACTERISTIC		SYMBOL	TEST CIR-CUIT	TEST CONDITION	MIN.	TYP.	MAX.	UNIT
AM	Gain	G _V	1	V _{in} = 26dB μ V EMF	28	57	85	mV _{rms}
	Recovered Output Voltage	V _{OD}	1	V _{in} = 60dB μ V EMF	50	75	100	
	Signal to Noise Ratio	S / N	1	V _{in} = 60dB μ V EMF	—	41	—	dB
	Total Harmonic Distortion	THD	1	V _{in} = 60dB μ V EMF	—	1.0	—	%
	LED ON Sensitivity	V _L	1	I _L = 1mA	21	26	31	dB μ V EMF
	Local OSC Buff. Output Voltage	V _{OSC} (AM)	1	f _{OSC} = 1.45MHz	350	500	—	mV _{p-p}
			2	f _{OSC} = 27MHz	—	500	—	
	IF Count Output Voltage	V _{IF} (AM)	1	V _{in} = 39dB μ V EMF, SW ₃ →ON	350	500	—	mV _{p-p}
IF Count Output Sensitivity	IF _{sens.} (AM)	1	SW ₁ →0, SW ₂ →GND, SW ₃ →ON	—	49	—	dB μ V EMF	
			SW ₁ →510 Ω , SW ₂ →GND, SW ₃ →ON	—	42	—		
			SW ₁ →0, SW ₂ →V _{CC} , SW ₃ →ON	—	49	—		
			SW ₁ →510 Ω , SW ₂ →V _{CC} , SW ₃ →ON	—	42	—		
Pin ^① Output Resistance	R ₁₉	1	FM Mode	—	0.6	—	k Ω	
			AM Mode	—	12	—		

CHARACTERISTIC		SYMBOL	TEST CIR-CUIT	TEST CONDITION	MIN.	TYP.	MAX.	UNIT	
MPX	Input Resistance	R _{IN}	1	—	—	25	—	kΩ	
	Output Resistance	R _{OUT}	1	—	—	5	—		
	Max. Composite Signal Input Voltage	V _{in} MAX (Stereo)	1	L + R = 90%, P = 10% THD = 3%, SW _g →LPF : ON	—	350	—	mV _{rms}	
	Separation	Sep	—	L + R = 135mV _{rms} , P = 15mV _{rms} , SW _g →LPF : ON	f _m = 100Hz	—	42	—	dB
					f _m = 1kHz	35	42	—	
					f _m = 10kHz	—	42	—	
	Total Harmonic Distortion	Monaural	THD (Monaural)	1	V _{in} = 150mV _{rms} (MONO)	—	0.2	—	%
		Stereo	THD (Stereo)		L + R = 135mV _{rms} , P = 15mV _{rms} SW _g →LPF : ON	—	0.2	—	
	Voltage Gain		G _V (MPX)	1	V _{in} = 150mV _{rms} (MONO)	-5	-3	-1	dB
	Channel Balance		C.B.	1	V _{in} = 150mV _{rms} (MONO)	-2	0	2	dB
	Stereo LED Sensitivity	ON	V _L (ON)	1	Pilot Input	—	8	15	mV _{rms}
		OFF	V _L (OFF)			2	6	—	
	Stereo LED Hysteresis		V _H	1	To LED turn off from LED turn on	—	2	—	mV _{rms}
Capture Range		C.R.	1	P = 15mV _{rms}	—	± 1.3	—	%	
Signal to Noise Ratio		S/N	1	V _{in} = 150mV _{rms} (MONO)	—	78	—	dB	

TEST CIRCUIT 1

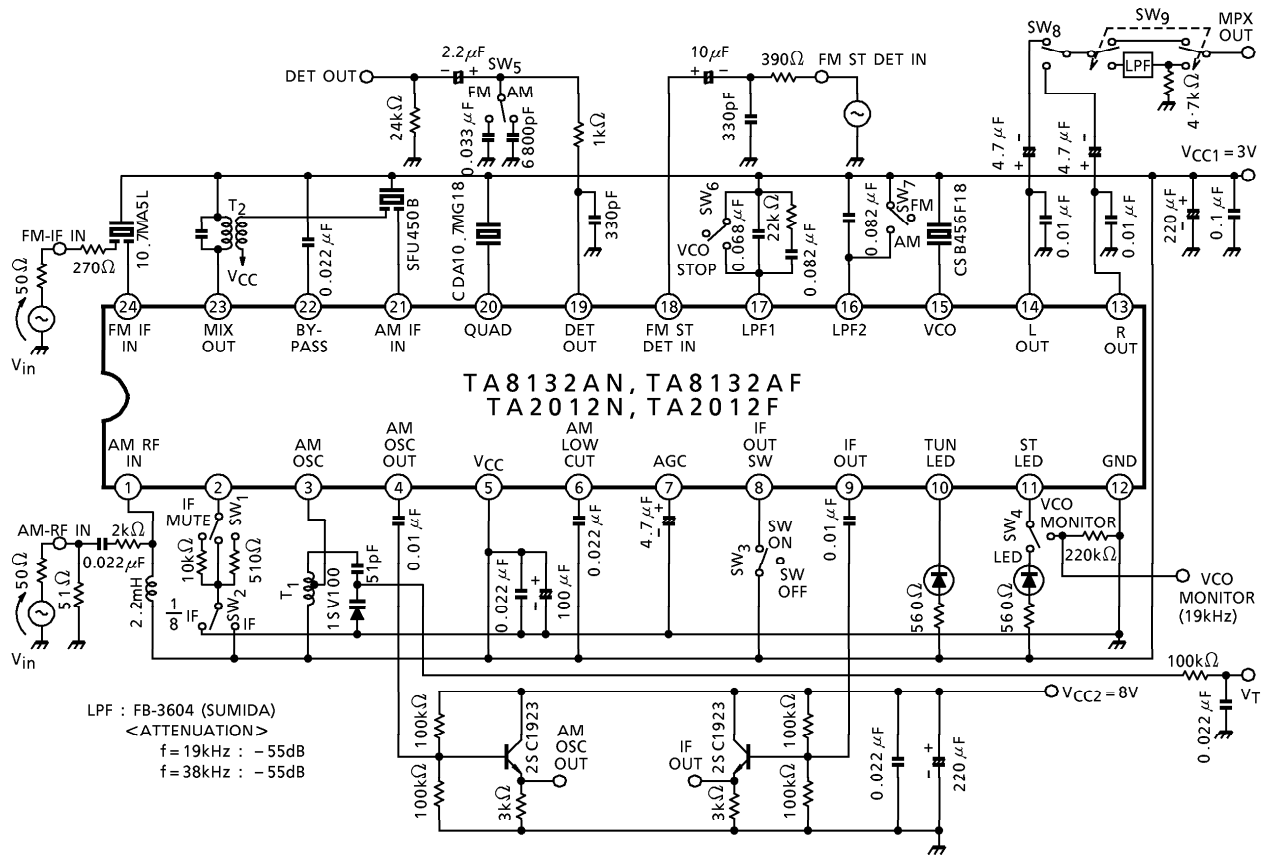

COIL DATA (TEST CIRCUIT 1)

COIL No.	f	L (μH)	C ₀ (pF)	Q ₀	TURN				WIRE (mm)	RED. (COIL No.)
					1-2	2-3	1-3	4-6		
T ₁ AM OSC	796kHz	288	—	115	13	73	—	—	0.08 UEW	4147-1356-038 Ⓢ
T ₂ AM IFT	455kHz	—	180	120	—	—	180	15	0.06 UEW	2150-2162-165 Ⓢ

Ⓢ : SUMIDA ELECTRIC Co., Ltd.

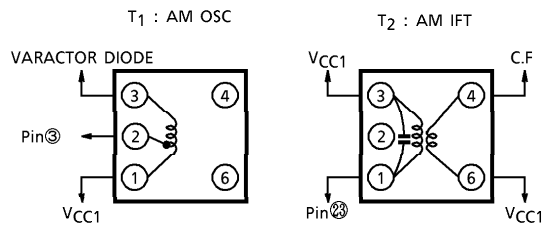

TEST CIRCUIT 2

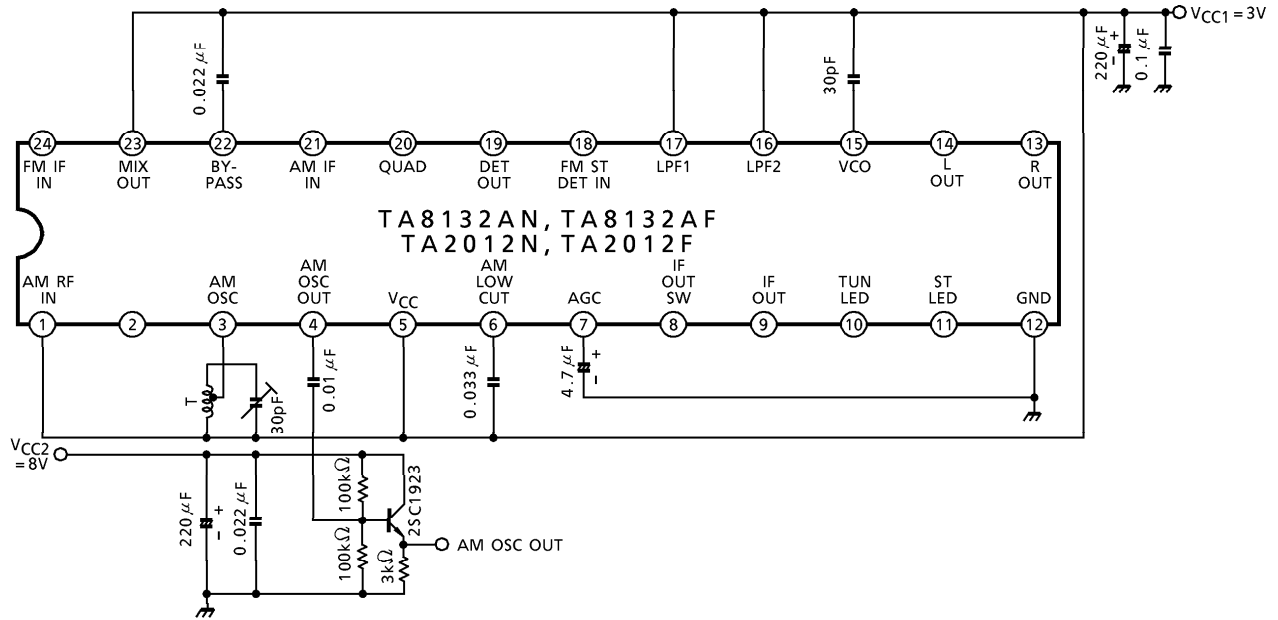

COIL DATA (TEST CIRCUIT 2)

COIL No.	f	L (μ H)	C ₀ (pF)	Q ₀	TURN				WIRE (mm)	REF. (COIL No.)
					1-2	2-3	1-3	4-6		
T AM OSC	7.96MHz	1.4	—	84	1	6	7	—	0.08 UEW	Ⓣ 7PL-1344Y

Ⓣ : TOKO Co., Ltd.

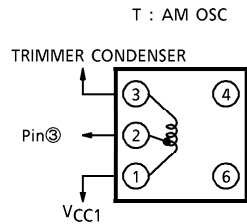

PACKAGE DIMENSIONS
SDIP24-P-300-1.78

Unit : mm

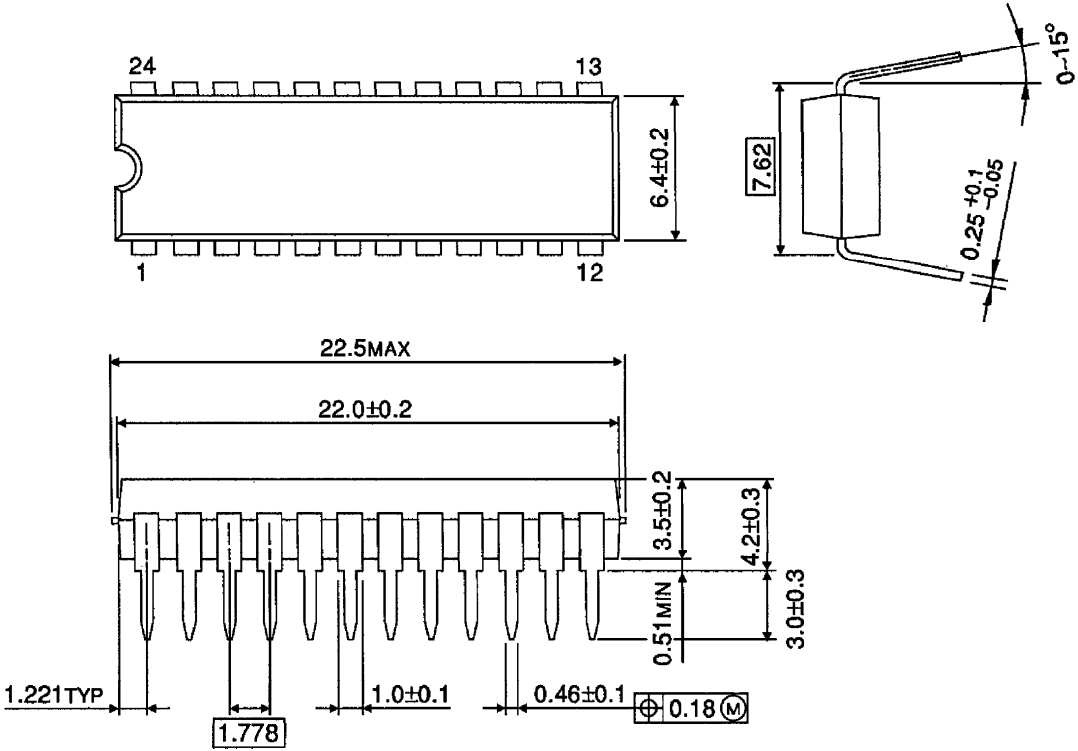

Weight : 1.2g (Typ.)

PACKAGE DIMENSIONS
SSOP24-P-300-1.00

Unit : mm

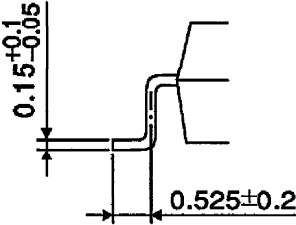
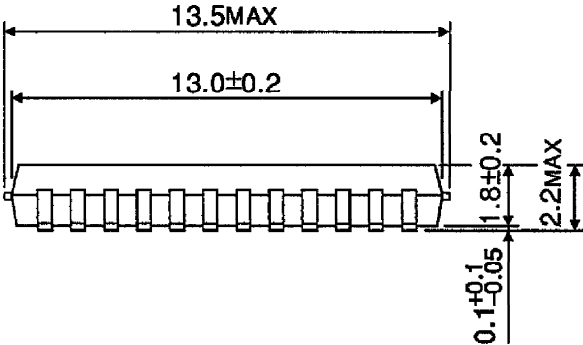
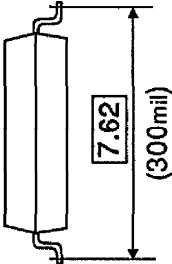
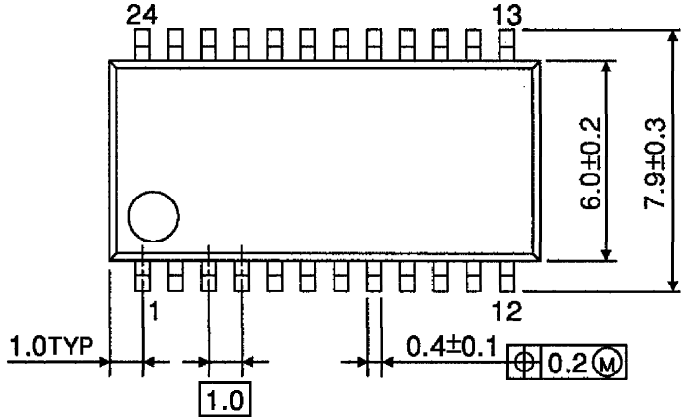

Weight : 0.31g (Typ.)