

TOSHIBA BIPOLAR LINEAR INTEGRATED CIRCUIT SILICON MONOLITHIC

# TA8184P, TA8184F

## DUAL CHANNEL VOLTAGE / TONE CONTROL IC

The TA8184P, TA8184F is DC controlled dual volume, balance, tone (Bass and treble) IC.

It is suitable for car stereo, radio cassette, music center, TV multiplex sound receiver and remote controlled applications.

### FEATURES

- Dual Channel
- Wide Volume Control Range  
: Maximum Attenuation ATT = 100dB (Typ.)  
(Vol. → MIN.,  $V_{IN} = 1V_{rms}$ , BW = 400Hz~30kHz)
- Wide Tone Control Range  
: Bass  $V_B = +12.5 \sim -12.5$ dB (Typ.), (f = 100Hz)  
: Treble  $V_T = +12.5 \sim -12.5$ dB (Typ.), (f = 10kHz)
- Built In Loudness Control
- Operating Supply Voltage Range  
:  $V_{CC} (opr) = 7.5 \sim 15$ V (TA8184P) ( $T_a = 25^\circ\text{C}$ )  
:  $V_{CC} (opr) = 7.5 \sim 12.5$ V (TA8184F) ( $T_a = 25^\circ\text{C}$ )

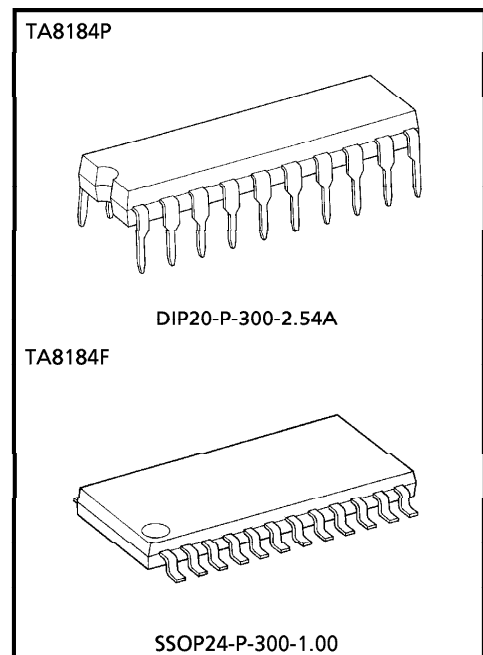

### Weight

DIP20-P-300-2.54A : 1.4g (Typ.)  
SSOP24-P-300-1.00 : 0.31g (Typ.)

961001EBA2

- TOSHIBA is continually working to improve the quality and the reliability of its products. Nevertheless, semiconductor devices in general can malfunction or fail due to their inherent electrical sensitivity and vulnerability to physical stress. It is the responsibility of the buyer, when utilizing TOSHIBA products, to observe standards of safety, and to avoid situations in which a malfunction or failure of a TOSHIBA product could cause loss of human life, bodily injury or damage to property. In developing your designs, please ensure that TOSHIBA products are used within specified operating ranges as set forth in the most recent products specifications. Also, please keep in mind the precautions and conditions set forth in the TOSHIBA Semiconductor Reliability Handbook.
- The products described in this document are subject to foreign exchange and foreign trade control laws.
- The information contained herein is presented only as a guide for the applications of our products. No responsibility is assumed by TOSHIBA CORPORATION for any infringements of intellectual property or other rights of the third parties which may result from its use. No license is granted by implication or otherwise under any intellectual property or other rights of TOSHIBA CORPORATION or others.
- The information contained herein is subject to change without notice.

BLOCK DIAGRAM

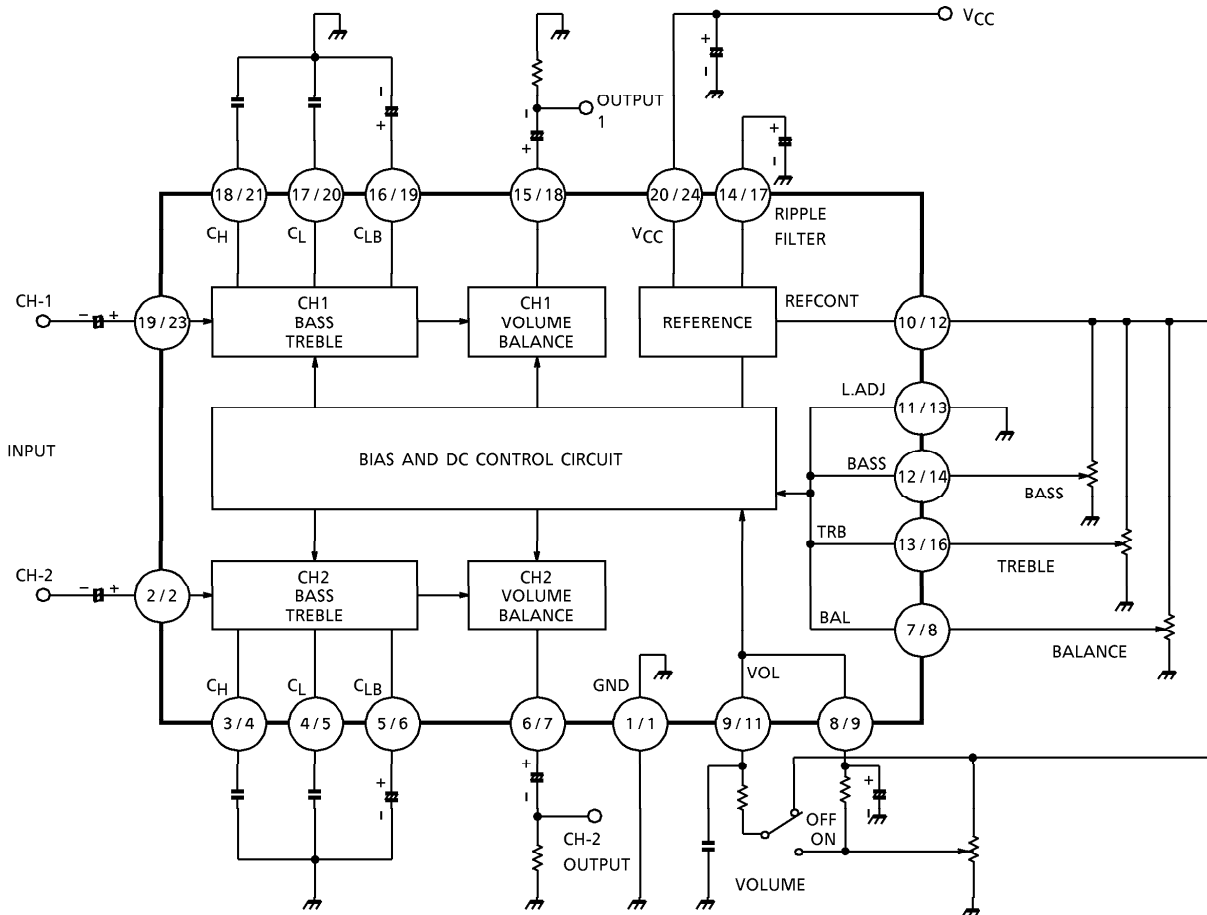

PIN CONNECTION : 

TA8184F : pin ③, ⑩, ⑮, ⑳ : N.C

PIN CONNECTION (TA8184P)

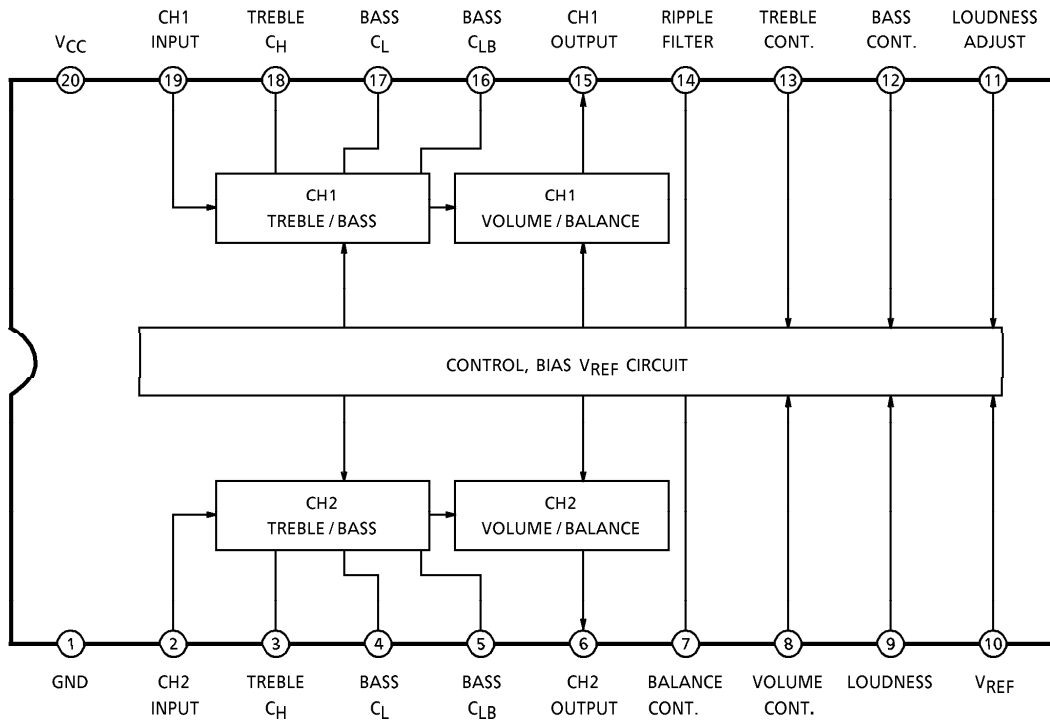

PIN FUNCTION

PIN No.	SYMBOL	EXPLANATION	PIN No.	SYMBOL	EXPLANATION
1	GND	GND	11	L.ADJ.	LOUDNESS ADJUST
2	IN2	CH2, INPUT	12	BASS	BASS CONTROL
3	C <sub>H</sub> (2)	CH2, TREBLE CONTROL TIME CONSTANT	13	TRBL	TREBLE CONTROL
4	C <sub>L</sub> (2)	CH2, BASS CONTROL TIME CONSTANT	14	RIP	RIPPLE FILTER
5	C <sub>LB</sub> (2)	CH2, BASS CONTROL TIME CONSTANT	15	OUT1	CH1, OUTPUT
6	OUT2	CH2, OUTPUT	16	C <sub>LB</sub> (1)	CH1, BASS CONTROL TIME CONSTANT
7	BAL	BALANCE CONTROL	17	C <sub>L</sub> (1)	CH1, BASS CONTROL TIME CONSTANT
8	VOL	VOLUME CONTROL	18	C <sub>H</sub> (1)	CH1, TREBLE CONTROL TIME CONSTANT
9	LOUD	LOUDNESS SWITCH	19	IN1	CH1, INPUT
10	REF	REFERENCE	20	V <sub>CC</sub>	V <sub>CC</sub>

PIN CONNECTION (TA8184F)

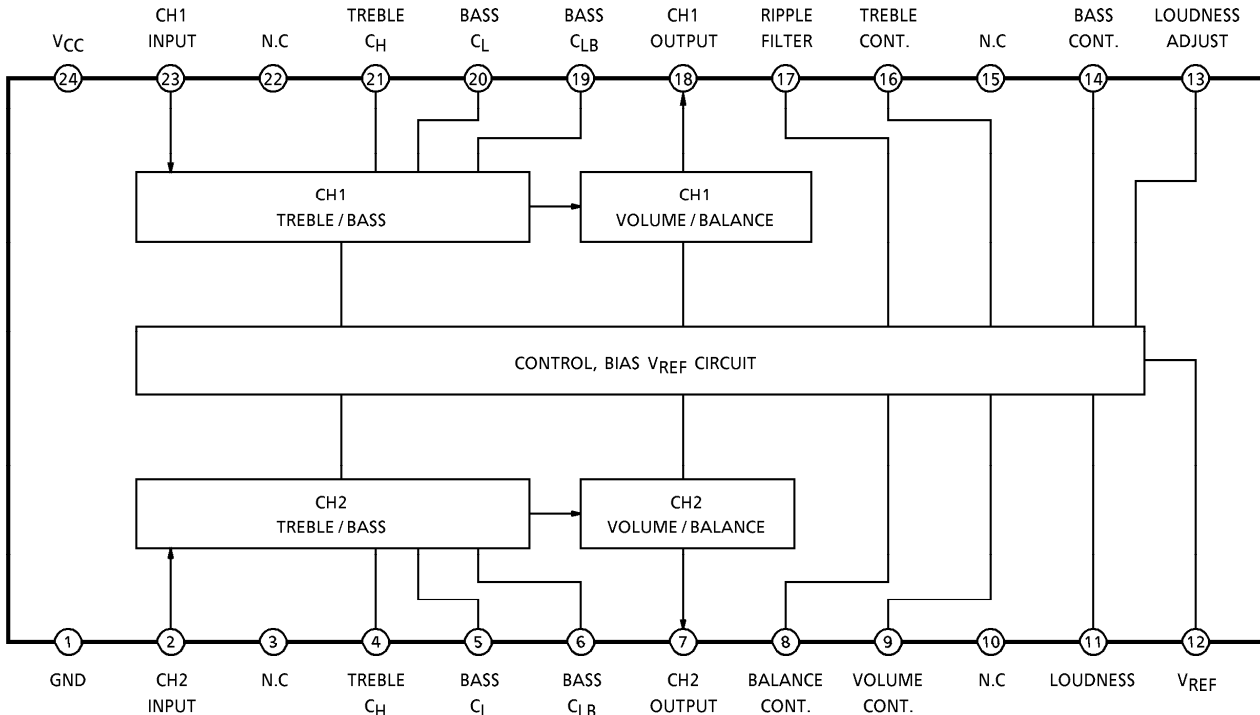

PIN FUNCTION

PIN No.	SYMBOL	EXPLANATION	PIN No.	SYMBOL	EXPLANATION
1	GND	GND	13	L.ADJ.	LOUDNESS ADJUST
2	IN2	CH2, INPUT	14	BASS	BASS CONTROL
3	N.C		15	N.C	
4	CH (2)	CH2, TREBLE CONTROL TIME CONSTANT	16	TRBL	TREBLE CONTROL
5	CL (2)	CH2, BASS CONTROL TIME CONSTANT	17	RIP	RIPPLE FILTER
6	CLB (2)	CH2, BASS CONTROL TIME CONSTANT	18	OUT1	CH1, OUTPUT
7	OUT2	CH2, OUTPUT	19	CLB (1)	CH1, BASS CONTROL TIME CONSTANT
8	BAL	BALANCE CONTROL	20	CL (1)	CH1, BASS CONTROL TIME CONSTANT
9	VOL	VOLUME CONTROL	21	CH (1)	CH1, TREBLE CONTROL TIME CONSTANT
10	N.C		22	N.C	
11	LOUD	LOUDNESS SWITCH	23	IN1	CH1, INPUT
12	REF	REFERENCE	24	VCC	VCC

**OPERATING PRECAUTIONS AND APPLICATION METHODS (Pin No. : (P/F))**

(1) How to Determine Tone Controlled Frequency Characteristic Time Constants

Bass characteristics determining elements :  $C_L$ ,  $C_{LB}$  terminals (4/5), (5/6), (16/19), (17/20)

Fig.1 Low-bandwidth cut-off frequencies  $f_{L1}$ ,  $f_{L2}$ ,  $f_{L3}$  of bass characteristics are determined by the following equations :

$$f_{L1} = \frac{1}{2\pi \cdot C_{LB} \cdot 10k\Omega} \dots\dots (1)$$

(10kΩ is determined in IC interior)

$$f_{L2} = \frac{1}{2\pi \cdot C_{LB} \cdot 1k\Omega} \dots\dots (2)$$

(1kΩ is determined in IC interior)

$$f_{L3} = \frac{1}{2\pi \cdot C_L \cdot 10k\Omega} \dots\dots (3)$$

(10kΩ is determined in IC interior)

Under reference circuits of  $C_L = 0.33\mu F$  and  $C_{LB} = 10\mu F$ , setting is made as follows :

$$f_{L1} \doteq 1.59\text{Hz}, f_{L2} \doteq 15.9\text{Hz}, f_{L3} \doteq 48.2\text{Hz}$$

When the characteristics during boosting are considered, crossing with 0dB axis is made at  $f_{L1}$ , increase starts by 20dB/dec., and flat characteristics of Gain = 20dB is obtained at  $f_{L2}$ .

Low-bandwidth f response is determined at  $f_{L3}$ -namely,  $C_L$  and gain starts decreasing from  $f_{L3}$  by -20dB/dec.

As explained above, low-bandwidth characteristics can be varied by varying  $C_L$  and  $C_{LB}$ .

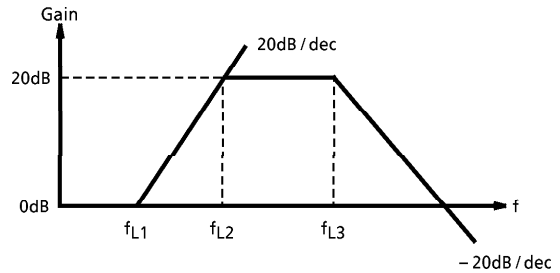

Fig.1 Bass characteristics (during boosting)

Treble characteristics determining element :  $C_H$  (3/4), (18/21)

Fig.2 High-bandwidth cut-off frequencies  $f_{H1}$  and  $f_{H2}$  of treble characteristics can be determined by the following equations :

$$f_{H1} = \frac{1}{2\pi \cdot C_H \cdot 10k\Omega} \dots\dots (4)$$

(10kΩ is determined in IC interior)

$$f_{H2} = \frac{1}{2\pi \cdot C_H \cdot 1k\Omega} \dots\dots (5)$$

(1kΩ is determined in IC interior.)

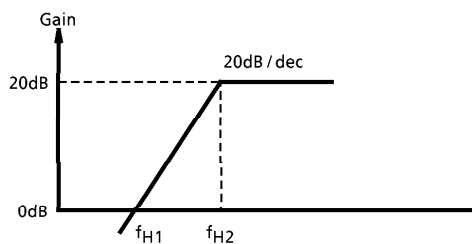

Fig.2 Treble characteristics (during boosting)

Under reference circuit of  $C_H = 0.0082\mu F$  setting is made as follows :

$$f_{H1} \doteq 1.94\text{kHz}, f_{H2} = 19.4\text{kHz}$$

As explained above, high-bandwidth characteristics can be varied by varying  $C_H$ .

By creating the status of  $C_L \rightarrow$ decrease and  $C_H \rightarrow$ increase, low/high bandwidth gains (f = 100Hz, 10kHz) increase but gain near f = 1kHz is also increased.

On the other hand, when the status of  $C_L \rightarrow$ increase and  $C_H \rightarrow$ decrease is created, take note that gain near f = 1kHz approaches 0dB while low/high-bandwidth gains are decreased.

## (2) Loudness control

By connecting pin⑨ / ⑪ (loudness terminal) to pin (8/9) (volume terminal), "Loudness" status can be created.

Loudness boost amount is determined by pin (9/11) DC voltage (refer to the subsequently described  $G_V$ -V (9/11) data).

Loudness is controlled by considering that sound levels will become uniform for all frequency levels through increasing low / high-bandwidth gains when volume is reduced-namely, sound volume is low.

When loudness control is not used, connect pin (9/11) to pin (10/12) (reference terminal).

The capacitor (Typ.  $0.047\mu\text{F}$ ) between pin (9/11) and GND is for reducing pop sound during loudness→ON while the capacitor (Typ.  $1\mu\text{F}$ ) between pin (8/9) and GND is used for the same purpose during loudness→OFF.

## (3) Loudness adjustment

When loudness is set, the boost amount can be varied by adjusting voltage at pin⑪ / ⑬. Under  $V(11/13) = 0\text{V}$ , maximum boost amount is obtained and under  $V(11/13) = V_{\text{REF}}$  (connected to pin⑩ / ⑫), minimum boost amount is obtained (refer to the subsequently described  $G_V$ -V (11/13) data).

## (4) Relations between tone control and loudness

Because of the circuit configuration on this IC, the sum of boost amount by bass/treble control and boost amount by loudness setting is restricted to become below a constant value. Therefore, the greater the boost amount in-creases, the lower the boost amount by bass/treble control is reduced because loudness is extensively applied. As opposed to this phenomenon, on the other hand, the cut amount increases. (Refer to the subsequent descriptions on tone control frequency response during loudness.)

MAXIMUM RATINGS ( $T_a = 25^\circ\text{C}$ )

CHARACTERISTIC		SYMBOL	RATING	UNIT
Power Supply Voltage	TA8184P	$V_{\text{CC}}$	15	V
	TA8184F		12.5	
Power Dissipation	TA8184P	$P_{\text{D}}$ (Note 1)	1200	mW
	TA8184F		750 (Note 2)	
Operating Temperature		$T_{\text{opr}}$	- 30~85	$^\circ\text{C}$
Storage Temperature		$T_{\text{stg}}$	- 55~150	$^\circ\text{C}$

(Note 1) Derated above  $T_a = 25^\circ\text{C}$  in the proportion of  $9.6\text{mW}/^\circ\text{C}$  for TA8184P, and of  $6.0\text{mW}/^\circ\text{C}$  for TA8184F.

(Note 2) Value for mounting on PC board (60mm×85mm×1.2mm, Glass epoxy.)

**ELECTRICAL CHARACTERISTICS** (Unless otherwise specified,  $V_{CC} = 8V$ ,  $f = 1kHz$ ,  $T_a = 25^\circ C$ )

CHARACTERISTIC	SYMBOL	TEST CIR-CUIT	TEST CONDITION		MIN.	TYP.	MAX.	UNIT
Quiescent Current	$I_{CCQ}$	—	$V_{IN} = 0$		—	19	27	mA
Voltage Reference	$V_{ref}$	—	—		4.7	5.1	5.5	V
Maximum Output Voltage	$V_{OM}$	—	TONE / BAL = CENTER VOL = MAX., THD = 1%		1.2	1.6	—	$V_{rms}$
Voltage Gain	$G_V$	—	TONE / BAL = CENTER VOL = MAX., $V_{IN} = 0.1V_{rms}$		-2.0	0	2.0	dB
Maximum Attenuation	ATT	—	TONE / BAL = CENTER BW = 400Hz~30kHz VOL = MIN., $V_{IN} = 1V_{rms}$		85	100	—	dB
Bass Control Range	$V_B$ MAX	—	TONE = MAX.	VOL = MAX. BAL = CENTER	9.5	12.5	15.5	dB
	$V_B$ MIN	—	TONE = MIN.	$f_{IN} = 1kHz \rightarrow 100Hz$ $V_{IN} = 0.1V_{rms}$	-15.5	-12.5	-9.5	
Treble Control Range	$V_T$ MAX	—	TONE = MAX.	VOL = MAX. BAL = CENTER	9.0	12.5	16.0	dB
	$V_T$ MIN	—	TONE = MIN.	$f_{IN} = 1kHz \rightarrow 10kHz$ $V_{IN} = 0.1V_{rms}$	-16.0	-12.5	-9.0	
Total Harmonic Distortion	THD	—	TONE / BAL = CENTER, $f = 1kHz$ , VOL = MAX., $V_{IN} = 1V_{rms}$		—	0.05	0.2	%
Output Noise Voltage	$V_{NO}$	—	TONE / BAL = CENTER BW = 20Hz~20kHz VOL = MIN., input open		—	4	10	$\mu V_{rms}$
Loudness Control	$V_{LB}$	—	$f = 100Hz$	TONE / BAL = CENTER LOUDNESS = ON $V_{IN} = 1V_{rms}$ VOL = SW <sub>1</sub> ( 4 )	8	11	14	dB
	$V_{LT}$	—	$f = 10kHz$	LOUDNESS TEST = SW <sub>5</sub> ( 2 )	8	11	14	

TEST CIRCUIT

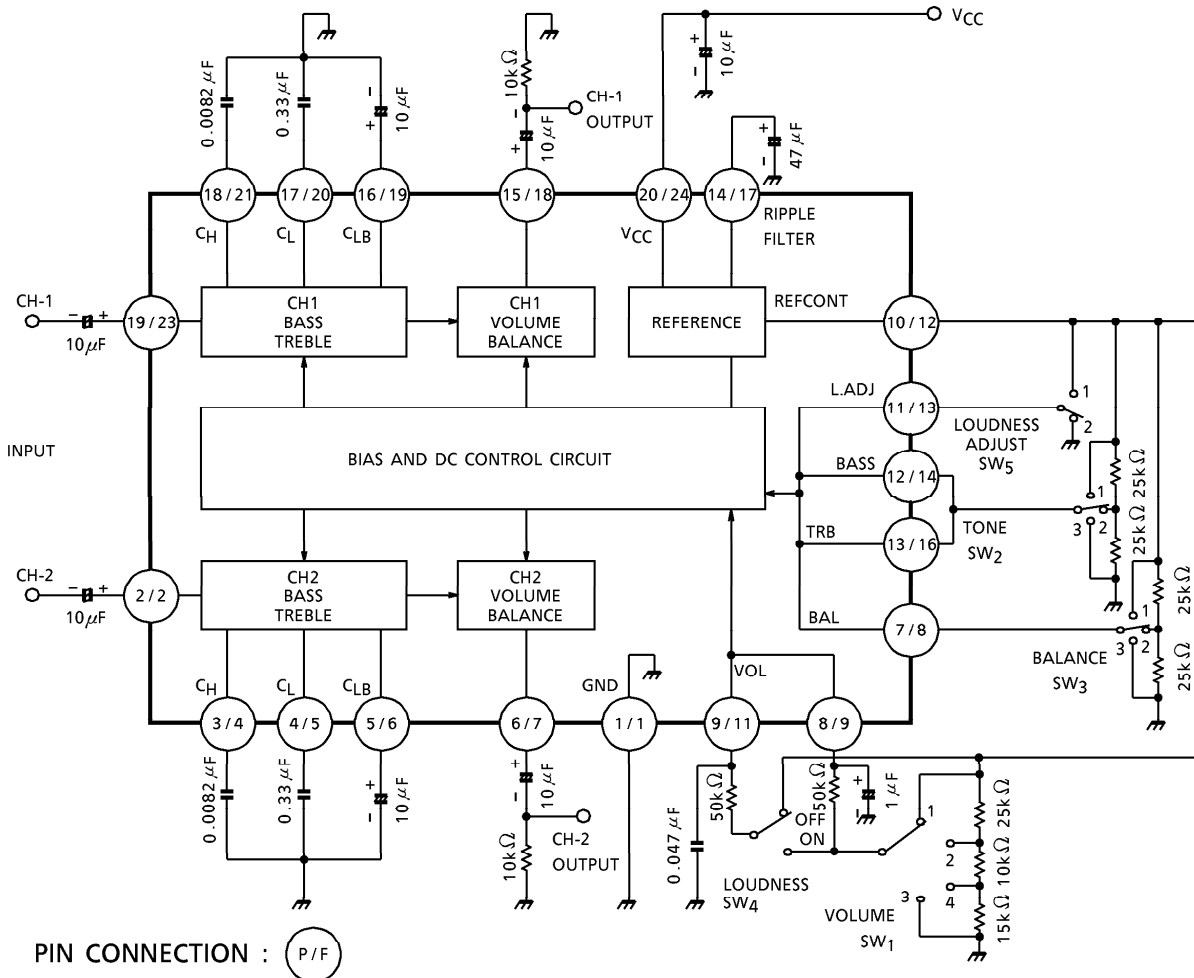

PIN CONNECTION : P/F

TA8184F : pin ③, ⑩, ⑮, ⑳ : N.C

SWITCH EXPLANATION

SWITCH NAME	POSITION					ON	OFF
	1	2	3	4			
SW <sub>1</sub> : VOLUME	MAX.	CENTER	MIN.	LOUDNESS TEST	—	—	
SW <sub>2</sub> : TONE	MAX.	CENTER	MIN.	—	—	—	
SW <sub>3</sub> : BALANCE	CH2 CUT	CENTER	CH1 CUT	—	—	—	
SW <sub>4</sub> : LOUDNESS	—	—	—	—	LOUDNESS ON	LOUDNESS OFF	
SW <sub>5</sub> : LOUDNESS ADJUST	MIN.	MAX.	—	—	—	—	



OUTLINE DRAWING  
DIP20-P-300-2.54A

Unit : mm

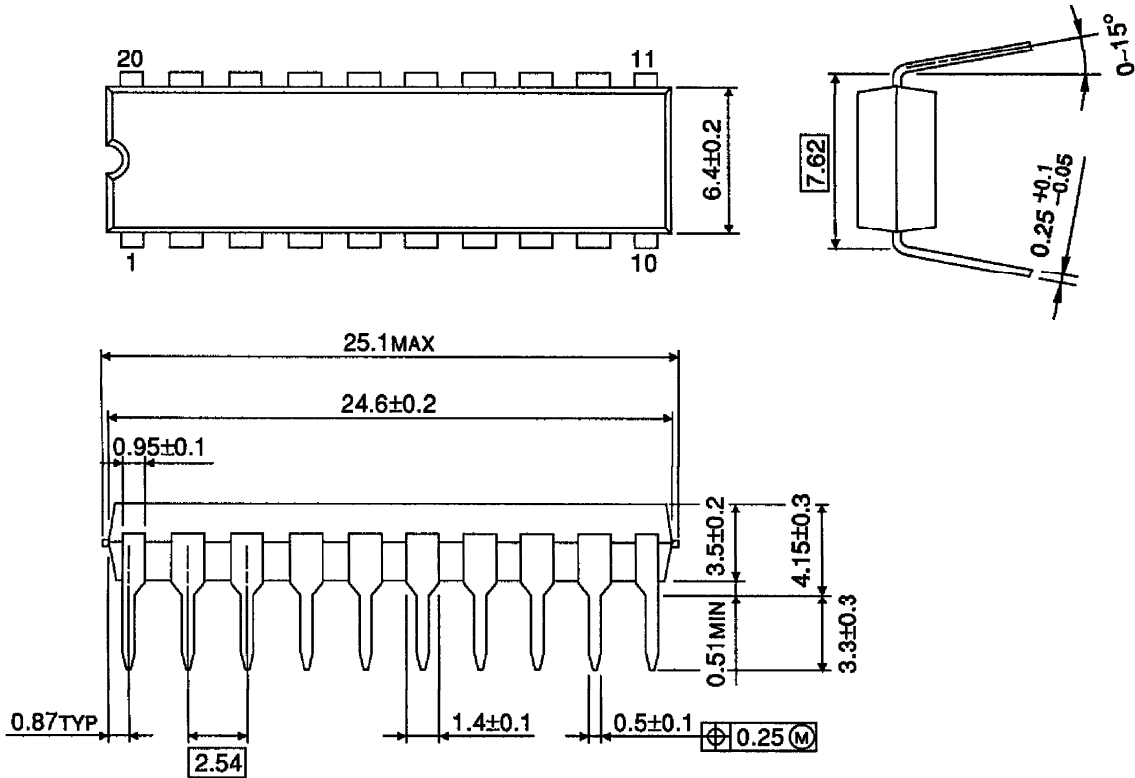

Weight : 1.4g (Typ.)

OUTLINE DRAWING  
SSOP24-P-300-1.00

Unit : mm

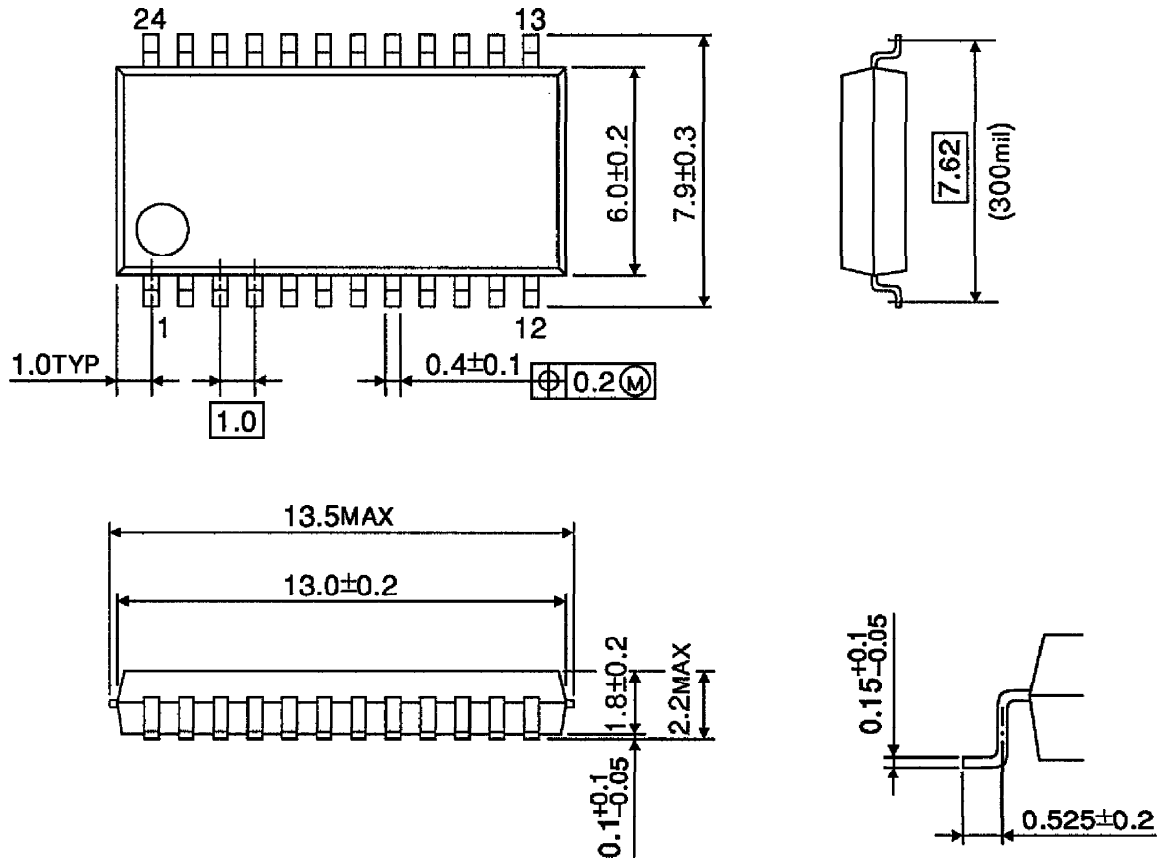

Weight : 0.31g (Typ.)