

TOSHIBA BIPOLAR LINEAR INTEGRATED CIRCUIT SILICON MONOLITHIC

TA8190F, TA8191F

CD FOCUS TRACKING SERVO LSI

The TA8190F, TA8191F is a 3-beam type PUH compatible focus tracking servo LSIs to be used in the CD player system.

In combination with a CMOS single chip processor TC9236AF, a CD player system can be composed very simply.

FEATURES

- Built-in RF amp, focus error amp, and tracking error amp.
- Built-in focus tracking servo amp.
- Built-in phase compensation amp and LPF amp. (Regarding these amp, the pin connection differs between the TA8190F and the TA8191F.)
- Built-in ALPC amp.
- Connections between PUH and power driver IC for motor driver allow simplified structuring of CD player system.

TA8190F : Directly connectable to a transistor push-pull or power driver (TA8212F).

TA8191F : Directly connectable to BTL amp (TA8192F) or PWM driver (TA8460F).

- Differences between TA8190F and TA8191F are as follows :

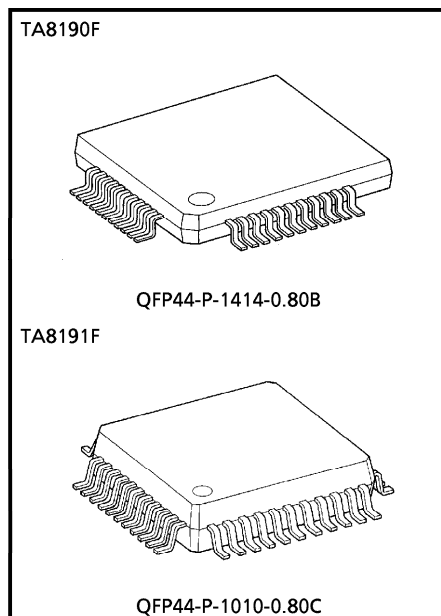

Weight
 QFP44-P-1414-0.80B : 1.15g (Typ.)
 QFP44-P-1010-0.80C : 0.5g (Typ.)

MODEL	REFERENCE VOLTAGE TERMINAL		PACKAGE (FLAT PACKAGE 44 PIN)	POWER SUPPLY	APPLICATION
	V _{REF}	2V _{REF}			
TA8190F	Yes	No	QFP44-P-1414B	± 5V double power supply	CD player
TA8191F	Yes	Yes	QFP44-P-1010C	+ 5V single power supply	Portable CD player Radio-cassette CD player

(V_{REF} = 2.1V, 2V_{REF} = 4.2V)

980508EBA2

● TOSHIBA is continually working to improve the quality and the reliability of its products. Nevertheless, semiconductor devices in general can malfunction or fail due to their inherent electrical sensitivity and vulnerability to physical stress. It is the responsibility of the buyer, when utilizing TOSHIBA products, to observe standards of safety, and to avoid situations in which a malfunction or failure of a TOSHIBA product could cause loss of human life, bodily injury or damage to property. In developing your designs, please ensure that TOSHIBA products are used within specified operating ranges as set forth in the most recent products specifications. Also, please keep in mind the precautions and conditions set forth in the TOSHIBA Semiconductor Reliability Handbook.

BLOCK DIAGRAM
TA8190F

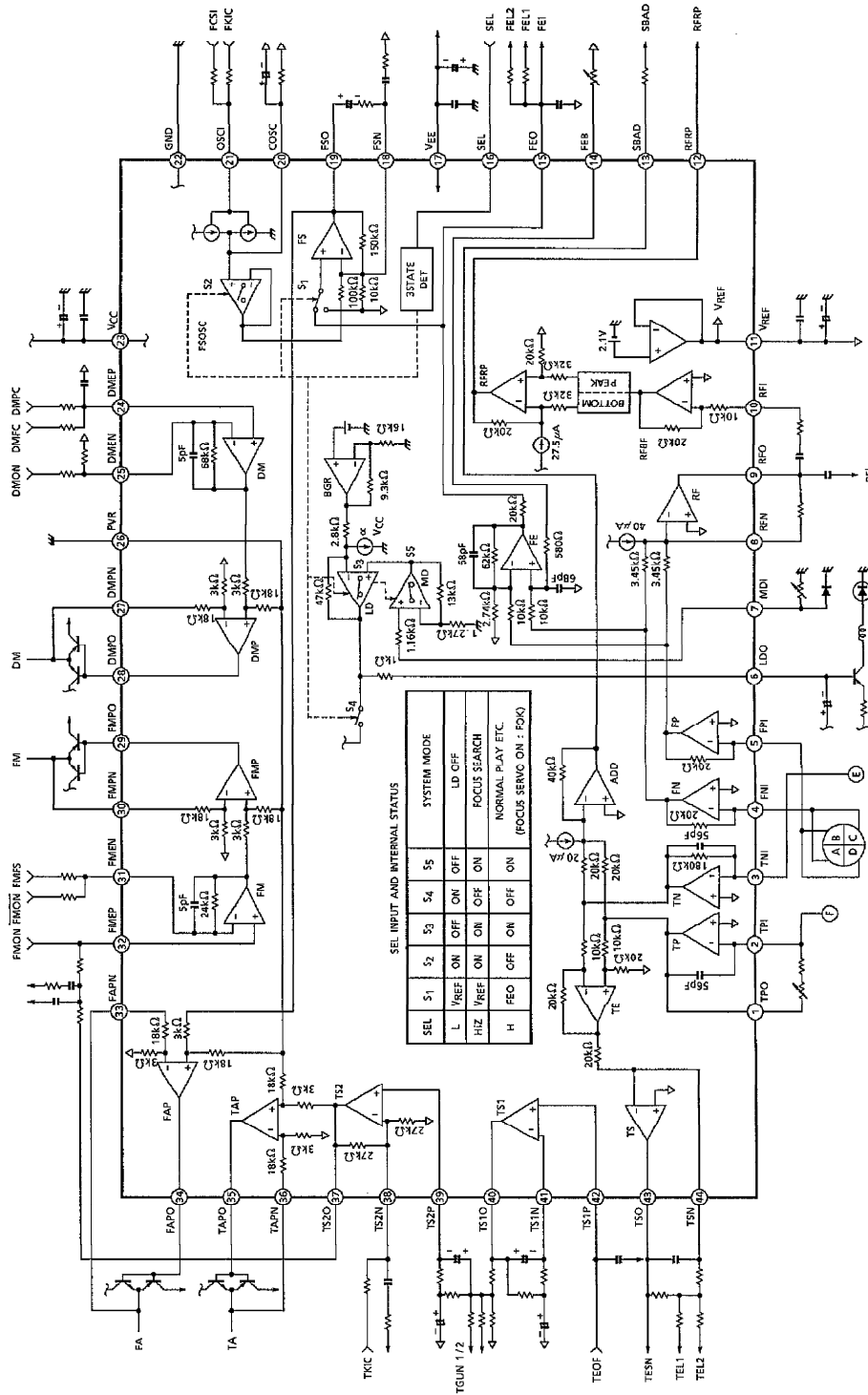

TA8190,91F-2

980508EBA2

● The products described in this document are subject to foreign exchange and foreign trade laws.
 ● The information contained herein is presented only as a guide for the applications of our products. No responsibility is assumed by TOSHIBA CORPORATION for any infringements of intellectual property or other rights of the third parties which may result from its use. No license is granted by implication or otherwise under any intellectual property or other rights of TOSHIBA CORPORATION or others.
 ● The information contained herein is subject to change without notice.

PIN FUNCTION
 (Common)

PIN No.	SYMBOL	I/O	FUNCTIONAL DESCRIPTION	REMARKS
1	TPO	O	Sub-beam I-V amp (TP AMP) output terminal.	Connected to TPI through adjusting feedback resistor.
2	TPI	I	Sub-beam I-V amp (TP AMP) input terminal.	Connected to PIN diode F.
3	TNI	I	Sub-beam I-V amp (TN AMP) input terminal.	Connected to PIN diode E.
4	FNI	I	Main-beam I-V amp (FN AMP) input terminal.	Connected to PIN diode A + C.
5	FPI	I	Main-beam I-V amp (FP AMP) input terminal.	Connected to PIN diode B + D.
6	LDO	O	Laser diode amp (LD AMP) input terminal.	Connected to laser diode circuit.
7	MDI	I	Monitor photo diode amp (MD AMP) input terminal.	Connected to monitor photo diode.
8	RFN	I	RF amp (RF AMP) negative phase input terminal.	Connected to RFO through feedback resistor.
9	RFO	O	RF amp (RF AMP) output terminal.	—
10	RFI	I	RF ripple signal generating circuit input terminal.	Connected to RFO through CR.
11	V _{REF}	O	Reference voltage supply output terminal. (+2.1V)	—
12	RFRP	O	RF ripple signal output terminal.	—
13	SBAD	O	Defects detection signal output terminal.	—
14	FEB	I	Focus error balance adjusting input terminal.	Adjusting semi-fixed resistor connected.
15	FEO	O	Focus error amp (FE AMP) output terminal.	Gain adjusting resistor is connected.
16	SEL	I	Analog switch control signal input terminal.	—
17	V _{EE}	—	Power source terminal. (TA8190F : -5V, TA8191F : GND)	—
18	FSN	I	Focus output amp (FS AMP) negative phase input terminal.	Connected to FSO through feedback CR.
19	FSO	O	Focus output amp (FS AMP) output terminal.	—
20	COSC	O	Focus search signal generating capacitor connecting terminal.	CR is connected.
21	OSCI	I	Focus search signal generating built-in current source control input terminal.	—
22	GND	—	Ground terminal.	—

(Common)

PIN No.	SYMBOL	I/O	FUNCTIONAL DESCRIPTION	REMARKS
23	V _{CC}	—	Power source terminal. (+5V)	—
24	DMEP	I	Disc motor amp (DM AMP) positive phase input terminal.	—
25	DMEN	I	Disc motor amp (DM AMP) negative phase input terminal.	—
31	FMEN	I	Feed motor amp (FM AMP) negative phase input terminal.	—
32	FMEP	I	Feed motor amp (FM AMP) positive phase input terminal.	—
37	TS2O	O	Tracking servo amp 2 (TS2 AMP) output terminal.	—
38	TS2N	I	Tracking servo amp 2 (TS2 AMP) negative phase input terminal.	—
39	TS2P	I	Tracking servo amp 2 (TS2 AMP) positive phase input terminal.	—
40	TS1O	O	Tracking servo amp 1 (TS1 AMP) output terminal.	—
41	TS1N	I	Tracking servo amp 1 (TS1 AMP) negative phase input terminal.	Connected to TS1O through feedback CR.
42	TS1P	I	Tracking servo amp 1 (TS1 AMP) positive phase input terminal.	—
43	TSO	O	Tracking output amp (TS AMP) output terminal.	—
44	TSN	I	Tracking output amp (TS AMP) negative phase input terminal.	Connected to TSO through feedback CR.

(TA8190F)

PIN No.	SYMBOL	I/O	FUNCTIONAL DESCRIPTION	REMARKS
26	PVR	I	Driving amp reference voltage input terminal.	Connect to GND.
27	DMPN	I	Disc motor driving amp (DMP AMP) negative phase input terminal.	—
28	DMPO	O	Disc motor driving amp (DMP AMP) output terminal.	Connected to DMPN through external output Tr.
29	FMPO	O	Feed motor driving amp (FMP AMP) output terminal.	Connected to EMPN through external output Tr.
30	FMPN	I	Feed motor driving amp (FMP AMP) negative phase input terminal.	—
33	FAPN	I	Focus actuator driving amp (FAP AMP) negative phase input terminal.	—
34	FAPO	O	Focus actuator driving amp (FAP AMP) output terminal.	Connected to FAPN through external output Tr.
35	TAPO	O	Tracking actuator driving amp (TAP AMP) output terminal.	Connected to TAPN through external output Tr.
36	TAPN	I	Tracking actuator driving amp (TAP AMP) negative phase input terminal.	—

(TA8191F)

PIN No.	SYMBOL	I/O	FUNCTIONAL DESCRIPTION	REMARKS
26	DMEO	O	Disc motor amp (DM AMP) output terminal.	—
27	DMPO	O	Disc motor driving amp (DM AMP) output terminal.	—
28	PVR	I	Driving amp reference voltage input terminal.	Connected to V _{REF} .
29	FMPO	O	Feed motor driving amp (FMP AMP) output terminal.	—
30	FMEO	O	Feed motor amp (FM AMP) output terminal.	—
33	FAPO	O	Focus actuator driving amp (FAP AMP) output terminal.	—
34	2VRO	O	2V _{REF} amp (2V _{REF} AMP) output terminal.	Connected to 2VRP through external output Tr.
35	2VRP	I	2V _{REF} amp (2V _{REF} AMP) positive phase input terminal.	—
36	2VRN	I	2V _{REF} amp (2V _{REF} AMP) negative phase input terminal.	—

MAXIMUM RATINGS (Ta = 25°C)

CHARACTERISTIC		SYMBOL	RATING	UNIT
Power Supply Voltage		$V_{CC}-V_{EE}$	0.3~12.0	V
Power Dissipation	TA8190F	P_D	960 (*1)	mW
	TA8191F		780 (*2)	
Operating Temperature		T_{opr}	-25~75	°C
Storage Temperature		T_{stg}	-55~150	°C

(*1) Derated above 25°C in the proportion of 7.7mW/°C.

(*2) Derated above 25°C in the proportion of 6.2mW/°C.

ELECTRICAL CHARACTERISTICS

(Unless otherwise specified, TA8190F : $V_{CC}=5V$, $V_{EE}=-5V$, $T_a=25^\circ C$)
 TA8191F : $V_{CC}=5V$, $V_{EE}=GND$, $T_a=25^\circ C$)

CHARACTERISTIC		SYMBOL	TEST CIRCUIT	TEST CONDITION	MIN.	TYP.	MAX.	UNIT
Power Source (TA8190F)	Power Supply Voltage	V_{CC}	—	$T_a = -25 \sim 75^\circ C$	4.5	5.0	5.5	V
		V_{EE}	—		-5.5	-5.0	-4.5	
	Power Supply Current	I_{CC}	1	SEL = HiZ	14.0	24.0	32.0	mA
		I_{EE}	1	—	3.0	5.0	7.0	
Power Source (TA8191F)	Power Supply Voltage	V_{CC}	—	$T_a = -25 \sim 75^\circ C$	4.5	5.0	5.5	V
	Power Supply Current	I_{CC}	3	—	14.0	24.0	32.0	mA
Reference Power Supply V_{REF} (Common)	Reference Voltage	V_{REF}	1, 3	—	1.95	2.10	2.25	V
	Reference Voltage Temperature Characteristic	$\Delta V / \Delta T$	1, 3	—	-3.0	-2.0	-1.0	mV/°C
	Output Current	I_{OH}	1, 3	—	5.0	—	—	mA
	Input Current	I_{OL}	1, 3	—	5.0	—	—	mA
FI ↓ RFO (Common)	Permissive Input Current	I_{IM}	1, 3	per each ch	30	—	—	μA
	Transfer Resistance	R_T	1, 3	$f = 100kHz$	115	127	140	$k\Omega$
	Frequency Characteristic	f_c	2, 4	-3dB point	3.0	—	—	MHz
	Output Signal Slew Rate	SR	2, 4	$CRFO = 20pF$	10	20	—	V/ μs
	Total Harmonic Distortion	THD	1, 3	$f = 100kHz$ $V_{REO} = 1.27V_{p-p}$	—	-40	-30	dB

TEST CIRCUIT 4

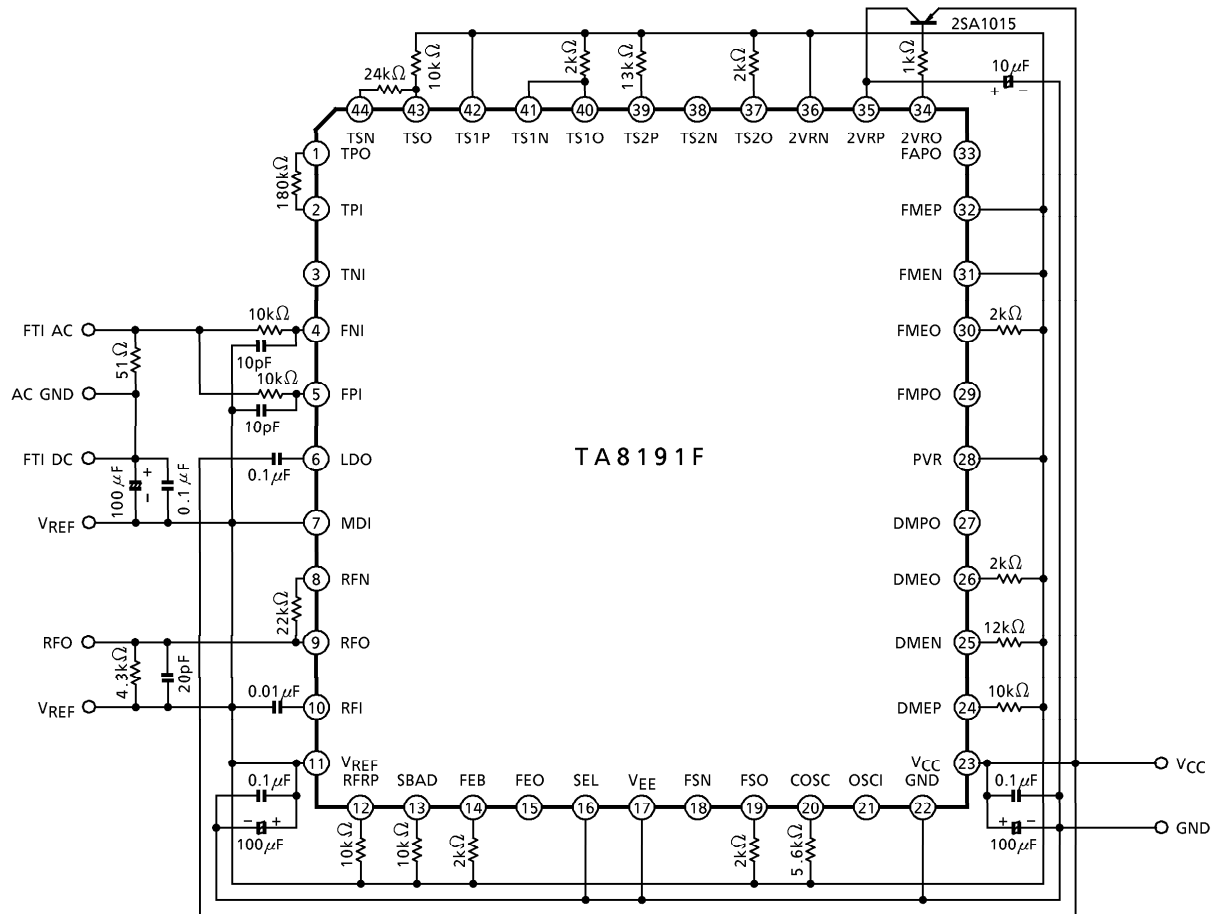

OUTLINE DRAWING
QFP44-P-1414-0.80B

Unit : mm

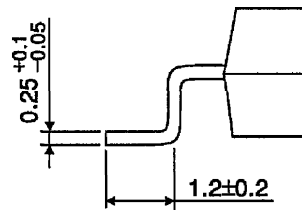
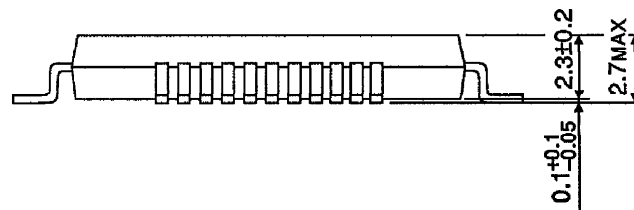
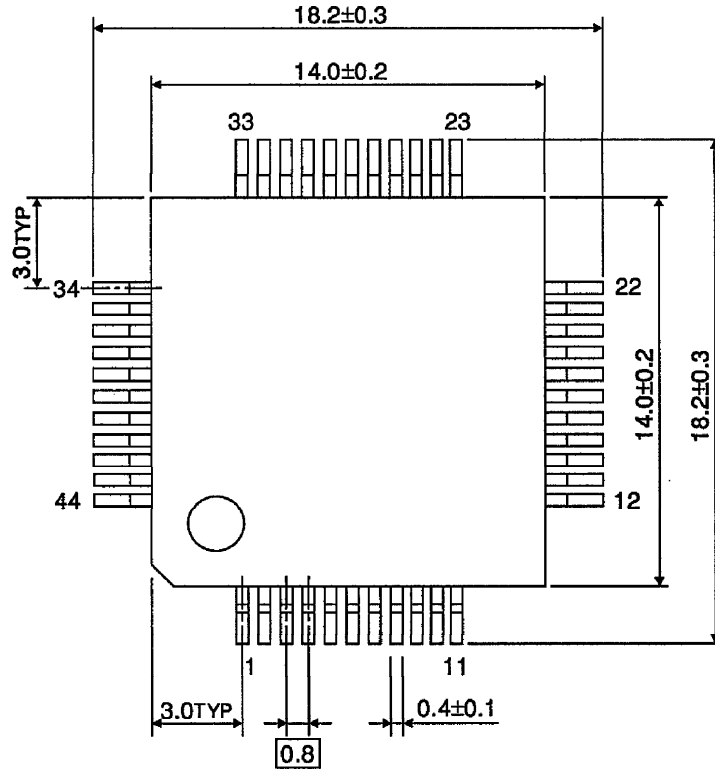

Weight : 1.15g (Typ.)

OUTLINE DRAWING
QFP44-P-1010-0.80C

Unit : mm

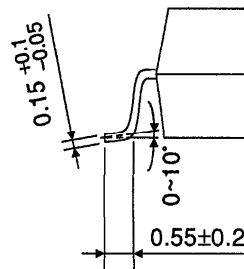
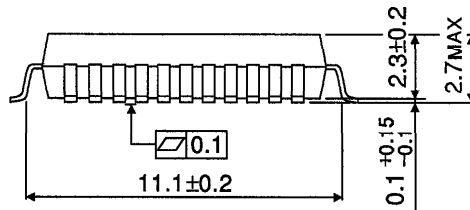
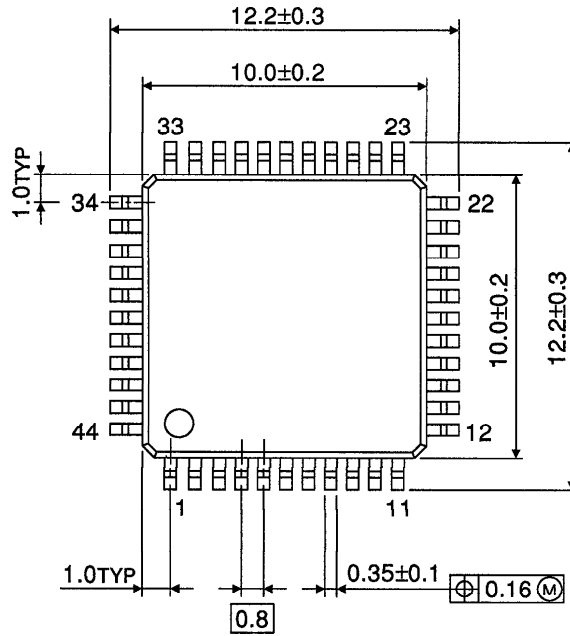

Weight : 0.5g (Typ.)