

TENTATIVE TOSHIBA BIPOLAR LINEAR INTEGRATED CIRCUIT SILICON MONOLITHIC

TA8880CN

VIDEO, CHROMA, AND SYNC. SIGNAL PROCESSING IC FOR PAL / NTSC / SECAM-SYSTEM COLOR TELEVISIONS

The TA8880CN is a signal processing IC for a PAL / NTSC / SECAM-system color television involving video, chroma, and sync. signal processing circuits in a 64-pin shrink DIP plastic package.

The video section contains a high-performance picture quality emphasis circuit, the chroma section contains a PAL / NTSC / SECAM-system automatic identification circuit, and the sync. section contains a 50 / 60Hz automatic identification circuit. The PAL / SECAM demodulating circuit uses a baseband signal processing system, providing an adjustment-free demodulating circuit. User control functions, system switching, etc. are controlled via the I²C bus.

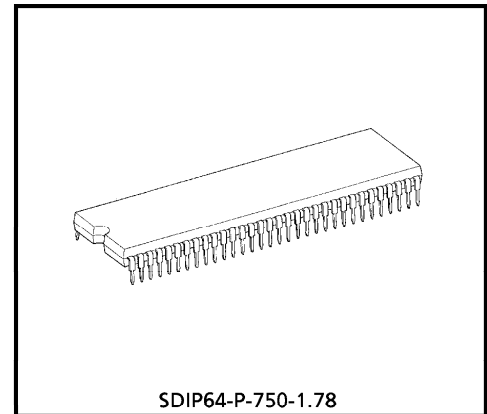

SDIP64-P-750-1.78

Weight : 8.85g (Typ.)

FEATURES

Video section

- Sharpness control with internal delay lines
- Black stretching circuit
- YNR
- Variable DC restoration ratio
- Gamma (γ) contrast correction

Chroma section

- PAL / SECAM baseband demodulation system
- Automatic crystal frequency identification (4.43MHz / 3.58MHz / M, N-PAL)
- Automatic chroma system identification (PAL / NTSC / SECAM)
- PLL SECAM adjustment-free demodulating circuit without any tank coils
- Built-in SECAM BELL filter

Sync. section

- Adjustment-free horizontal and vertical oscillation circuits based on countdown system
- Automatic vertical frequency identification (50 / 60Hz)3

980910EBA2

● TOSHIBA is continually working to improve the quality and the reliability of its products. Nevertheless, semiconductor devices in general can malfunction or fail due to their inherent electrical sensitivity and vulnerability to physical stress. It is the responsibility of the buyer, when utilizing TOSHIBA products, to observe standards of safety, and to avoid situations in which a malfunction or failure of a TOSHIBA product could cause loss of human life, bodily injury or damage to property. In developing your designs, please ensure that TOSHIBA products are used within specified operating ranges as set forth in the most recent products specifications. Also, please keep in mind the precautions and conditions set forth in the TOSHIBA Semiconductor Reliability Handbook.

● The products described in this document are subject to the foreign exchange and foreign trade laws.

● The information contained herein is presented only as a guide for the applications of our products. No responsibility is assumed by TOSHIBA CORPORATION for any infringements of intellectual property or other rights of the third parties which may result from its use. No license is granted by implication or otherwise under any intellectual property or other rights of TOSHIBA CORPORATION or others.



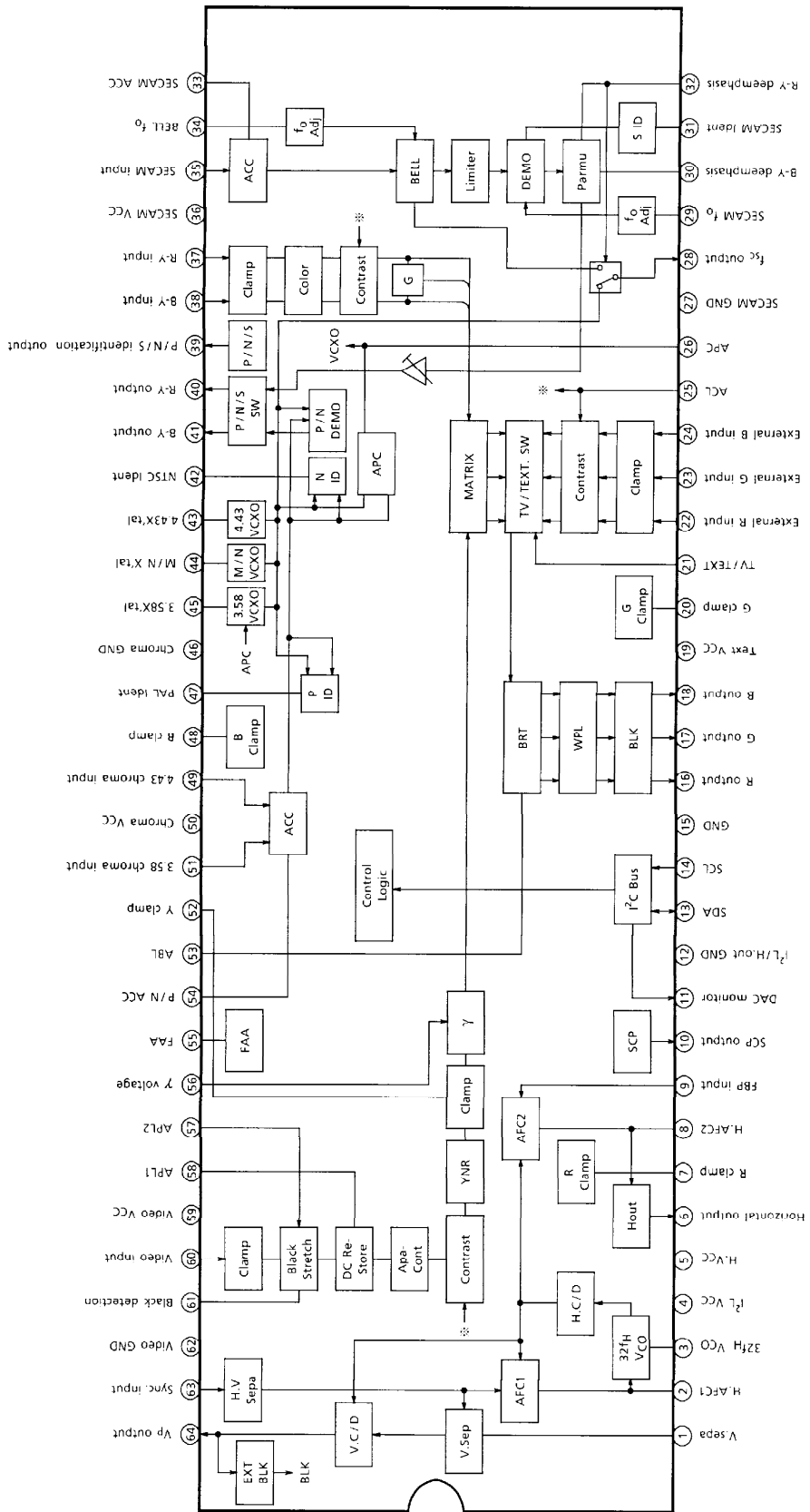

● The information contained herein is subject to change without notice.

BLOCK DIAGRAM



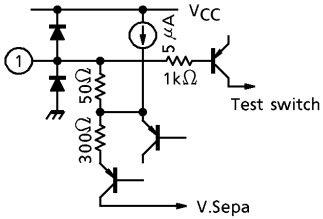

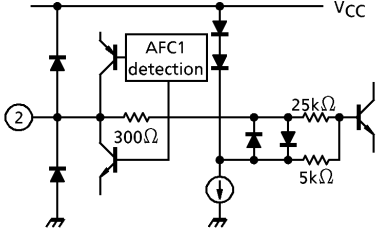
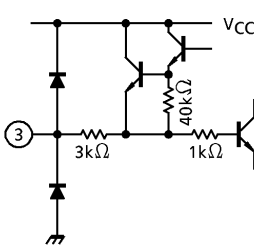
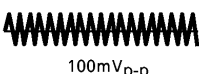
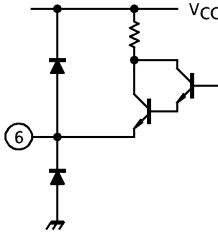
TA8880CN-2

TERMINAL FUNCTION

PIN No.	PIN NAME	FUNCTION	INTERFACE CIRCUIT	TERMINAL SIGNAL
1	V.Sepa	This pin is for a vertical sync. signal separation filter.		<p>DC 6V</p>  <p>100mV_{p-p}</p>
2	H.AFC1	This pin is for a horizontal AFC filter. The voltage at this pin determines the frequency of horizontal output.		<p>DC 7.6V</p>
3	32f _H V _{CO}	This pin is for a ceramic resonator for horizontal oscillation. For this resonator, we recommend the CSB503F30 made by MURATA ELECTRONICS Co.		<p>DC 6V</p>  <p>100mV_{p-p}</p>
4	I ² L V _{CC}	This is the power supply for the logic processing circuit. Apply 3.3V (typ.) to this pin.	—	—
5	H.V _{CC}	This is the power supply for the horizontal sync. circuit. Apply 9V (typ.) to this pin.	—	—
6	Horizontal output	This is a horizontal output terminal.		<p>High : 5V Low : 0V</p>  <p>Duty cycle : 41%</p>

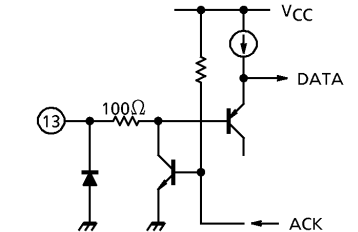
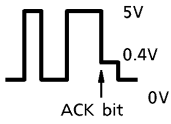
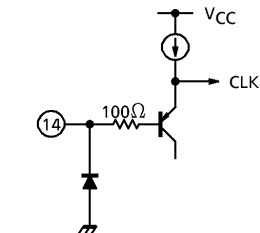
PIN No.	PIN NAME	FUNCTION	INTERFACE CIRCUIT	TERMINAL SIGNAL
7 20 48	R clamp G clamp B clamp	These pins are for the R, G, and B output clamping filters.		DC 3.5V~4.5V
8	H.AFC2	This pin is for a H.AFC2 filter. The voltage at this pin determines the phase of the horizontal output.		DC 7V
9	FBP input	This pin is input terminal for FBP to generate pulses for H.AFC2 and horizontal blanking circuits.		
10	SCP output	This pin outputs a Sand Castle Pulse (SCP). The output signal consists of a clamp pulse, horizontal blanking, and vertical blanking. Use 10kΩ for load resistance.		
11	DAC monitor	(1) Selects a slave address. High : 8AH Low : 88H (2) Can monitor the output voltage of each control DAC. (3) Color control terminal.		DC 3V
12	I ² L / H.out GND	This is the ground for the logic and horizontal output circuits.	—	—

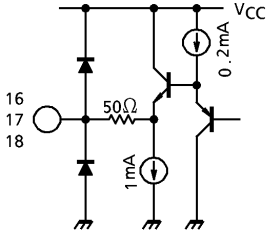
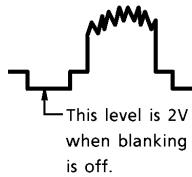
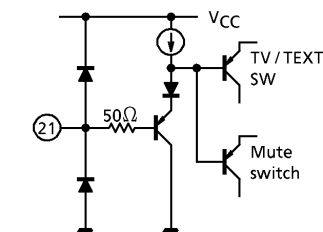
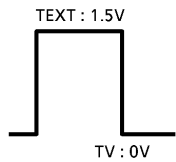
PIN No.	PIN NAME	FUNCTION	INTERFACE CIRCUIT	TERMINAL SIGNAL									
13	SDA	This is a SDA terminal for the I ² C bus. Because its is week for surge inpulse, connect external devices for protection against surge if necessary.											
14	SCL	This is a SCL terminal for the I ² C bus. Because its is week for surge inpulse, connect external devices for protection against surge if necessary.											
15	GND	This is the ground for the sync. and TEXT circuits.	—	—									
16 17 18	R output G output B output	These pins are R, G, and B outputs. When using this device in combination with the TA8889P or TA8889AP, turn its blanking mode off.											
19	TEXT V _{CC}	This is the power supply for the TEXT circuit. Apply 9V (typ.) to this pin.	—	—									
21	TV/TEXT	This pin is a switch selecting the R/G/B output signal between TV signal and external TEXT signal. This pin also is a R/G/B mute switch. V _{th} : <table style="display: inline-table; vertical-align: middle;"> <tr><td>5V</td><td>—</td><td>Mute</td></tr> <tr><td>1V</td><td>—</td><td>TEXT</td></tr> <tr><td>0V</td><td>—</td><td>TV</td></tr> </table>	5V	—	Mute	1V	—	TEXT	0V	—	TV		
5V	—	Mute											
1V	—	TEXT											
0V	—	TV											

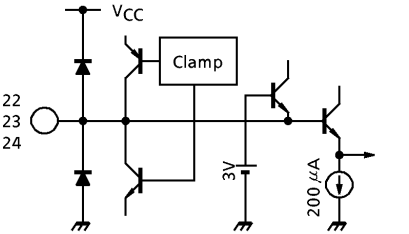
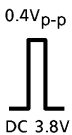
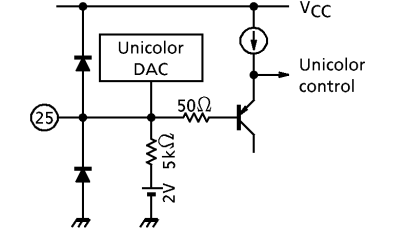
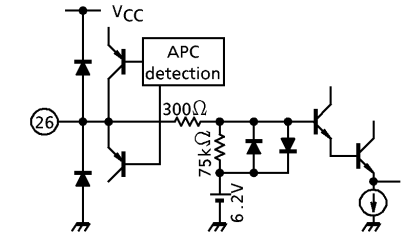
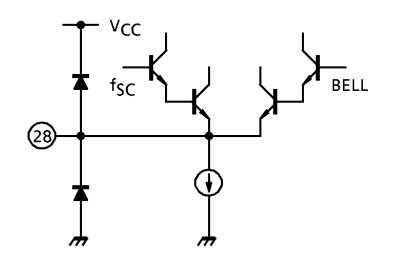
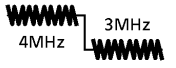
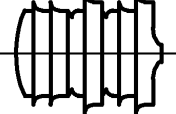
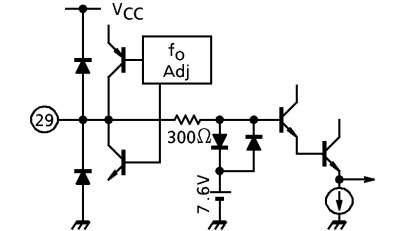
PIN No.	PIN NAME	FUNCTION	INTERFACE CIRCUIT	TERMINAL SIGNAL
22 23 24	External R input External G input External B input	These are external TEXT input pins. Input R / G / B signal through a clamping capacitor.		<p>0.4V_{p-p}</p>  <p>DC 3.8V</p>
25	ACL	This is an external unicolor control terminal. Use this pin when applying ACL.		DC 2V
26	APC	This pin is for an APC filter for PAL / NTSC demodulation. The voltage at this pin determines the oscillation frequency of VCXO.		DC 6.2V
27	SECAM GND	This is the ground for the SECAM demodulator circuit.	—	—
28	f _{SC} output	(1) Outputs the oscillation waveform of VCXO. (2) Outputs the signal through the BELL filter if applying 1V to pin 32.		<p>(1) </p> <p>(2) </p>
29	SECAM f _o	Connect automatic f _o adjusting filter for SECAM PLL demodulation VCO.		DC 7.6V

PIN No.	PIN NAME	FUNCTION	INTERFACE CIRCUIT	TERMINAL SIGNAL
30 32	B-Y deemphasis R-Y deemphasis	This pin is for a SECAM deemphasis capacitor. The output of the BELL filter can be monitored at pin 28 by applying 1V to pin 32.		0.6V _{p-p} 0.7V _{p-p} DC 4.5V
31	SECAM Ident	This pin is for a SECAM Ident filter. Connect a proper value resistance in parallel to prevent mis-identification of color system.		DC 5.2V
33	SECAM ACC	This pin is for a SECAM ACC filter.		DC 4V
34	BELL f ₀	This pin is for an automatic f ₀ adjusting filter for the BELL filter.		DC 6V
35	SECAM input	This pin is for the SECAM chroma signal input. Input the chroma signal through a broadband 4.3MHz BPF to improve the color signal edge shape on the condition of small signal input.		Id ; 100mV _{p-p} DC 2V
36	SECAM V _{CC}	This is the power supply for the SECAM demodulator circuit.	—	—

PIN No.	PIN NAME	FUNCTION	INTERFACE CIRCUIT	TERMINAL SIGNAL
37 38	R-Y input B-Y input	These are input terminals for R-Y and B-Y signals. Input R-Y and B-Y signals through a clamping capacitor.		0.7V _{p-p} 0.6V _{p-p} DC 4.5V
39	P/N/S identification output	This pin shows the system identification, PAL, SECAM or NTSC. For the black and white identification, this pin keeps the immediate voltage. The voltage at this pin immediately after power-on is indeterminate.		DC PAL 8.3V SECAM 4.6V NTSC 0V
40 41	R-Y output B-Y output	These pins output the R-Y and B-Y signals.		0.7V _{p-p} 0.6V _{p-p} DC 3.3V
42 47	NTSC Ident PAL Ident	This pin is for a PAL/NTSC Ident filter. The color killer sensitivity can be set by connecting resistance in parallel to prevent misidentification.		DC 6.2V
43 44 45	4.43X'tal M/N X'tal 3.58X'tal	These pins are for crystal resonators. Use the series capacitance to vary the free running frequency, f_0 , and the parallel capacitance to vary the frequency control range.		DC 5.7V 150mV _{p-p}
46	Chroma GND	This is the ground for the PAL/NTSC demodulator circuit.	—	—

PIN No.	PIN NAME	FUNCTION	INTERFACE CIRCUIT	TERMINAL SIGNAL
49 51	4.43 chroma input 3.58 chroma input	These pins are the 4.43 / 3.58MHz chroma signal inputs. Input the chroma signal through a BPF.		
50	Chroma VCC	This is the power supply for the PAL/NTSC demodulator circuit. Apply 9V (typ.) to this pin.	—	—
52	Y clamp	This pin is for a clamp filter for the video signal circuit.		DC 2V
53	ABL	This is an external brightness control terminal. Use this pin when applying ABL.		DC 2V
54	ACC	This pin is for a PAL/NTSC ACC filter.		DC 5.8V
55	FAA	This pin is for a filter of automatic f _o adjustment circuit for the built-in filters. The voltage at this filter determines the sharpness peak frequency, BELL center frequency and SECAM demodulation center frequency.		DC 4.5V

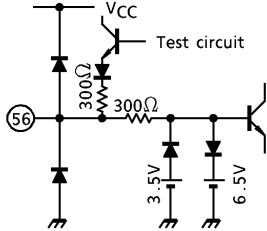
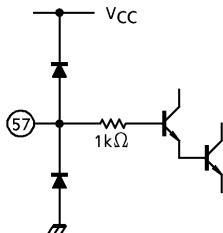
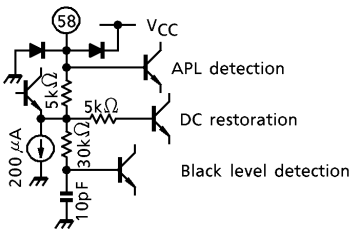
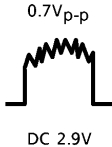
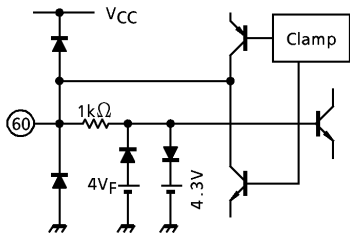
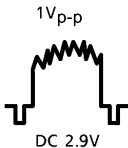
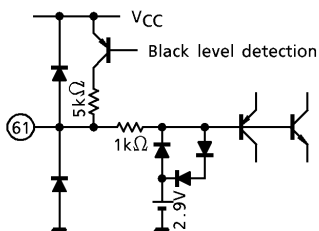
PIN No.	PIN NAME	FUNCTION	INTERFACE CIRCUIT	TERMINAL SIGNAL
56	Gamma (γ) voltage	The voltage at this pin determines the starting point of γ compensation for the video signal. This is also a test pin.		DC 5V
57	APL2	The voltage at this pin determines the starting point of black stretching.		DC 3.2V
58	APL1	This pin is for a filter to determine the DC restoration ratio. The black-stretched video signal is appeared at this pin.		
59	Video VCC	This is the power supply for the video circuit. Apply 9V (typ.) to this pin.	—	—
60	Video input	This pin is the video signal input. Input the video signal through a clamping capacitor.		
61	Black detection	This pin is for a filter to detect the black level of video signal. The voltage at this pin determines the black stretching gain.		DC 2.9V

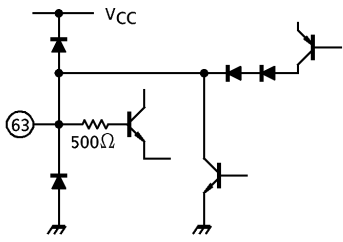
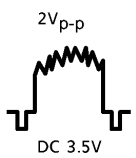
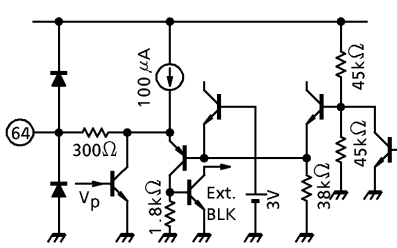
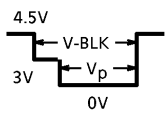
PIN No.	PIN NAME	FUNCTION	INTERFACE CIRCUIT	TERMINAL SIGNAL
62	Video GND	This is the ground for the video circuit.	—	—
63	Sync. input	This pin is input for the sync. separation circuit. Input the sync. signal through a clamping capacitor.		
64	V _p output	This is a vertical pulse output terminal. This pin is also an external vertical blanking input. Blanking is applied after being OR'ed with the internal blanking.		

TERMINAL SIGNAL : Standard input/output signals under normal operation.

BUS CONTROL MAP

Write data (Standard slave address 88H)

SUB ADDRESS	MSB 7	6	5	4	3	2	1	LSB 0	INITIAL VALUE AT POWER-ON	
									MSB	LSB
00	WPL	Color							0100	0000
01	Sharpness SW	TINT (for NTSC only)							0100	0000
02		Brightness							0100	0000
03	P/N GP	Unicolor							0100	0000
04	Vertical mode	Sharpness							0010	0000
05	Vertical phase adjustment	Horizontal phase adjustment							0001	0000
06	Mute mode	BLK	B/W	X'tal mode	Color system				0100	0000
07	P/N amplitude	SECAM amplitude	BELL filter f ₀ adjustment			S GP	S ID	0001		0000
08	SECAM black level adjustment R-Y			SECAM black level adjustment B-Y					1000	1000
09	Search	Blue back	YNR	AFC	Test mode selection				0000	0000

Read data (Standard slave address 89H)

	PONRES	Color system	X'tal mode	Vertical F	Reserved
--	--------	--------------	------------	------------	----------

TEST CIRCUIT 1

Main unit

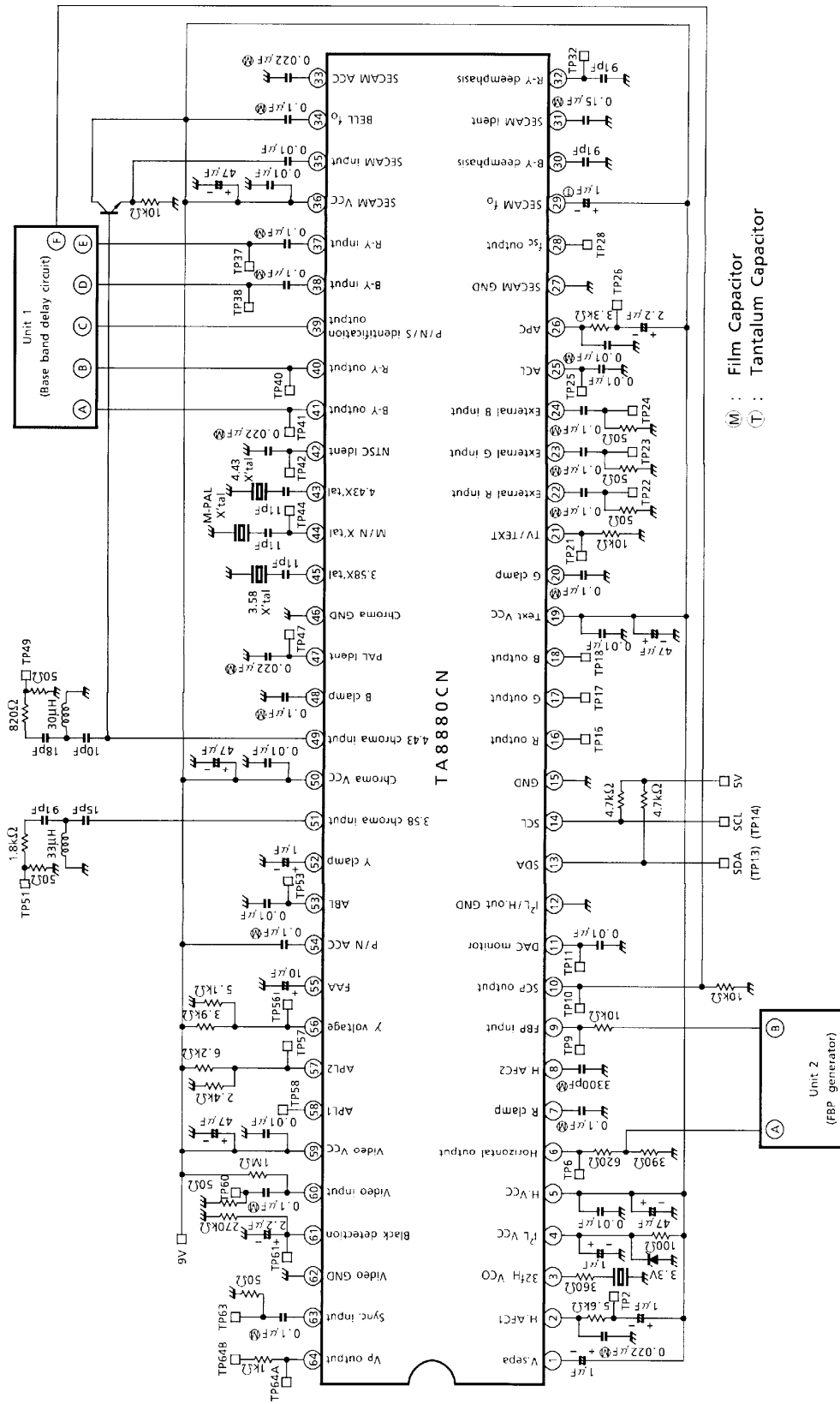

Ⓜ : Film Capacitor
Ⓣ : Tantalum Capacitor

APPLICATION EXAMPLE CIRCUIT 2 (FOR NTSC/M PAL/N PAL)

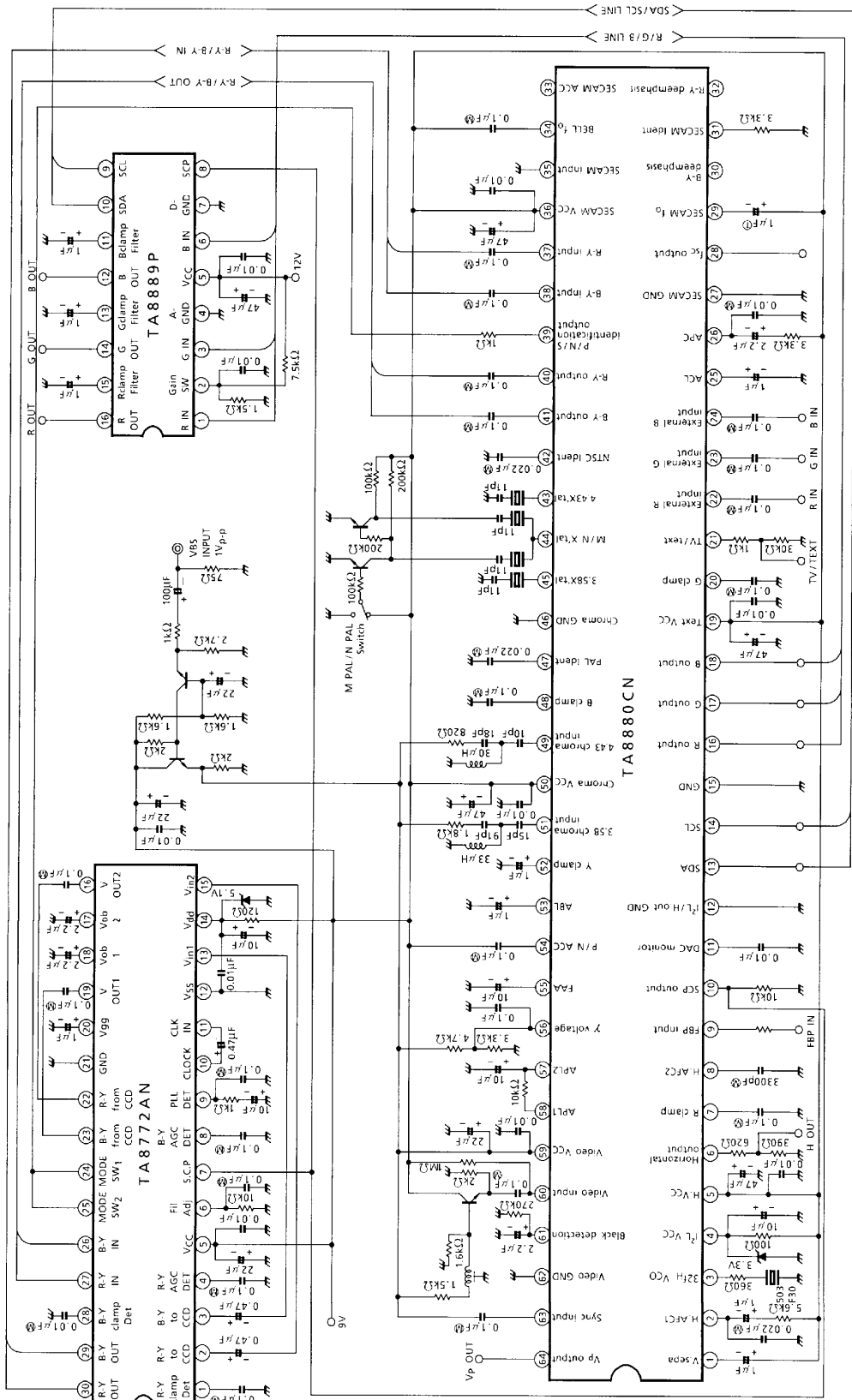

(M) : Film Capacitor
(T) : Tantalum Capacitor

OUTLINE DRAWING
SDIP64-P-750-1.78

Unit : mm

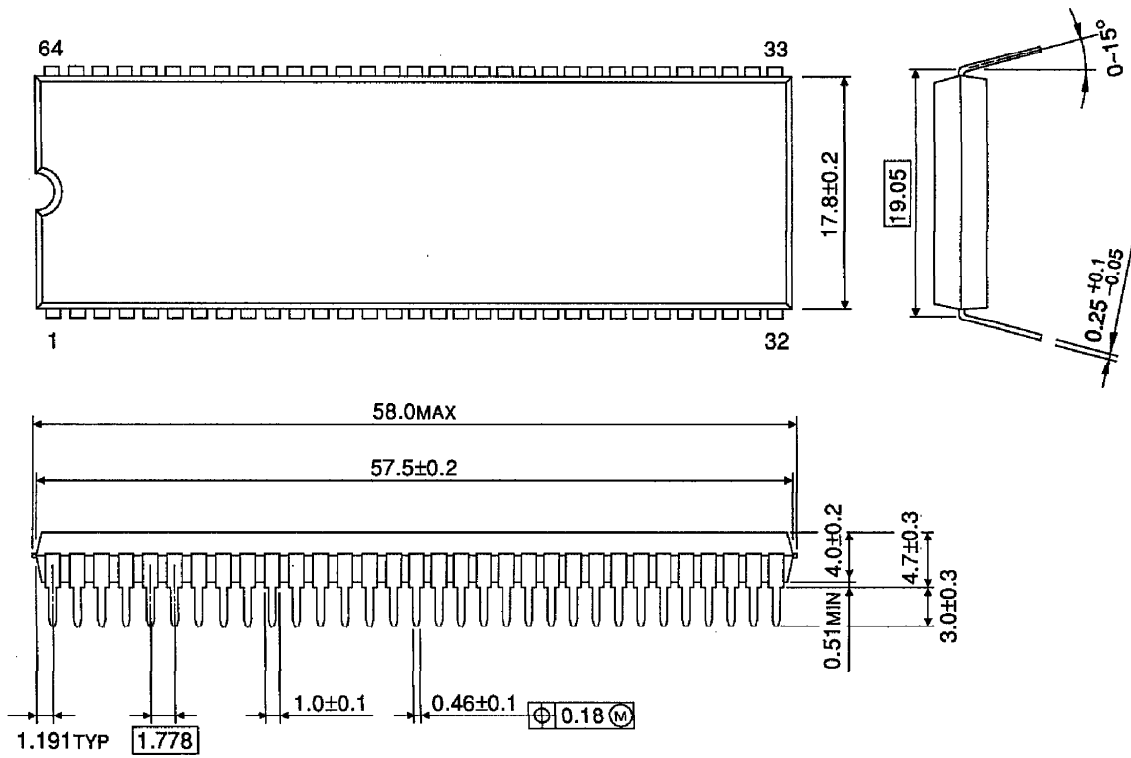

Weight : 8.85g (Typ.)