

# HD2912

## Quadruple TTL-to-MOS Clock Drivers

The HD2912, a clock driver for the MOS memory, has basically the NAND function. Its input is a TTL level and its output becomes an N MOS clock input level. It operates on two power supplies –  $V_{CC}$  (5V) and  $V_{DD}$  (12V). It anticipates taking as its load a maximum of ten units of 4K-bit N MOS memories and can drive a load capacity of 400 pF at high speed.

- TTL-MOS level converter circuit
- Switching time: 50 ns (max.)
- Load capacity drivable: 600pF
- Mounted with 4 circuits
- Applicable temperature: 0 to 70°C

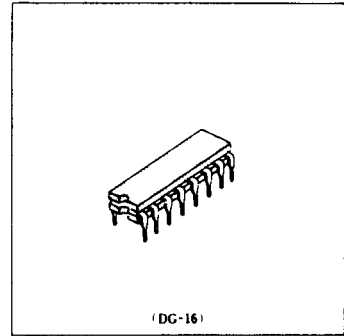

### ■ ABSOLUTE MAXIMUM RATINGS

Item	Symbol	HD2912	Unit
Supply Voltage	$V_{CC}^*$	7.0	V
	$V_{DD}^*$	18.0	V
Input Voltage	$V_{i.s}^*$	5.5	V
Load Capacitance	$C_L^{**}$	600	pF
Power Dissipation	$P_T^{***}$	800	mW
Operating Temperature	$T_{opr}$	0 to +70	°C
Storage Temperature	$T_{stg}$	-65 to +150	°C

\* With respect GND

\*\* per circuit

\*\*\* per package

### ■ RECOMMENDED OPERATING CONDITIONS

Item	Symbol	min	typ	max	Unit
Supply Voltage	$V_{CC}$	4.75	5.0	5.25	V
	$V_{DD}$	11.4	12	12.6	V
Operating Temperature	$T_{opr}$	0	25	70	°C
Load Capacitance	$C_L$	100	—	600	pF
Damping Resistance	$R_D$	10	—	—	$\Omega$

### ■ ELECTRICAL CHARACTERISTICS ( $T_a=0$ to +70°C, $V_{CC}=5V \pm 5\%$ , $V_{DD}=12V \pm 5\%$ )

Item	Symbol	Test Condition	min	typ*	max	Unit	
Input Voltage	$V_{iL}$		2.0	—	—	V	
	$V_{iH}$		—	—	0.8	V	
Output Voltage	$V_{oL}$	$V_{i.s}=2V, I_{oL}=0.1mA$	—	0.45	0.6	V	
	$V_{oH}$	$V_{i.s}=0.8V, I_{oH}=-0.1mA$	$V_{DD}-0.9$	11.5	—	V	
Input Current	A	$I_{iL}$	—	-1	-1.6	mA	
	B	$I_{iL}$	—	-2	-3.2	mA	
	A	$I_{iH}$	—	—	40	$\mu A$	
	B	$I_{iH}$	$V_{i.s}=2.4V$	—	—	80	$\mu A$
Power Supply Current		$I_I$	$V_{i.s}=5.5V$	—	—	1	mA
		$I_{DDH}$	$V_{i.s}=0V$	—	16	24	mA
		$I_{DDL}$	$V_{i.s}=5V$	—	—	0.5	mA
		$I_{CCN}$	$V_{i.s}=0V$	—	12	18	mA
		$I_{CCL}$	$V_{i.s}=5V$	—	67	100	mA
Input Clamp Voltage	$V_i$	$I_{i.s}=-12mA$	—	—	-1.5	V	

\*  $V_{CC}=5V, V_{DD}=12V$

### ■ PIN ARRANGEMENT

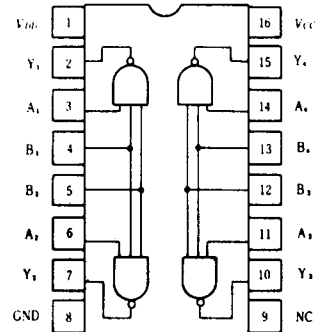

(Top View)

■ SWITCHING CHARACTERISTICS ( $T_a=0$  to  $+70^\circ\text{C}$ ,  $V_{CC}=5\text{V}$ ,  $V_{DD}=12\text{V}$ )

Item	Symbol	Test Condition	min	typ	max	Unit
Rising Delay Time	$t_{DLN}$	$C_L=300\text{pF}$ $R_D=0\Omega$	—	35	50	ns
Falling Delay Time	$t_{DNL}$		—	25	45	ns
Rise Time	$t_{TLN}$		—	12	25	ns
Fall Time	$t_{TNL}$		—	12	25	ns

● TEST CIRCUIT AND WAVEFORMS

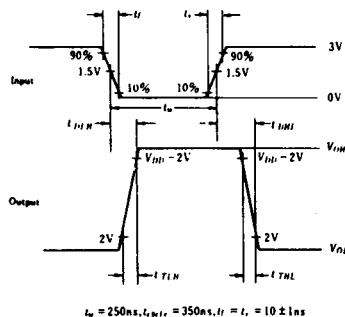
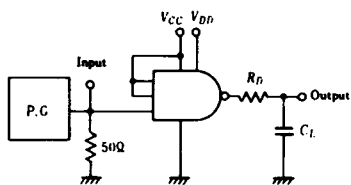

$t_w = 250\text{ns}$ ,  $t_{HI} = 350\text{ns}$ ,  $t_r = t_f = 10 \pm 1\text{ns}$

FALLING DELAY TIME vs. LOAD CAPACITANCE (1)

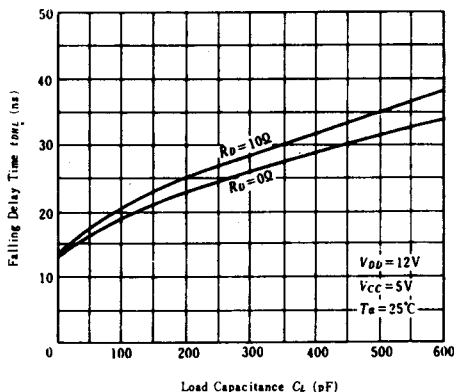

RISING DELAY TIME vs. LOAD CAPACITANCE (2)

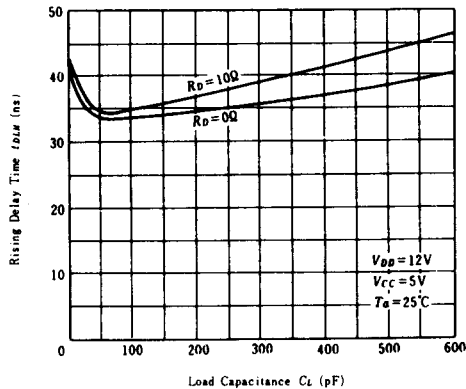

RISE TIME AND RISING DELAY TIME vs. AMBIENT TEMPERATURE

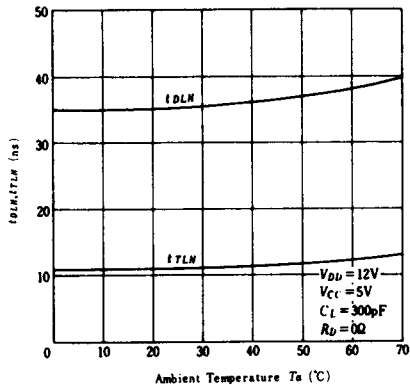

FALL TIME AND FALLING DELAY TIME vs. AMBIENT TEMPERATURE

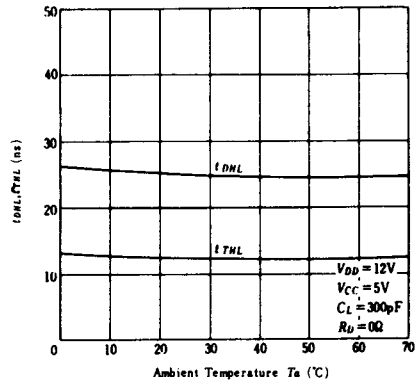

**SWITCHING TIME vs. SUPPLY VOLTAGE (1)**

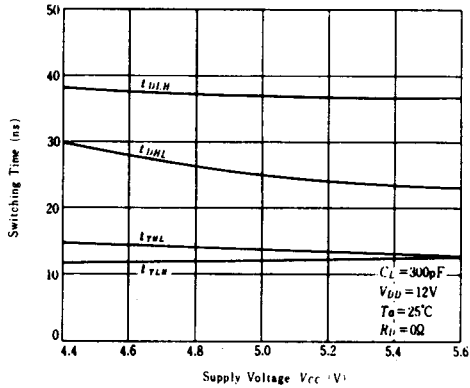

**SWITCHING TIME vs. SUPPLY VOLTAGE (2)**

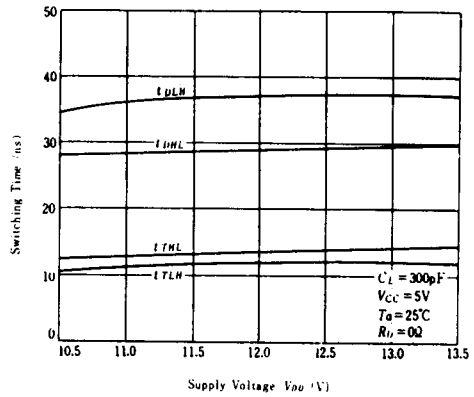

**POWER DISSIPATION vs. CYCLE TIME**

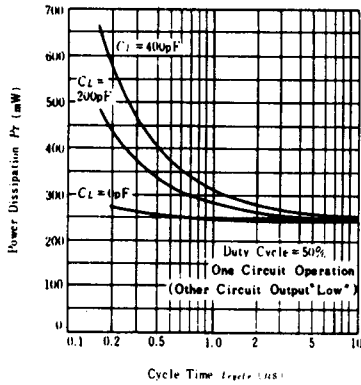

**■ ITEMS REQUIRING CARE WHEN USING THE HD2912**

When measuring or mounting the HD2912, consider the following.

1. At the time of "H" level output, if a short circuit occurs between the output terminal and the other terminal (the GND terminal or input terminal), the element will breakdown.
2. When measuring the input/output characteristic of the circuit, do not place the input level in the vicinity of the threshold voltage (about 1.5V) for more than 10 seconds. If this caution is neglected, the element may breakdown.
3. If its load capacity is less than a certain value (100pF), sometimes this element cannot fully provide its function. Take note of this fact when designing a system.
4. When mounting this element, it is recommended providing the output terminal with a damping resistor ( $R_D$ ) or a diode terminating circuit.

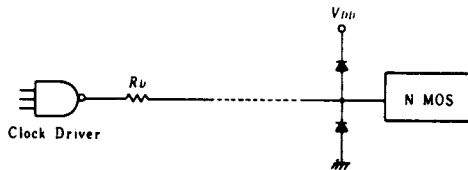

This datasheet has been downloaded from:

[www.DatasheetCatalog.com](http://www.DatasheetCatalog.com)

Datasheets for electronic components.



LittleDiode supplies new, hard to find or obsolete electronic components and semiconductors all over the world.

With over two million different components listed you are sure to find the part you need.

Feel free to visit us today at our online store:

[LittleDiode.com](http://LittleDiode.com)

Looking forward to providing you with the best possible service.