

## DS8906 AM/FM Digital Phase-Locked Loop Synthesizer

### General Description

The DS8906 is a PLL synthesizer designed specifically for use in AM/FM radios. It contains the reference oscillator, a phase comparator, a charge pump, a 120 MHz ECL/ $1^2$ L dual modulus programmable divider, and a 20-bit shift register/latch for serial data entry. The device is designed to operate with a serial data controller generating the necessary division codes for each frequency, and logic state information for radio function inputs/outputs.

The Colpitts reference oscillator for the PLL operates at 4 MHz. A chain of dividers is used to generate a 500 kHz clock signal for the external controller. Additional dividers generate a 12.5 kHz reference signal for FM and a 500 Hz reference signal for AM/SW. One of these reference signals is selected by the data from the controller for use by the phase comparator. Additional dividers are used to generate a 50 Hz timing signal used by the controller for "time-of-day".

Data is transferred between the frequency synthesizer and the controller via a 3 wire bus system. This consists of a data input line, an enable line and a clock line. When the enable line is low, data can be shifted from the controller into the frequency synthesizer. When the enable line is transitioned from low to high, data entry is disabled and data present in the shift register is latched.

From the controller 22-bit data stream, the first 2 bits address the device permitting other devices to share the same bus. Of the remaining 20-bit data word, the next 14-bits are used for the PLL divide code. The remaining 6 bits are connected via latches to output pins. These 6 bits can be used to drive radio functions such as gain, mute, FM, AM, LW and SW only. These outputs are open collector. Bit 18 is used internally to select the AM or FM local oscillator input and to select between the 500 Hz and 12.5 kHz reference. A high level at bit 18 indicates FM and a low level indicates AM.

The PLL consists of a 14-bit programmable  $1^2$ L divider, an ECL phase comparator, an ECL dual modulus ( $p/p + 1$ ) prescaler, and a high speed charge pump. The programmable divider divides by  $(N + 1)$ , N being the number loaded into the shift register (bits 1–14 after address). It is clocked by the AM input via an ECL  $\div 7/8$  prescaler, or through a  $\div 63/64$  prescaler from the FM input. The AM input will work at frequencies up to 8 MHz, while the FM input works up to 120 MHz. The AM band is tuned with a frequency resolution of 500 Hz and the FM band is tuned with a resolution of 12.5 kHz. The buffered AM and FM inputs are self-biased and can be driven directly by the VCO thru a capacitor. The ECL phase comparator produces very accurate resolution of the phase difference between the input signal and the reference oscillator.

The high speed charge pump consists of a switchable constant current source ( $-0.3$  mA) and a switchable constant current sink ( $+0.3$  mA). If the VCO frequency is low, the charge pump will source current, and sink current if the VCO frequency is high.

A separate  $V_{CCM}$  pin (typically drawing 1.5 mA) powers the oscillator and reference chain to provide controller clocking frequencies when the balance of the PLL is powered down.

### Features

- Uses inexpensive 4 MHz reference crystal
- $F_{IN}$  capability greater than 120 MHz allows direct synthesis at FM frequencies
- FM resolution of 12.5 kHz allows usage of 10.7 MHz ceramic filter distribution
- Serial data entry for simplified control
- 50 Hz output for "time-of-day" reference with separate low power supply ( $V_{CCM}$ )
- 6-open collector buffered outputs for band switching and other radio functions
- Separate AM and FM inputs. AM input has 15 mV (typical) hysteresis

### Connection Diagram

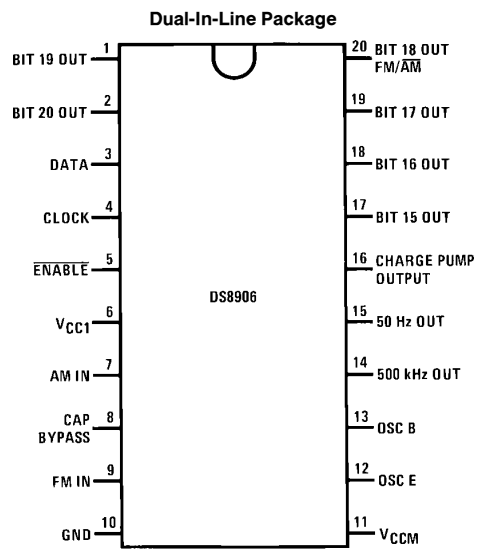

TL/F/5775-1

Top View  
Order Number DS8906N  
See NS Package Number N20A

## Absolute Maximum Ratings (Note 1)

If Military/Aerospace specified devices are required, please contact the National Semiconductor Sales Office/Distributors for availability and specifications.

Supply Voltage (V <sub>CC1</sub> )	7V
(V <sub>CCM</sub> )	7V
Input Voltage	7V
Output Voltage	7V

Storage Temperature Range –65°C to +150°C  
Lead Temperature (Soldering, 4 seconds) 260°C

## Operating Conditions

	Min	Max	Units
Supply Voltage, V <sub>CC</sub>			
V <sub>CC1</sub>	4.75	5.25	V
V <sub>CCM</sub>	4.5	6.0	V
Temperature, T <sub>A</sub>	0	70	°C

## DC Electrical Characteristics (Notes 2 and 3)

Symbol	Parameter	Conditions	Min	Typ	Max	Units	
V <sub>IH</sub>	Logical "1" Input Voltage		2.1			V	
I <sub>IH</sub>	Logical "1" Input Current	V <sub>IN</sub> = V <sub>CC1</sub>		0	10	μA	
V <sub>IL</sub>	Logical "0" Input Voltage				0.7	V	
I <sub>IL</sub>	Logical "0" Input Current	Data, Clock and $\overline{\text{ENABLE}}$ INPUTS, V <sub>IN</sub> = 0V		–5	–25	μA	
I <sub>OH</sub>	Logical "1" Output Current All Bit Outputs, 50 Hz Output	V <sub>OH</sub> = 5.25V			50	μA	
	500 kHz Output	V <sub>OH</sub> = 2.4V, V <sub>CCM</sub> = 4.5V			–250	μA	
V <sub>OL</sub>	Logical "0" Output Voltage All Bit Outputs	I <sub>OL</sub> = 5 mA			0.5	V	
	50 Hz Output, 500 kHz Output	I <sub>OL</sub> = 250 μA			–0.5	V	
I <sub>CC1</sub>	Supply Current (V <sub>CC1</sub> )	All Bit Outputs High		90	160	mA	
I <sub>CCM(STANDBY)</sub>	V <sub>CCM</sub> Supply Current	V <sub>CCM</sub> = 6.0V, All Other Pins Open		1.5	4.0	mA	
I <sub>OUT</sub>	Charge Pump Output Current	1.2V ≤ V <sub>OUT</sub> ≤ V <sub>CCM</sub> – 1.2V V <sub>CCM</sub> ≤ 6.0V	Pump Up	–0.10	–0.30	–0.6	mA
			Pump Down	0.10	0.30	0.6	mA
			TRI-STATE®		0	±100	nA
I <sub>CCM(OPERATE)</sub>	V <sub>CCM</sub> Supply Current	V <sub>CCM</sub> = 6.0V, V <sub>CC1</sub> = 5.25V, All Other Pins Open		2.5	6.0	mA	

## AC Electrical Characteristics V<sub>CC</sub> = 5V, T<sub>A</sub> = 25°C, t<sub>r</sub> ≤ 10 ns, t<sub>f</sub> ≤ 10 ns

Symbol	Parameter	Conditions	Min	Typ	Max	Units
V <sub>IN(MIN)(F)</sub>	F <sub>IN</sub> Minimum Signal Input	AM and FM Inputs, 0°C ≤ T <sub>A</sub> ≤ 70°C		20	100	mV (rms)
V <sub>IN(MAX)(F)</sub>	F <sub>IN</sub> Maximum Signal Input	AM and FM Inputs, 0°C ≤ T <sub>A</sub> ≤ 70°C	1000	1500		mV (rms)
F <sub>OPERATE</sub>	Operating Frequency Range (Sine Wave Input)	V <sub>IN</sub> = 100 mV rms 0°C ≤ T <sub>A</sub> ≤ 70°C		AM 60	8 120	MHz MHz
R <sub>IN (FM)</sub>	AC Input Resistance, FM	120 MHz, V <sub>IN</sub> = 100 mV rms	300			Ω
R <sub>IN (AM)</sub>	AC Input Resistance, AM	2 MHz, V <sub>IN</sub> = 100 mV rms	1000			Ω
C <sub>IN</sub>	Input Capacitance, FM and AM	V <sub>IN</sub> = 120 MHz	3	6	10	pF
t <sub>EN1</sub>	Minimum $\overline{\text{ENABLE}}$ High Pulse Width			625	1250	ns
t <sub>EN0</sub>	Minimum $\overline{\text{ENABLE}}$ Low Pulse Width			375	750	ns
t <sub>CLK<math>\overline{\text{EN}}</math>0</sub>	Minimum Time before $\overline{\text{ENABLE}}$ Goes Low that CLOCK must be Low			–50	0	ns
t <sub>EN0CLK</sub>	Minimum Time after $\overline{\text{ENABLE}}$ Goes Low that CLOCK must Remain Low			275	550	ns
t <sub>CLKEN1</sub>	Minimum Time before $\overline{\text{ENABLE}}$ Goes High that Last Positive CLOCK Edge May Occur			300	600	ns

## AC Electrical Characteristics $V_{CC} = 5V, T_A = 25^{\circ}C, t_r \leq 10 \text{ ns}, t_f \leq 10 \text{ ns}$ (Continued)

Symbol	Parameter	Conditions	Min	Typ	Max	Units
$t_{EN1CLK}$	Minimum Time After ENABLE Goes High Before an Unused Positive CLOCK Edge May Occur			175	350	ns
$t_{CLKH}$	Minimum CLOCK High Pulse Width			275	550	ns
$t_{CLKL}$	Minimum CLOCK Low Pulse Width			400	800	ns
$t_{DS}$	Minimum DATA Setup Time, Minimum Time Before CLOCK that DATA Must be Valid			150	300	ns
$t_{DH}$	Minimum DATA Hold Time, Minimum Time After CLOCK that DATA Must Remain Valid			400	800	ns

**Note 1:** "Absolute Maximum Ratings" are those values beyond which the safety of the device cannot be guaranteed. Except for "Operating Temperature Range" they are not meant to imply that the devices should be operated at these limits. The table of "Electrical Characteristics" provides conditions for actual device operation.

**Note 2:** Unless otherwise specified min/max limits apply across the  $0^{\circ}C$  to  $+70^{\circ}C$  temperature range for the DS8906.

**Note 3:** All currents into device pins shown as positive, out of device pins as negative, all voltages referenced to ground unless otherwise noted. All values shown as max or min on absolute value basis.

## Schematic Diagrams (DS8906 AM/FM PLL Typical Input/Output Schematics)

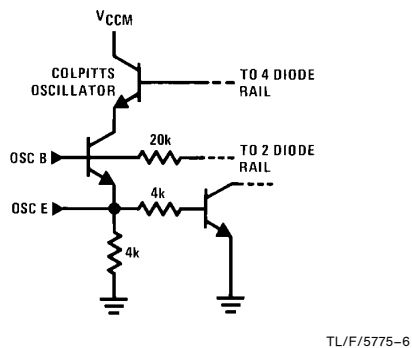
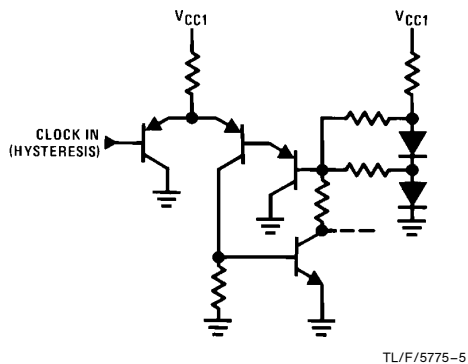
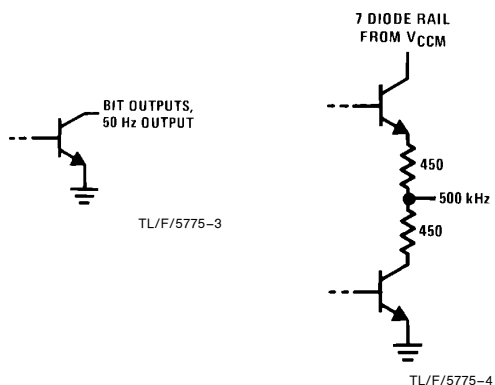
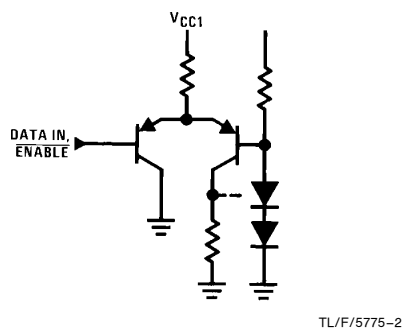

**Schematic Diagrams** (DS8906 AM/FM PLL Typical Input/Output Schematics) (Continued)

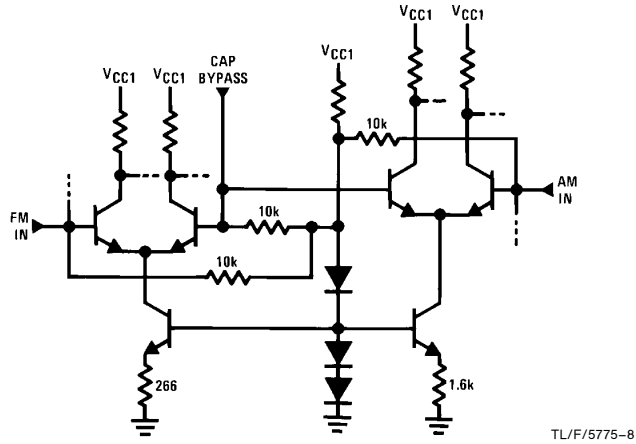
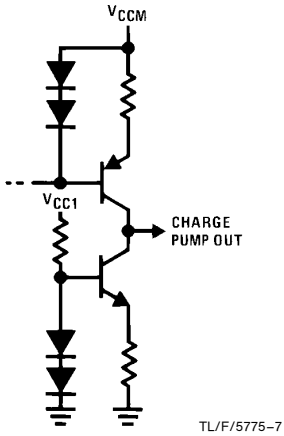

**Timing Diagrams\***

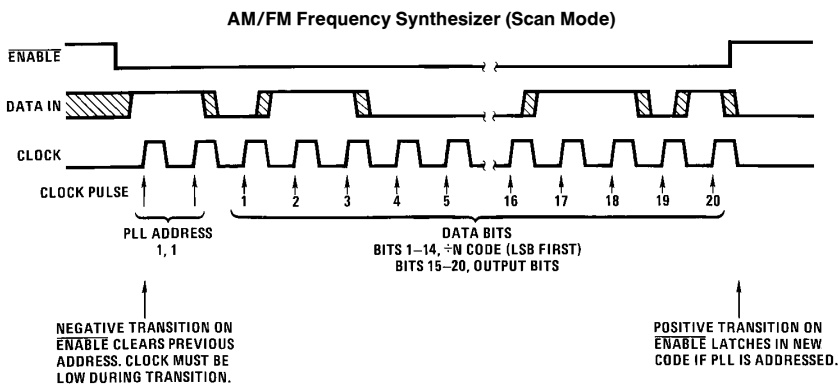
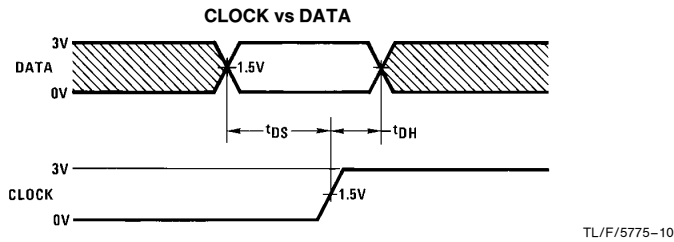
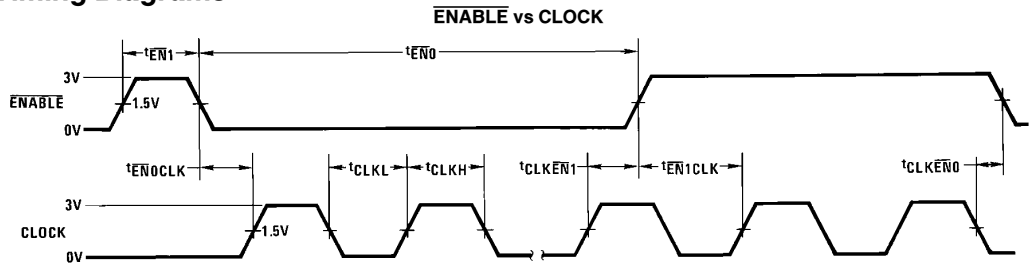

\*Timing diagrams are not drawn to scale. Scale within any one drawing may not be consistent, and intervals are defined positive as drawn.

## Applications Information

### SERIAL DATA ENTRY INTO THE DS8906

Serial information entry into the DS8906 is enabled by a low level on the  $\overline{\text{ENABLE}}$  input. One binary bit is then accepted from the DATA input with each positive transition of the CLOCK input. The CLOCK input must be low for the specified time preceding and following the negative transition of the  $\overline{\text{ENABLE}}$  input.

The first 2 bits accepted following the negative transition of the  $\overline{\text{ENABLE}}$  input are interpreted as address. If these address bits are *not* 1,1, *no* further information will be accepted from the DATA inputs, and the internal data latches *will not* be changed when  $\overline{\text{ENABLE}}$  returns high.

If these first 2 bits *are* 1,1, then all succeeding bits are *accepted* as data, and are shifted successively into the internal shift register as long as  $\overline{\text{ENABLE}}$  remains low.

Any *data* bits preceding the 20th to last bit will be shifted out, and are thus irrelevant. Data bits are counted as any bits following 2 valid (1,1) address bits with the  $\overline{\text{ENABLE}}$  low.

When the  $\overline{\text{ENABLE}}$  input returns high, any further serial data input is inhibited. Upon this positive transition of the  $\overline{\text{ENABLE}}$ , the data in the internal shift register is transferred into the internal data latches.

Note that until this time, the states of the internal data latches have remained unchanged.

These data bits are interpreted as follows:

DATA BIT POSITION	DATA INTERPRETATION
Last	Bit 20 Output (Pin 2)
2nd to Last	Bit 19 Output (Pin 1)
3rd to Last	Bit 18 Output (FM/ $\overline{\text{AM}}$ ) (Pin 20)
4th to Last	Bit 17 Output (Pin 19)
5th to Last	Bit 16 Output (Pin 18)
6th to Last	Bit 15 Output (Pin 17)
7th to Last	$\left. \begin{array}{l} \text{MSB of N } (2^{13}) \\ (2^{12}) \\ (2^{11}) \\ (2^{10}) \\ (2^9) \\ (2^8) \\ (2^7) \\ (2^6) \\ (2^5) \\ (2^4) \\ (2^3) \\ (2^2) \\ (2^1) \\ \text{LSB of N } (2^0) \end{array} \right\} \div \text{N}$
8th to Last	
9th to Last	
10th to Last	
11th to Last	
12th to Last	
13th to Last	
14th to Last	
15th to Last	
16th to Last	
17th to Last	
18th to Last	
19th to Last	
20th to Last	

**Note.** The actual divide code is  $\text{N} + 1$ , i.e., the number loaded plus 1.

# Typical Application

## Electronically Tuned Radio Controller System; Direct Drive LED

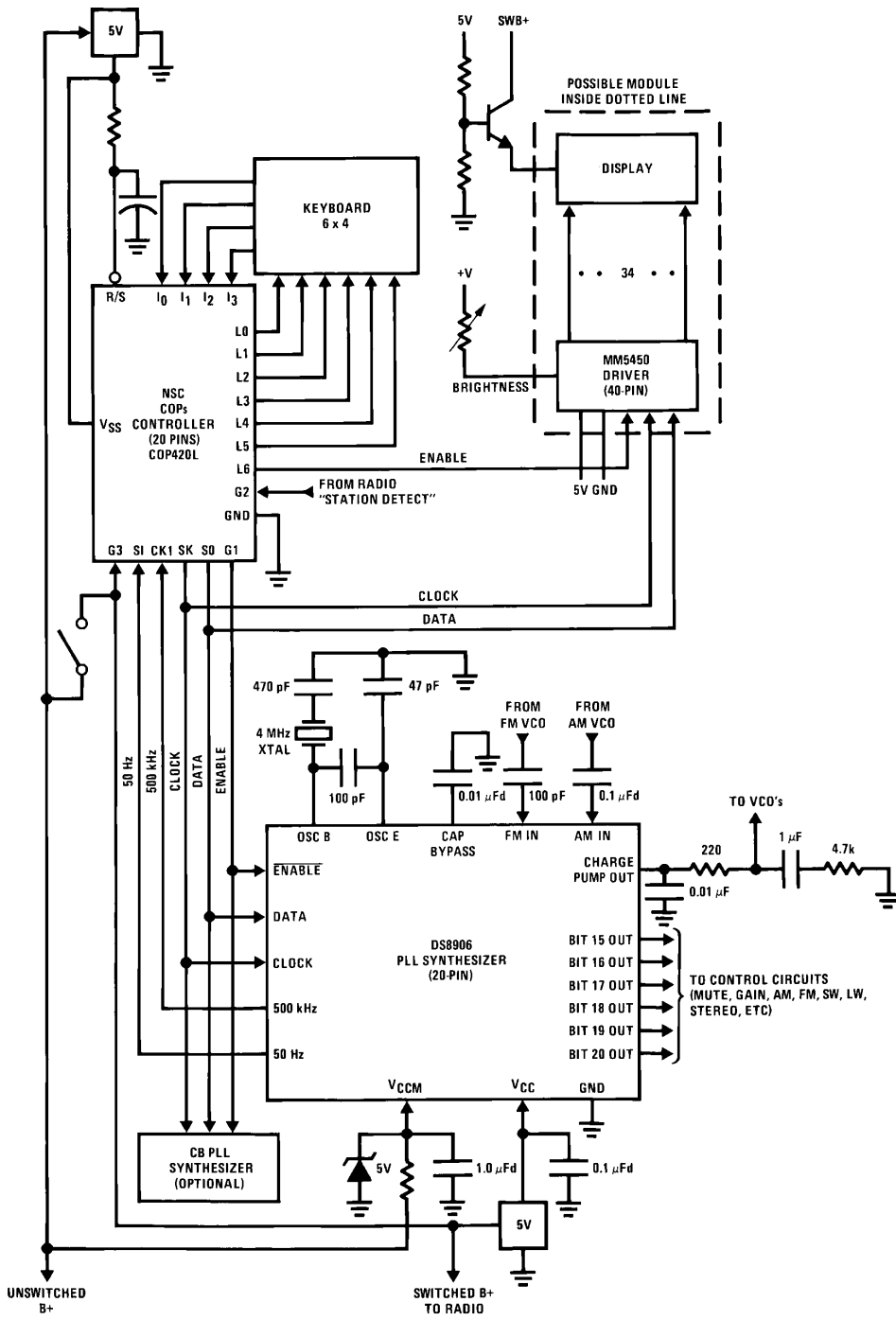

TL/F/5775-12

# Logic Diagram

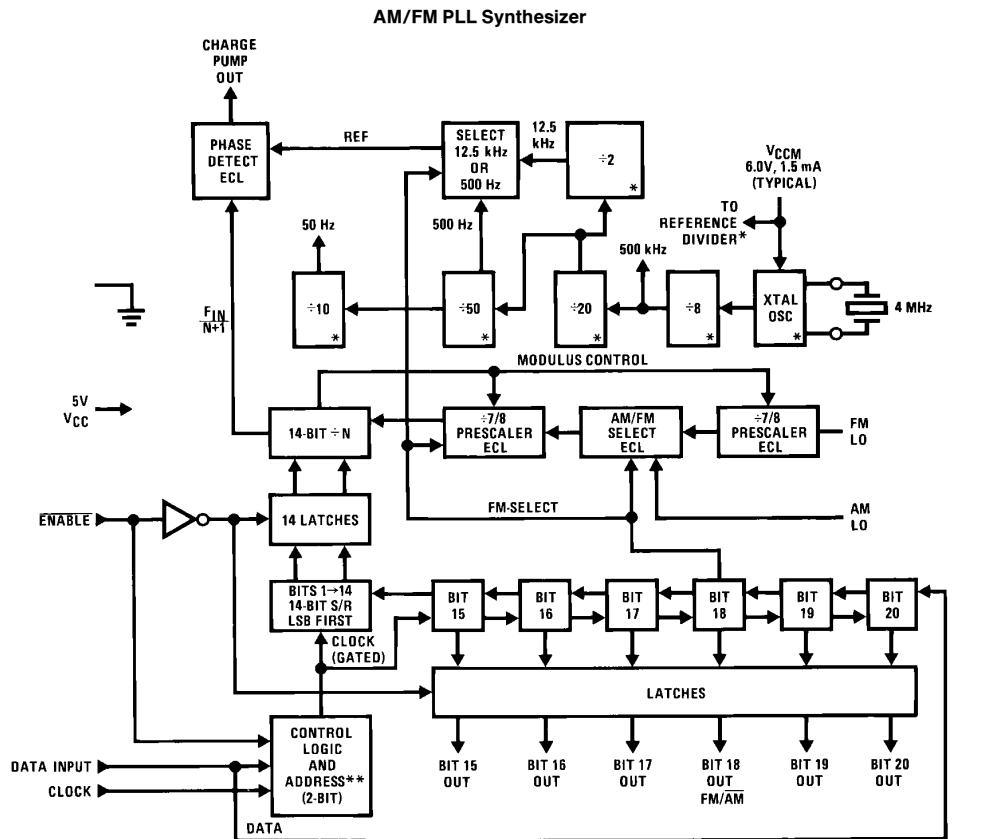

TL/F/5775-13

\*Sections operating from  $V_{CCM}$  supply

\*\*Address (1, 1)

**Physical Dimensions** inches (millimeters)

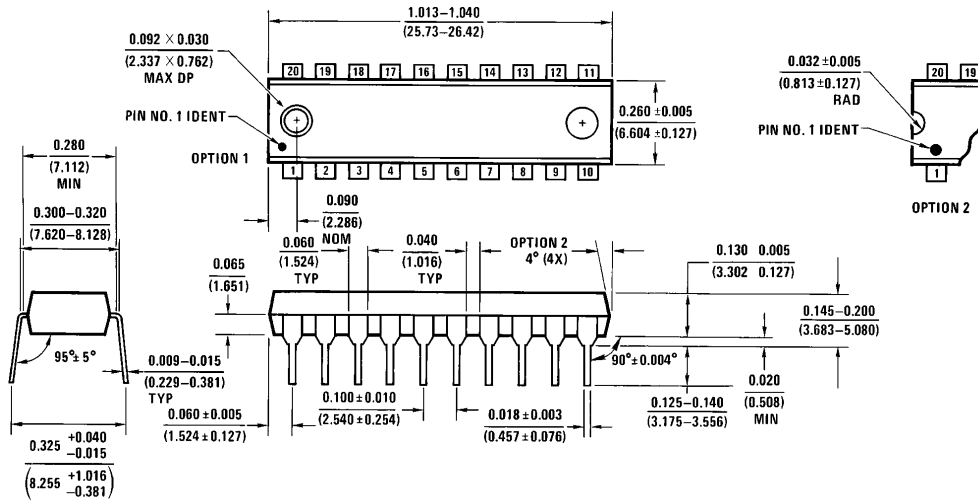

**Molded Dual-In-Line Package (N)**  
**Order Number DS8906N**  
**NS Package Number N20A**

N20A (REV G)

**LIFE SUPPORT POLICY**

NATIONAL'S PRODUCTS ARE NOT AUTHORIZED FOR USE AS CRITICAL COMPONENTS IN LIFE SUPPORT DEVICES OR SYSTEMS WITHOUT THE EXPRESS WRITTEN APPROVAL OF THE PRESIDENT OF NATIONAL SEMICONDUCTOR CORPORATION. As used herein:

1. Life support devices or systems are devices or systems which, (a) are intended for surgical implant into the body, or (b) support or sustain life, and whose failure to perform, when properly used in accordance with instructions for use provided in the labeling, can be reasonably expected to result in a significant injury to the user.
2. A critical component is any component of a life support device or system whose failure to perform can be reasonably expected to cause the failure of the life support device or system, or to affect its safety or effectiveness.



**National Semiconductor Corporation**  
 1111 West Bardin Road  
 Arlington, TX 76017  
 Tel: 1(800) 272-9959  
 Fax: 1(800) 737-7018

**National Semiconductor Europe**  
 Fax: (+49) 0-180-530 85 86  
 Email: onjwge@tevm2.nsc.com  
 Deutsch Tel: (+49) 0-180-530 85 85  
 English Tel: (+49) 0-180-532 78 32  
 Français Tel: (+49) 0-180-532 93 58  
 Italiano Tel: (+49) 0-180-534 16 80

**National Semiconductor Hong Kong Ltd.**  
 19th Floor, Straight Block,  
 Ocean Centre, 5 Canton Rd.  
 Tsimshatsui, Kowloon  
 Hong Kong  
 Tel: (852) 2737-1600  
 Fax: (852) 2736-9960

**National Semiconductor Japan Ltd.**  
 Tel: 81-043-299-2309  
 Fax: 81-043-299-2408

National does not assume any responsibility for use of any circuitry described, no circuit patent licenses are implied and National reserves the right at any time without notice to change said circuitry and specifications.

# National Semiconductor was acquired by Texas Instruments.

[http://www.ti.com/corp/docs/investor\\_relations/pr\\_09\\_23\\_2011\\_national\\_semiconductor.html](http://www.ti.com/corp/docs/investor_relations/pr_09_23_2011_national_semiconductor.html)

This file is the datasheet for the following electronic components:

DS8906 - <http://www.ti.com/product/ds8906?HQS=TI-null-null-dscatalog-df-pf-null-ww>



LittleDiode supplies new, hard to find or obsolete electronic components and semiconductors all over the world.

With over two million different components listed you are sure to find the part you need.

Feel free to visit us today at our online store:

[LittleDiode.com](http://LittleDiode.com)

Looking forward to providing you with the best possible service.