

NPN Silicon RF Transistor

BFQ 71

- For broadband amplifiers up to 2 GHz and fast non-saturated switches at collector currents from 1 mA to 20 mA.
- Hermetically sealed ceramic package.
- HiRel/Mil screening available.
- CECC-type available: CECC 50002/260.

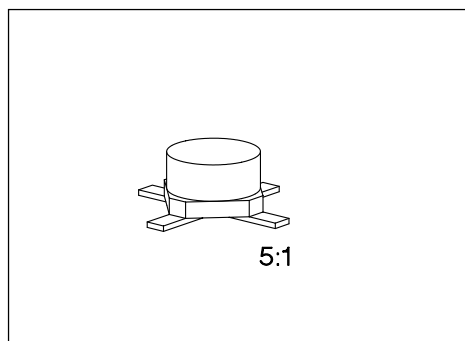

ESD: Electrostatic discharge sensitive device, observe handling precautions!

Type	Marking	Ordering Code (tape and reel)	Pin Configuration				Package ¹⁾
			1	2	3	4	
BFQ 71	71	Q62702-F775	B	E	C	E	Cerrec-X

Maximum Ratings

Parameter	Symbol	Values	Unit
Collector-emitter voltage	V_{CE0}	15	V
Collector-emitter voltage, $V_{BE} = 0$	V_{CES}	20	
Collector-base voltage	V_{CB0}	20	
Emitter-base voltage	V_{EB0}	2.5	
Collector current	I_C	30	mA
Base current	I_B	4	
Total power dissipation, $T_s \leq 103 \text{ }^\circ\text{C}^3)$	P_{tot}	300	mW
Junction temperature	T_j	175	$^\circ\text{C}$
Ambient temperature range	T_A	- 65 ... + 175	
Storage temperature range	T_{stg}	- 65 ... + 175	

Thermal Resistance

Junction - ambient ²⁾	$R_{th JA}$	≤ 320	K/W
Junction - soldering point ³⁾	$R_{th JS}$	≤ 240	

1) For detailed dimensions see chapter Package Outlines.

2) Package mounted on alumina 15 mm × 16.7 mm × 0.7 mm.

3) T_s is measured on the collector lead at the soldering point to the pcb.

Electrical Characteristics

at $T_A = 25\text{ °C}$, unless otherwise specified.

Parameter	Symbol	Values			Unit
		min.	typ.	max.	

DC Characteristics

Collector-emitter breakdown voltage $I_C = 1\text{ mA}, I_B = 0$	$V_{(BR)CE0}$	15	–	–	V
Collector-base cutoff current $V_{CB} = 10\text{ V}, I_E = 0$	I_{CB0}	–	–	50	nA
Emitter-base cutoff current $V_{EB} = 2\text{ V}, I_C = 0$	I_{EB0}	–	–	10	μA
DC current gain $I_C = 5\text{ mA}, V_{CE} = 6\text{ V}$ $I_C = 20\text{ mA}, V_{CE} = 6\text{ V}$	h_{FE}	40 40	90 100	250 –	–
Collector-emitter saturation voltage $I_C = 30\text{ mA}, I_B = 3\text{ mA}$	V_{CEsat}	–	0.16	0.4	V
Base-emitter voltage $I_C = 5\text{ mA}, V_{CE} = 6\text{ V}$	V_{BE}	–	0.78	–	

Electrical Characteristics

at $T_A = 25\text{ }^\circ\text{C}$, unless otherwise specified.

Parameter	Symbol	Values			Unit
		min.	typ.	max.	

AC Characteristics

Transition frequency $I_C = 5\text{ mA}$, $V_{CE} = 6\text{ V}$, $f = 200\text{ MHz}$ $I_C = 20\text{ mA}$, $V_{CE} = 6\text{ V}$, $f = 200\text{ MHz}$	f_t	– 4	4.2 5.2	– –	GHz
Collector-base capacitance $V_{CB} = 6\text{ V}$, $V_{BE} = v_{be} = 0$, $f = 1\text{ MHz}$	C_{cb}	–	0.46	0.6	pF
Collector-emitter capacitance $V_{CE} = 6\text{ V}$, $V_{BE} = v_{be} = 0$, $f = 1\text{ MHz}$	C_{ce}	–	0.4	–	
Input capacitance $V_{EB} = 0.5\text{ V}$, $I_C = i_c = 0$, $f = 1\text{ MHz}$	C_{ibo}	–	1.2	–	
Output capacitance $V_{CE} = 6\text{ V}$, $V_{BE} = v_{be} = 0$, $f = 1\text{ MHz}$	C_{obs}	–	0.86	1.2	
Noise figure $I_C = 5\text{ mA}$, $V_{CE} = 6\text{ V}$, $f = 10\text{ MHz}$, $Z_S = 75\text{ }\Omega$ $I_C = 2\text{ mA}$, $V_{CE} = 6\text{ V}$, $f = 800\text{ MHz}$, $Z_S = Z_{Sopt}$ $I_C = 3\text{ mA}$, $V_{CE} = 10\text{ V}$, $f = 2\text{ GHz}$, $Z_S = Z_{Sopt}$	F	– – –	1.4 1.5 3.2	2.2 3 –	dB
Power gain $I_C = 2\text{ mA}$, $V_{CE} = 6\text{ V}$, $f = 800\text{ MHz}$, $Z_S = Z_{Sopt}$, $Z_L = Z_{Lopt}$	G_{pe}	–	15	–	
Transducer gain $I_C = 20\text{ mA}$, $V_{CE} = 6\text{ V}$, $f = 1\text{ GHz}$, $Z_0 = 50\text{ }\Omega$	$ S_{21e} ^2$	–	13.4	–	
Linear output voltage two-tone intermodulation test $I_C = 15\text{ mA}$, $V_{CE} = 10\text{ V}$, $d_{IM} = 60\text{ dB}$, $f_1 = 806\text{ MHz}$, $f_2 = 810\text{ MHz}$, $Z_S = Z_L = 50\text{ }\Omega$	$V_{o1} = V_{o2}$	–	110	–	mV
Third order intercept point $I_C = 15\text{ mA}$, $V_{CE} = 10\text{ V}$, $f = 800\text{ MHz}$	IP_3	–	23.5	–	dBm

Total power dissipation $P_{tot} = f(T_A^*; T_S)$

*Package mounted on alumina

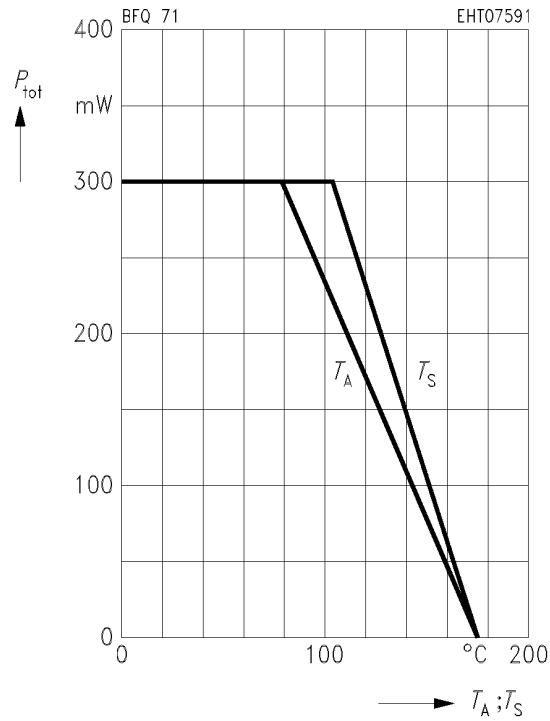

Transition frequency $f_T = f(I_C)$

$V_{CE} = 6\text{ V}, f = 200\text{ MHz}$

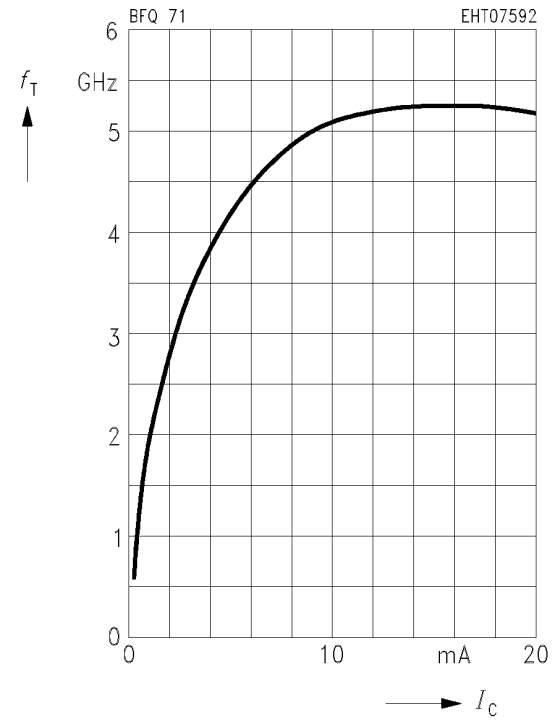

Collector-base capacitance $C_{cb} = f(V_{CB})$

$V_{BE} = v_{be} = 0, f = 1\text{ MHz}$

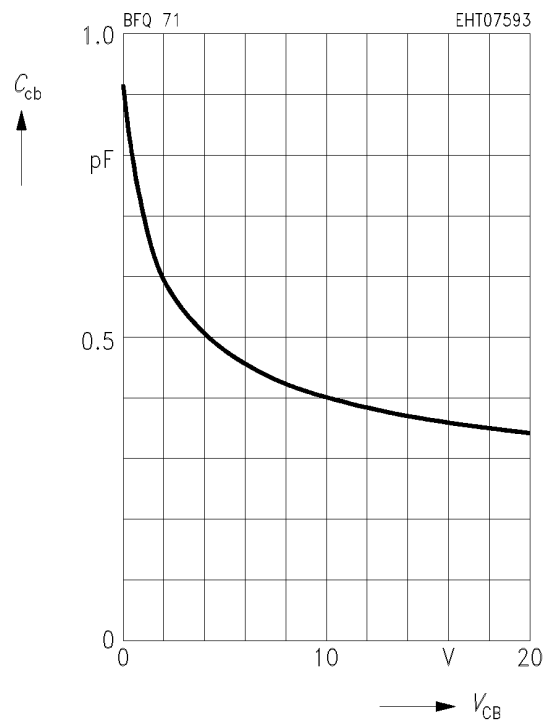

Common Emitter Noise Parameters

f	F_{min}	$G_p(F_{min})$	Γ_{opt}		R_N	N	$F_{50 \Omega}$	$G_p(F_{50 \Omega})$
GHz	dB	dB	MAG	ANG	Ω	-	dB	dB

$I_C = 2 \text{ mA}, V_{CE} = 6 \text{ V}, Z_0 = 50 \Omega$

0.01	1.1	-	(Z _s = 150 Ω)		-	-	1.6	-
------	-----	---	----------------------------------	--	---	---	-----	---

$I_C = 5 \text{ mA}, V_{CE} = 10 \text{ V}, Z_0 = 50 \Omega$

0.01	1.3	-	(Z _s = 100 Ω)		-	-	1.7	-
0.8	1.6	15.3	0.29	56	18.5	0.24	1.8	14.8
2.0	3.1	9	0.12	124.5	30	0.67	-	-

Noise figure $F = f(Z_s)$

$V_{CE} = 6 \text{ V}, f = 10 \text{ MHz}$

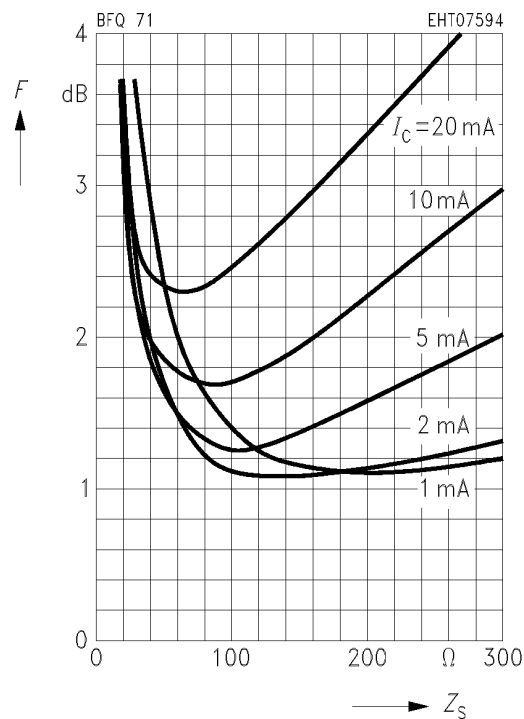

Circles of constant noise figure $F = f(Z_s)$ and available power gain $G_{av} = f(Z_s)$

$I_C = 5 \text{ mA}$, $V_{CE} = 10 \text{ V}$, $f = 800 \text{ MHz}$

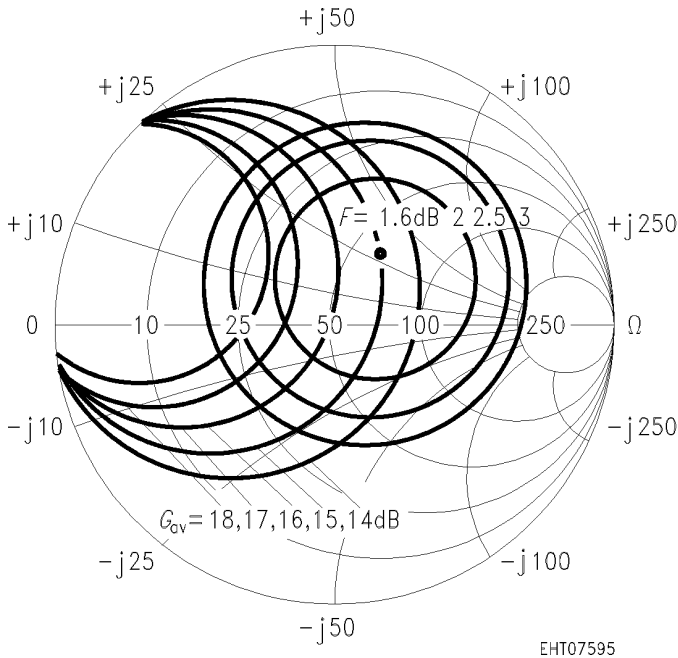

Noise figure $F = f(I_C)$ and Power gain $G = f(I_C)$

$V_{CE} = 10 \text{ V}$, $f = 800 \text{ MHz}$, $Z_{Lopt}(G)$

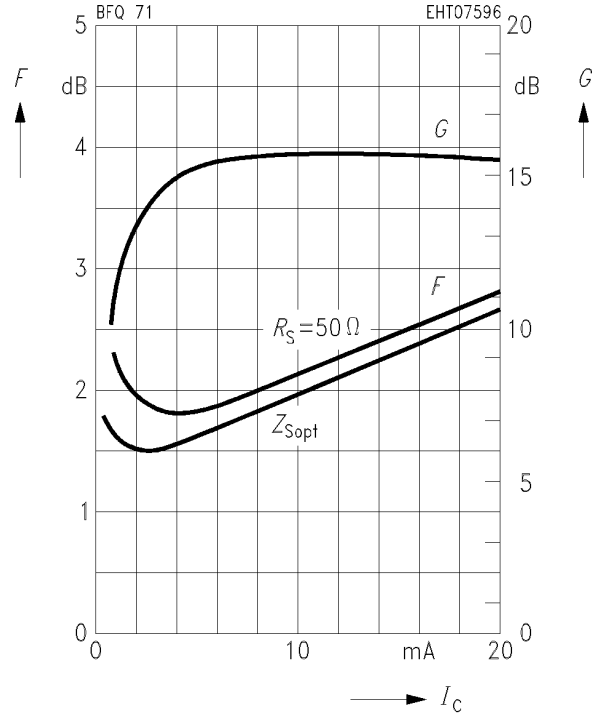

Circles of constant noise figure $F = f(Z_s)$ and available power gain $G_{av} = f(Z_s)$

$I_C = 5 \text{ mA}$, $V_{CE} = 10 \text{ V}$, $f = 2 \text{ GHz}$

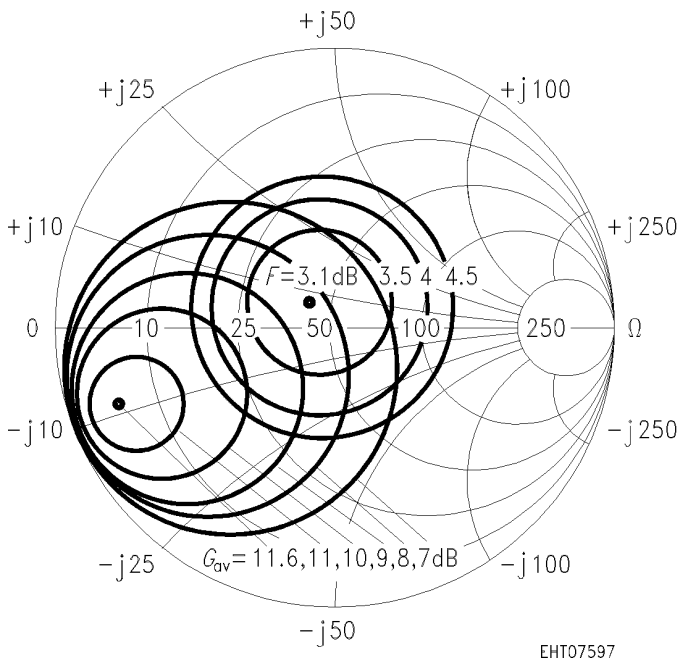

Noise figure $F = f(I_C)$ and Power gain $G = f(I_C)$

$V_{CE} = 10 \text{ V}$, $f = 2 \text{ GHz}$, $Z_{Lopt}(G)$

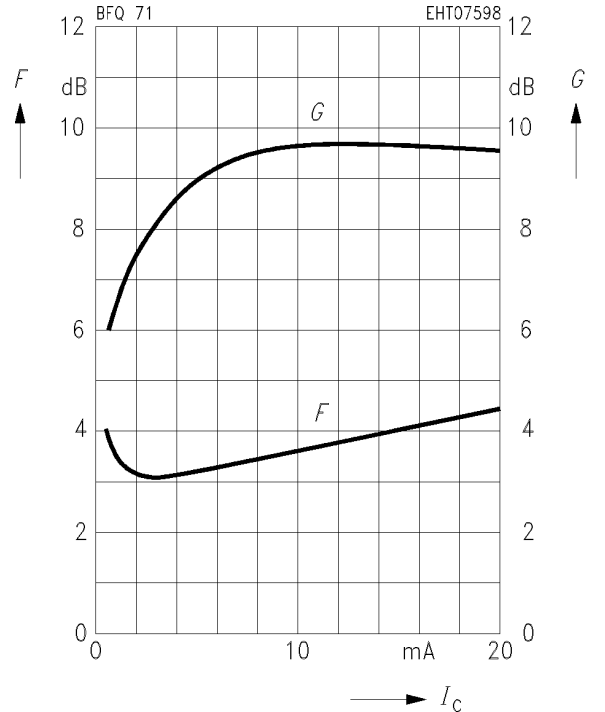

Common Emitter Power Gain

Power gain $G_{ms}, |S_{21e}|^2 = f(I_c)$

$V_{CE} = 6 \text{ V}, f = 200 \text{ MHz}, Z_0 = 50 \Omega$

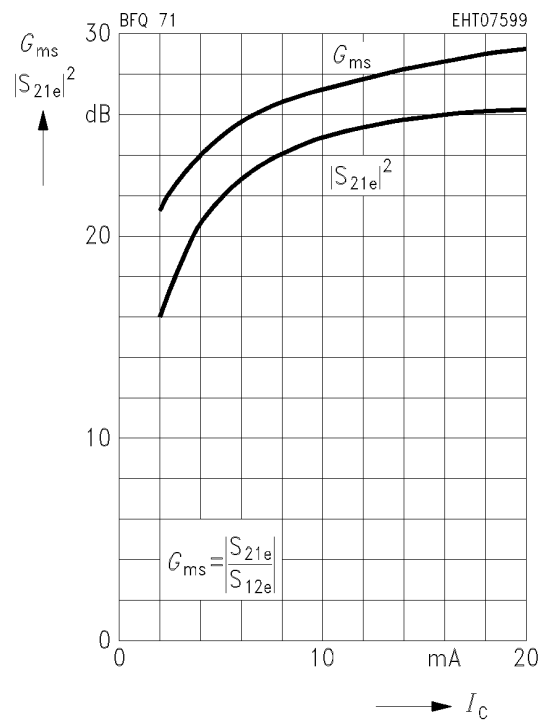

Power gain $G_{ms}, |S_{21e}|^2 = f(I_c)$

$V_{CE} = 6 \text{ V}, f = 500 \text{ MHz}, Z_0 = 50 \Omega$

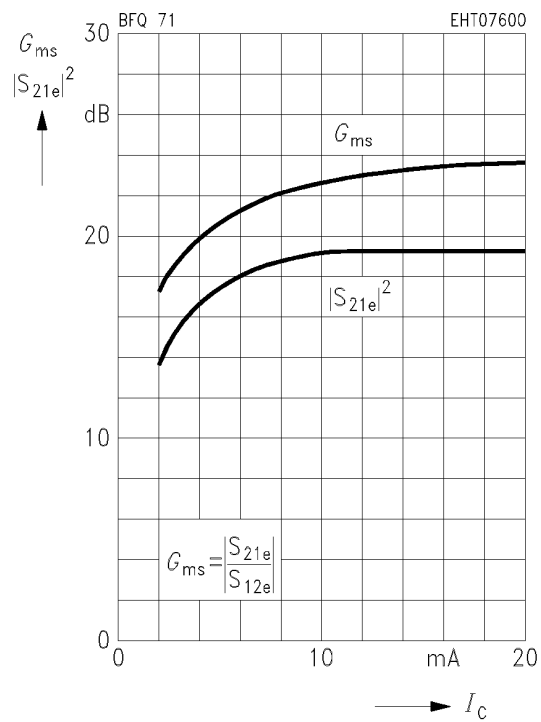

Power gain $G_{ms}, |S_{21e}|^2 = f(I_c)$

$V_{CE} = 6 \text{ V}, f = 800 \text{ MHz}, Z_0 = 50 \Omega$

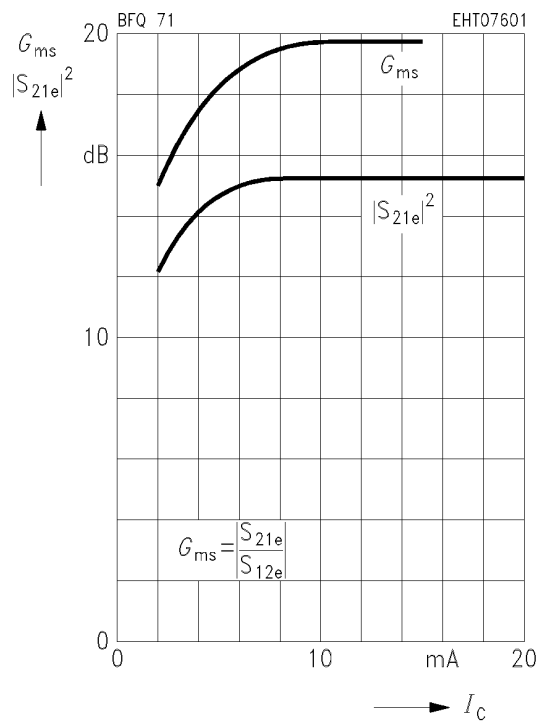

Power gain $G_{ma}, |S_{21e}|^2 = f(I_c)$

$V_{CE} = 6 \text{ V}, f = 2 \text{ GHz}, Z_0 = 50 \Omega$

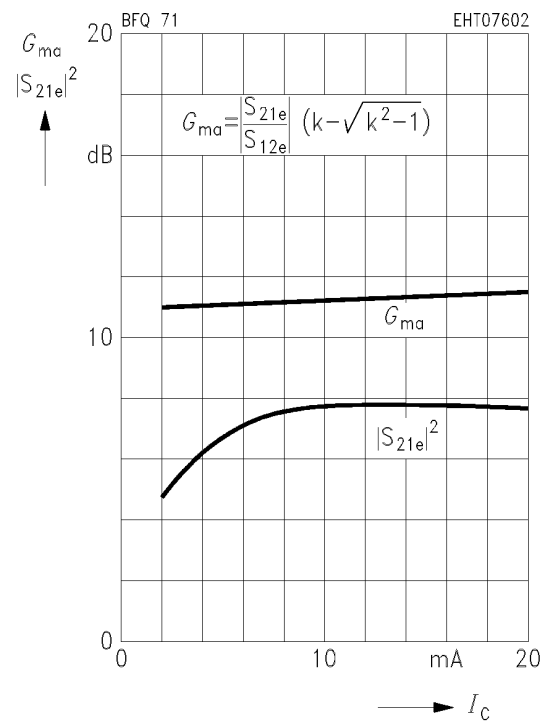

Power gain G_{ms} , $|S_{21e}|^2 = f(f)$
 $I_C = 2 \text{ mA}$, $V_{CE} = 6 \text{ V}$, $Z_0 = 50 \Omega$

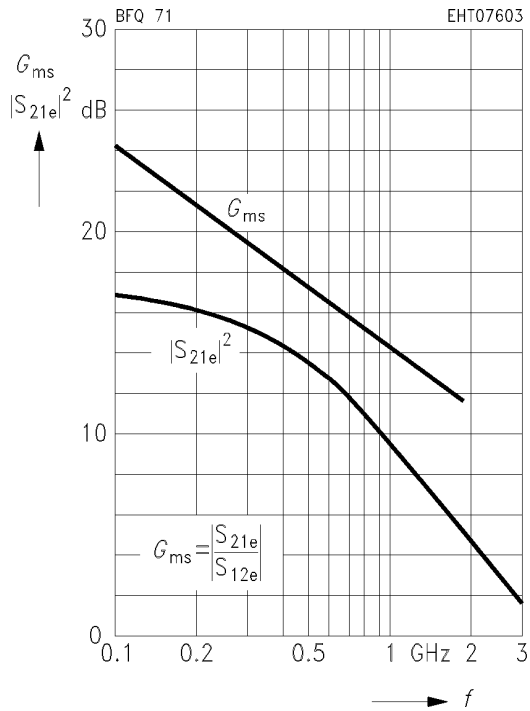

Power gain G_{ma} , G_{ms} , $|S_{21e}|^2 = f(f)$
 $I_C = 5 \text{ mA}$, $V_{CE} = 6 \text{ V}$, $Z_0 = 50 \Omega$

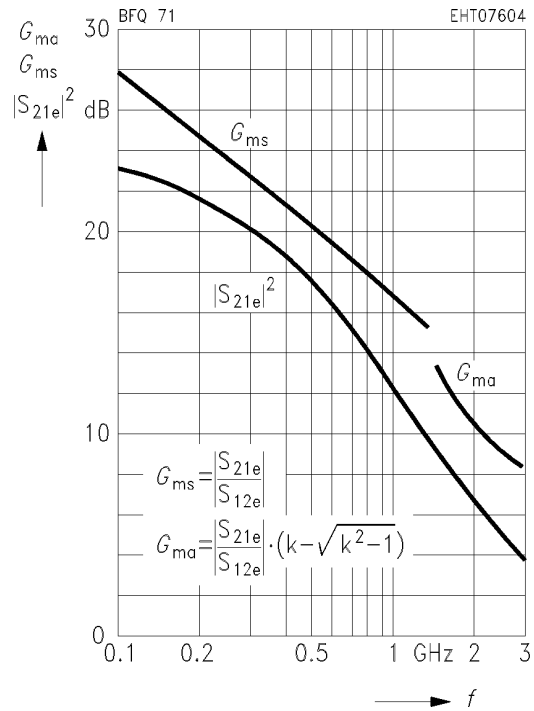

Power gain G_{ma} , G_{ms} , $|S_{21e}|^2 = f(f)$
 $I_C = 10 \text{ mA}$, $V_{CE} = 6 \text{ V}$, $Z_0 = 50 \Omega$

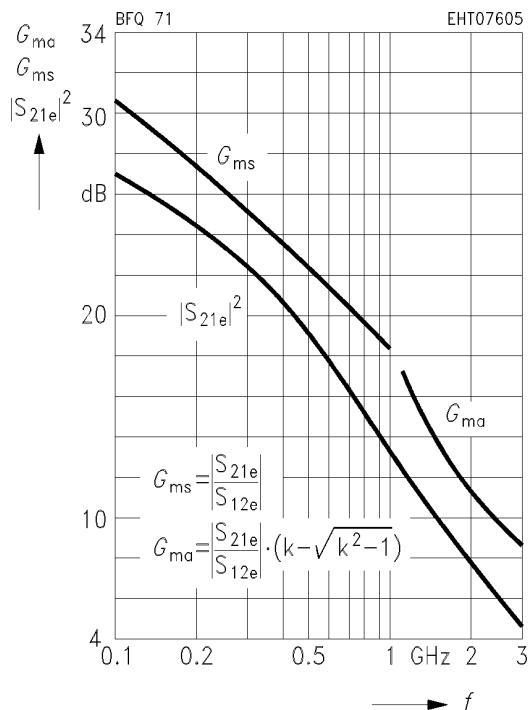

Power gain G_{ma} , G_{ms} , $|S_{21e}|^2 = f(f)$
 $I_C = 20 \text{ mA}$, $V_{CE} = 6 \text{ V}$, $Z_0 = 50 \Omega$

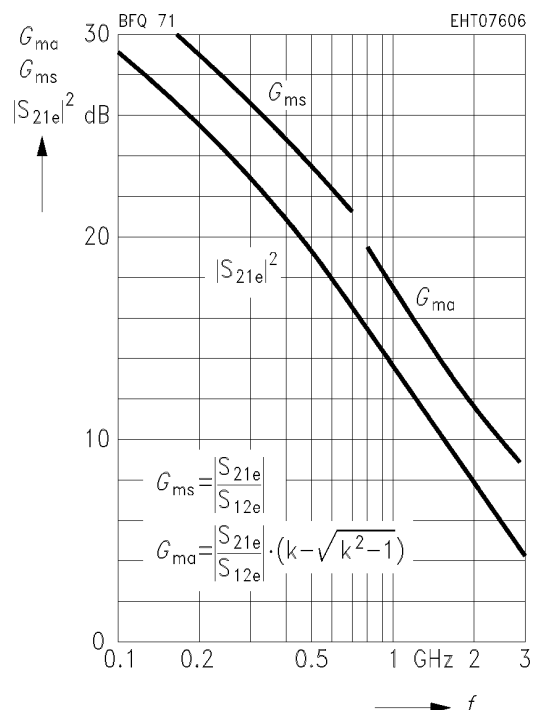

Common Emitter S Parameters

<i>f</i>	<i>S</i> ₁₁		<i>S</i> ₂₁		<i>S</i> ₁₂		<i>S</i> ₂₂		
	GHZ	MAG	ANG	MAG	ANG	MAG	ANG	MAG	ANG
<i>I</i> _C = 2 mA, <i>V</i> _{CE} = 6 V, <i>Z</i> ₀ = 50 Ω									
0.1	0.90	- 19	6.93	166	0.025	78	0.98	- 8	
0.2	0.87	- 37	6.45	152	0.048	68	0.94	- 16	
0.3	0.81	- 55	5.85	140	0.068	59	0.88	- 23	
0.4	0.77	- 71	5.41	129	0.082	51	0.82	- 28	
0.6	0.69	- 97	4.41	112	0.101	40	0.73	- 36	
0.8	0.64	- 118	3.64	98	0.112	33	0.65	- 41	
1.0	0.61	- 134	3.06	87	0.118	28	0.60	- 45	
1.2	0.59	- 147	2.64	79	0.121	25	0.57	- 49	
1.5	0.57	- 163	2.19	66	0.125	22	0.54	- 54	
1.8	0.57	- 176	1.87	56	0.129	20	0.52	- 60	
2.0	0.58	176	1.70	49	0.131	20	0.51	- 65	
2.5	0.59	159	1.41	34	0.138	20	0.49	- 78	
3.0	0.60	145	1.21	21	0.150	19	0.48	- 92	

*S*₁₁, *S*₂₂ = *f* (*f*)

*I*_C = 2 mA, *V*_{CE} = 6 V, *Z*₀ = 50 Ω

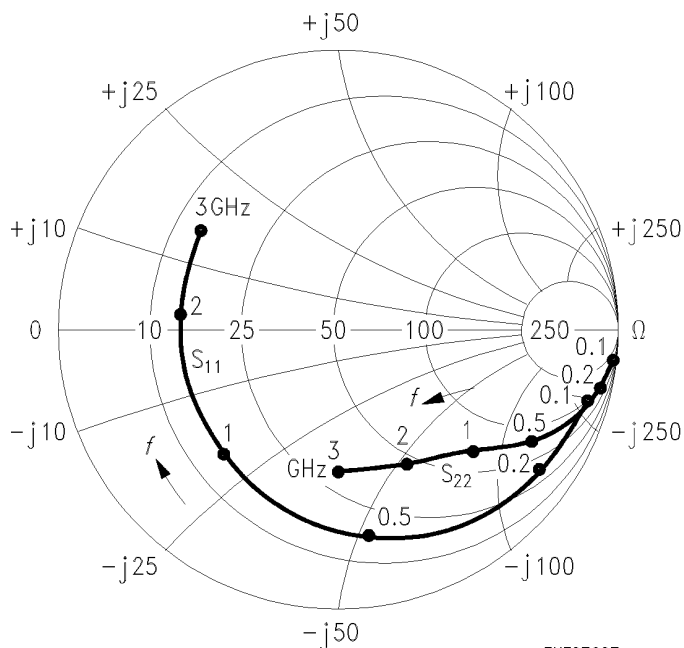

EHT07607

*S*₁₂, *S*₂₁ = *f* (*f*)

*I*_C = 2 mA, *V*_{CE} = 6 V, *Z*₀ = 50 Ω

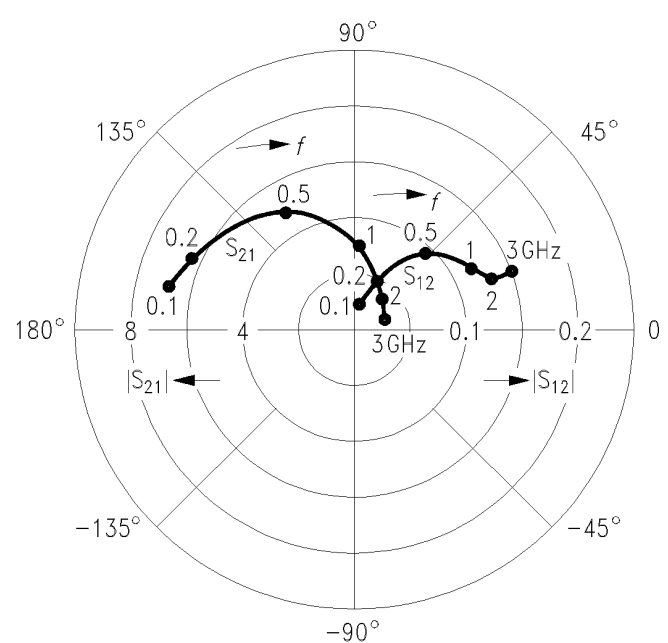

EHT07608

Common Emitter S Parameters (continued)

<i>f</i>	<i>S</i> ₁₁		<i>S</i> ₂₁		<i>S</i> ₁₂		<i>S</i> ₂₂	
	MAG	ANG	MAG	ANG	MAG	ANG	MAG	ANG
0.1	0.79	- 31	14.23	160	0.023	76	0.95	- 14
0.2	0.73	- 59	12.37	151	0.040	61	0.84	- 26
0.3	0.66	- 83	10.36	127	0.053	51	0.73	- 33
0.4	0.62	- 102	8.88	115	0.060	45	0.65	- 38
0.6	0.57	- 128	6.56	100	0.071	40	0.53	- 43
0.8	0.55	- 146	5.12	89	0.077	37	0.47	- 46
1.0	0.54	- 160	4.17	80	0.083	37	0.43	- 48
1.2	0.54	- 170	3.55	73	0.089	37	0.40	- 51
1.5	0.54	178	2.89	63	0.099	37	0.38	- 55
1.8	0.54	168	2.43	54	0.110	37	0.37	- 61
2.0	0.56	162	2.20	48	0.117	36	0.36	- 65
2.5	0.57	148	1.81	35	0.137	35	0.34	- 78
3.0	0.59	136	1.55	23	0.158	32	0.34	- 92

*I*_C = 5 mA, *V*_{CE} = 6 V, *Z*₀ = 50 Ω

*S*₁₁, *S*₂₂ = *f* (*f*)

*I*_C = 5 mA, *V*_{CE} = 6 V, *Z*₀ = 50 Ω

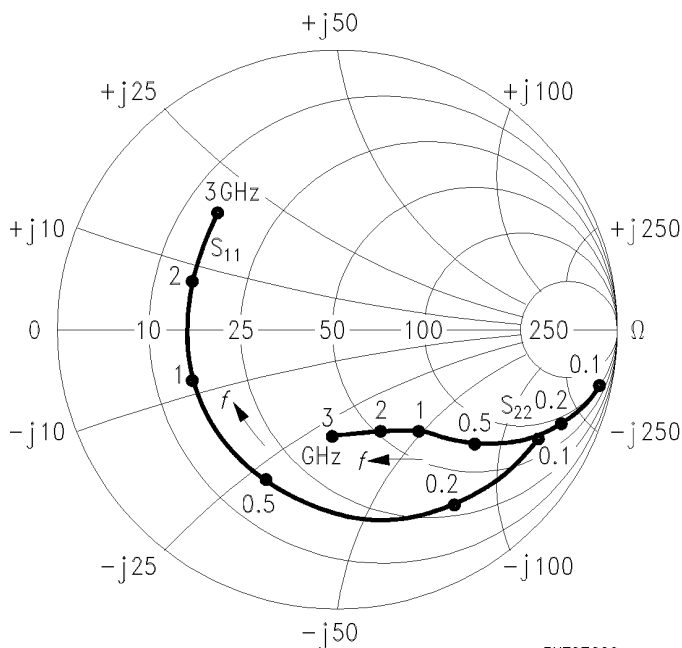

EHT07609

*S*₁₂, *S*₂₁ = *f* (*f*)

*I*_C = 5 mA, *V*_{CE} = 6 V, *Z*₀ = 50 Ω

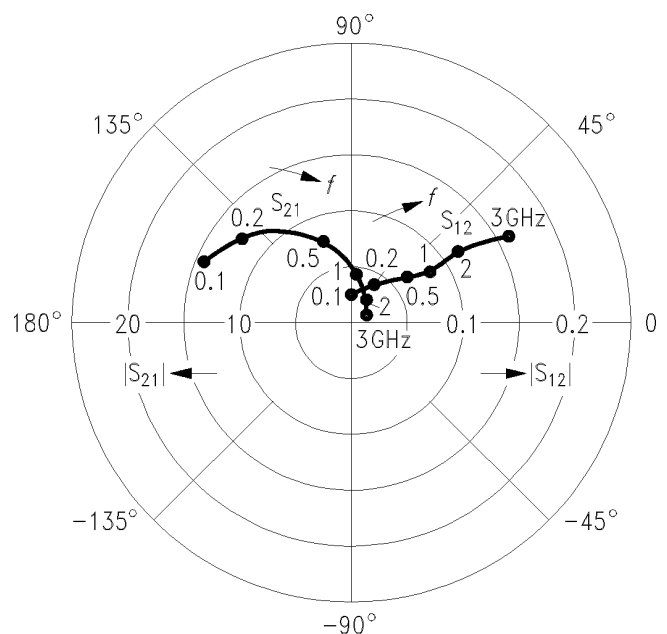

EHT07610

Common Emitter S Parameters (continued)

<i>f</i>	<i>S</i> ₁₁		<i>S</i> ₂₁		<i>S</i> ₁₂		<i>S</i> ₂₂	
	MAG	ANG	MAG	ANG	MAG	ANG	MAG	ANG
0.1	0.68	- 47	22.06	152	0.020	70	0.90	- 20
0.2	0.60	- 85	17.31	130	0.032	56	0.73	- 33
0.3	0.55	- 111	13.39	116	0.040	49	0.59	- 39
0.4	0.55	- 128	10.84	106	0.045	46	0.51	- 42
0.6	0.53	- 150	7.60	93	0.053	46	0.41	- 44
0.8	0.53	- 164	5.80	83	0.061	46	0.37	- 46
1.0	0.53	- 174	4.67	76	0.069	47	0.34	- 47
1.2	0.53	178	3.95	70	0.078	48	0.32	- 49
1.5	0.53	168	3.19	60	0.091	48	0.31	- 53
1.8	0.54	160	2.67	52	0.106	47	0.31	- 59
2.0	0.56	155	2.42	47	0.114	46	0.30	- 63
2.5	0.58	143	1.99	34	0.138	43	0.28	- 76
3.0	0.60	132	1.69	23	0.163	38	0.28	- 91

$I_C = 10 \text{ mA}, V_{CE} = 6 \text{ V}, Z_0 = 50 \Omega$

*S*₁₁, *S*₂₂ = *f* (*f*)

$I_C = 10 \text{ mA}, V_{CE} = 6 \text{ V}, Z_0 = 50 \Omega$

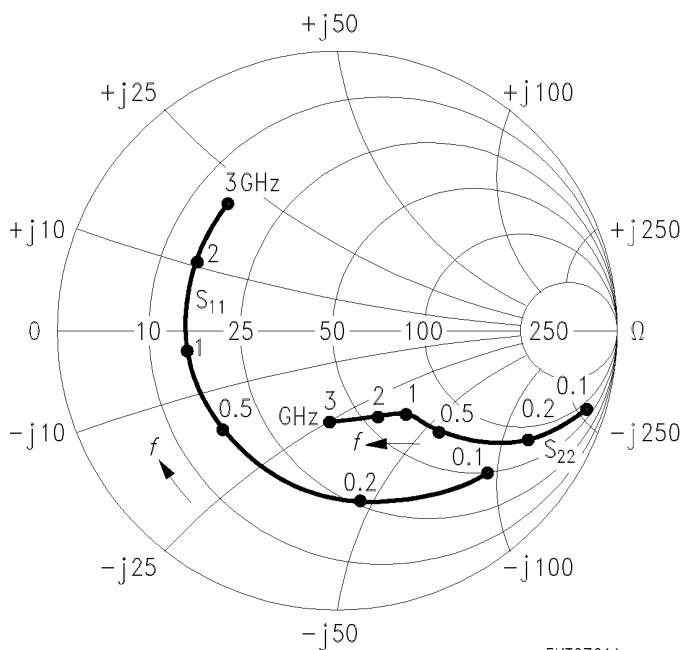

EHT07611

*S*₁₂, *S*₂₁ = *f* (*f*)

$I_C = 10 \text{ mA}, V_{CE} = 6 \text{ V}, Z_0 = 50 \Omega$

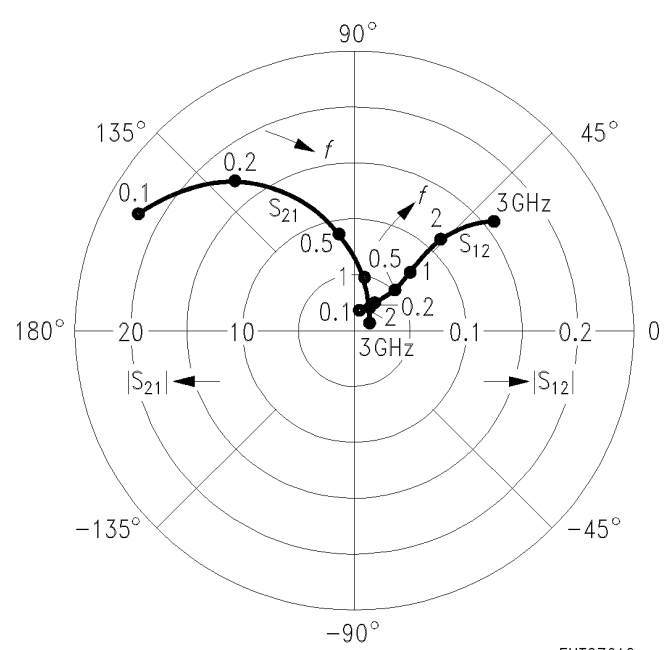

EHT07612

Common Emitter S Parameters (continued)

<i>f</i>	<i>S</i> ₁₁		<i>S</i> ₂₁		<i>S</i> ₁₂		<i>S</i> ₂₂		
	GHZ	MAG	ANG	MAG	ANG	MAG	ANG	MAG	ANG
<i>I</i> _C = 15 mA, <i>V</i> _{CE} = 6 V, <i>Z</i> ₀ = 50 Ω									
0.1	0.56	- 57	25.74	145	0.018	69	0.85	- 23	
0.2	0.47	- 96	18.17	122	0.028	58	0.65	- 32	
0.3	0.42	- 121	13.28	109	0.035	56	0.54	- 35	
0.4	0.42	- 137	10.48	100	0.042	57	0.47	- 35	
0.6	0.41	- 156	7.19	89	0.054	59	0.41	- 36	
0.8	0.40	- 168	5.46	81	0.068	60	0.39	- 37	
1.0	0.41	- 177	4.39	74	0.082	60	0.37	- 39	
1.2	0.41	176	3.71	68	0.096	60	0.36	- 41	
1.5	0.41	169	3.01	59	0.118	58	0.35	- 45	
1.8	0.43	161	2.53	52	0.142	56	0.35	- 52	
2.0	0.44	156	2.31	47	0.158	53	0.34	- 57	
2.5	0.46	147	1.91	35	0.204	47	0.33	- 70	
3.0	0.50	137	1.65	24	0.255	38	0.32	- 88	

*S*₁₁, *S*₂₂ = *f* (*f*)

*I*_C = 15 mA, *V*_{CE} = 6 V, *Z*₀ = 50 Ω

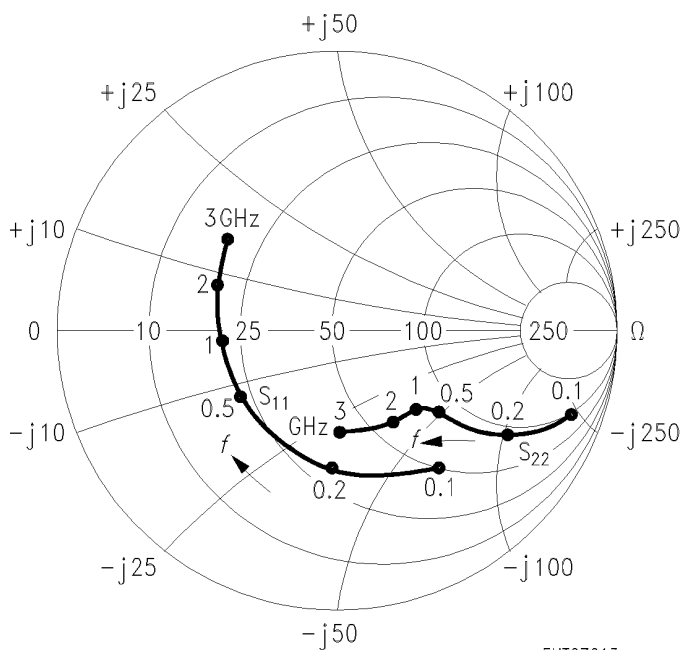

EHT07613

*S*₁₂, *S*₂₁ = *f* (*f*)

*I*_C = 15 mA, *V*_{CE} = 6 V, *Z*₀ = 50 Ω

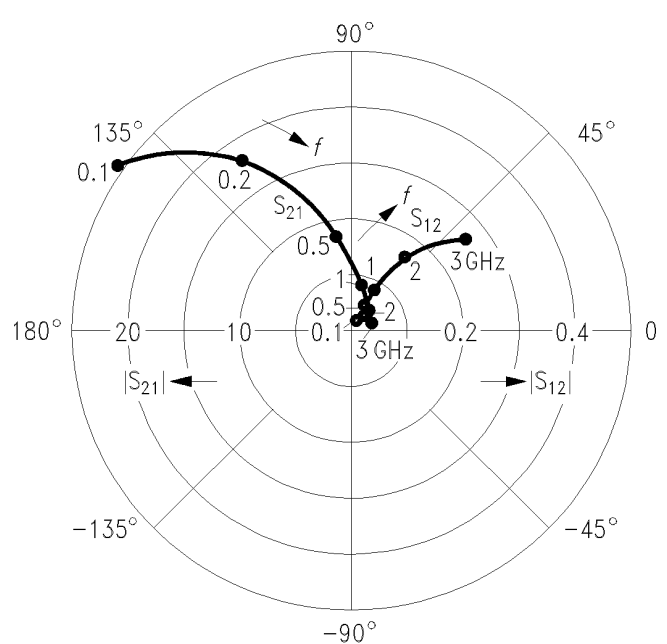

EHT07614

Common Emitter S Parameters (continued)

<i>f</i>	<i>S</i> ₁₁		<i>S</i> ₂₁		<i>S</i> ₁₂		<i>S</i> ₂₂	
	MAG	ANG	MAG	ANG	MAG	ANG	MAG	ANG
GHz								
<i>I</i> _C = 20 mA, <i>V</i> _{CE} = 6 V, <i>Z</i> ₀ = 50 Ω								
0.1	0.54	- 71	29.35	142	0.016	66	0.82	- 25
0.2	0.52	- 114	20.19	119	0.025	52	0.60	- 36
0.3	0.51	- 137	14.58	106	0.030	51	0.48	- 39
0.4	0.52	- 150	11.40	98	0.034	51	0.42	- 39
0.6	0.52	- 166	7.77	87	0.043	54	0.36	- 38
0.8	0.53	- 176	5.86	79	0.053	56	0.34	- 39
1.0	0.54	176	4.69	73	0.062	56	0.32	- 41
1.2	0.54	170	3.96	66	0.072	56	0.31	- 43
1.5	0.54	161	3.19	57	0.087	55	0.30	- 47
1.8	0.55	155	2.66	50	0.102	53	0.30	- 54
2.0	0.58	150	2.41	45	0.112	52	0.30	- 59
2.5	0.59	140	1.97	32	0.137	48	0.28	- 72
3.0	0.62	130	1.68	21	0.162	42	0.28	- 87

*S*₁₁, *S*₂₂ = *f* (*f*)

*I*_C = 20 mA, *V*_{CE} = 6 V, *Z*₀ = 50 Ω

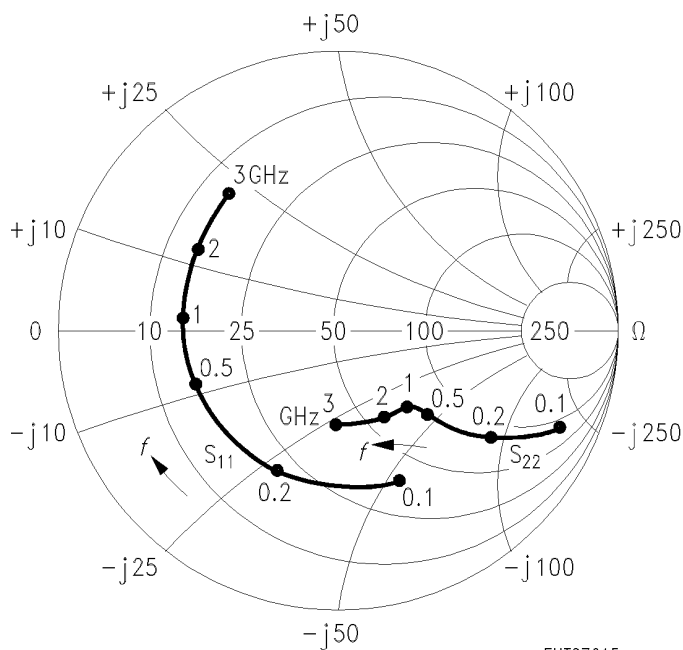

EHT07615

*S*₁₂, *S*₂₁ = *f* (*f*)

*I*_C = 20 mA, *V*_{CE} = 6 V, *Z*₀ = 50 Ω

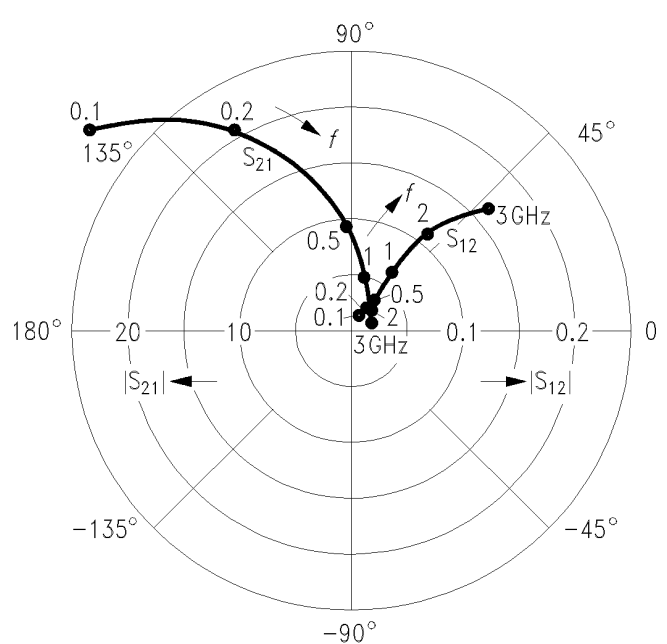

EHT07616

Common Emitter S Parameters (continued)

<i>f</i>	<i>S</i> ₁₁		<i>S</i> ₂₁		<i>S</i> ₁₂		<i>S</i> ₂₂	
	MAG	ANG	MAG	ANG	MAG	ANG	MAG	ANG
GHz								
<i>I</i> _C = 2 mA, <i>V</i> _{CE} = 10 V, <i>Z</i> ₀ = 50 Ω								
0.1	0.91	- 17	7.02	166	0.021	78	0.98	- 7
0.2	0.87	- 36	6.57	153	0.042	69	0.95	- 14
0.3	0.82	- 53	5.98	141	0.060	60	0.90	- 20
0.4	0.78	- 69	5.01	130	0.073	53	0.84	- 25
0.6	0.70	- 94	4.54	113	0.090	42	0.75	- 33
0.8	0.64	- 115	3.76	100	0.100	35	0.69	- 38
1.0	0.60	- 132	3.17	89	0.106	30	0.64	- 41
1.2	0.58	- 145	2.74	80	0.109	27	0.61	- 45
1.5	0.56	- 161	2.28	68	0.113	24	0.58	- 50
1.8	0.56	- 174	1.94	57	0.118	23	0.56	- 55
2.0	0.57	177	1.77	51	0.120	23	0.55	- 60
2.5	0.58	160	1.47	36	0.127	23	0.53	- 72
3.0	0.59	146	1.26	22	0.140	23	0.52	- 85

*S*₁₁, *S*₂₂ = *f* (*f*)

*I*_C = 2 mA, *V*_{CE} = 10 V, *Z*₀ = 50 Ω

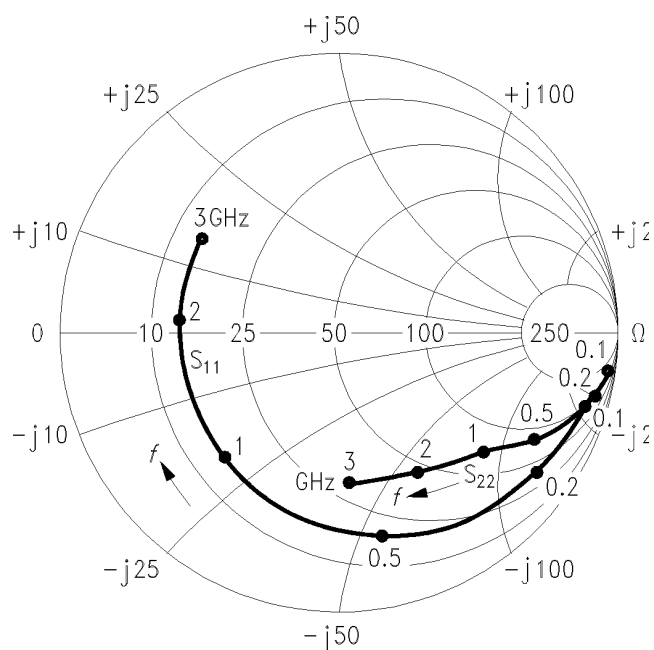

EHT07617

*S*₁₂, *S*₂₁ = *f* (*f*)

*I*_C = 2 mA, *V*_{CE} = 10 V, *Z*₀ = 50 Ω

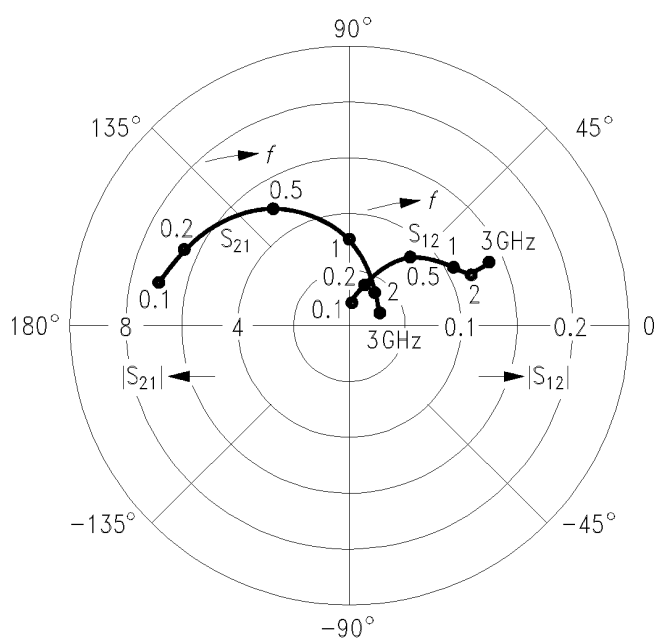

EHT07618

Common Emitter S Parameters (continued)

<i>f</i>	<i>S</i> ₁₁		<i>S</i> ₂₁		<i>S</i> ₁₂		<i>S</i> ₂₂	
	MAG	ANG	MAG	ANG	MAG	ANG	MAG	ANG
0.1	0.80	- 28	14.24	160	0.020	71	0.95	- 13
0.2	0.73	- 57	12.50	142	0.036	61	0.86	- 23
0.3	0.67	- 79	10.55	128	0.047	53	0.76	- 29
0.4	0.63	- 98	9.10	117	0.055	47	0.68	- 34
0.6	0.57	- 125	6.78	101	0.064	41	0.58	- 38
0.8	0.54	- 143	5.31	90	0.071	39	0.52	- 41
1.0	0.53	- 157	4.33	81	0.076	38	0.48	- 43
1.2	0.52	- 168	3.69	74	0.082	38	0.46	- 45
1.5	0.52	180	3.00	63	0.091	39	0.44	- 49
1.8	0.53	170	2.52	54	0.101	39	0.43	- 55
2.0	0.54	163	2.29	49	0.108	39	0.42	- 59
2.5	0.56	150	1.89	36	0.127	38	0.40	- 70
3.0	0.58	137	1.61	23	0.148	35	0.40	- 84

*I*_C = 5 mA, *V*_{CE} = 10 V, *Z*₀ = 50 Ω

*S*₁₁, *S*₂₂ = *f* (*f*)

*I*_C = 5 mA, *V*_{CE} = 10 V, *Z*₀ = 50 Ω

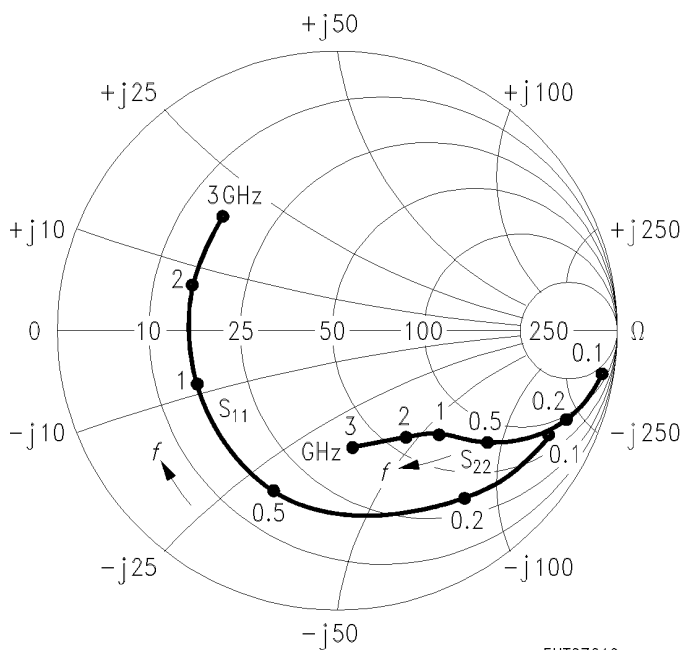

EHT07619

*S*₁₂, *S*₂₁ = *f* (*f*)

*I*_C = 5 mA, *V*_{CE} = 10 V, *Z*₀ = 50 Ω

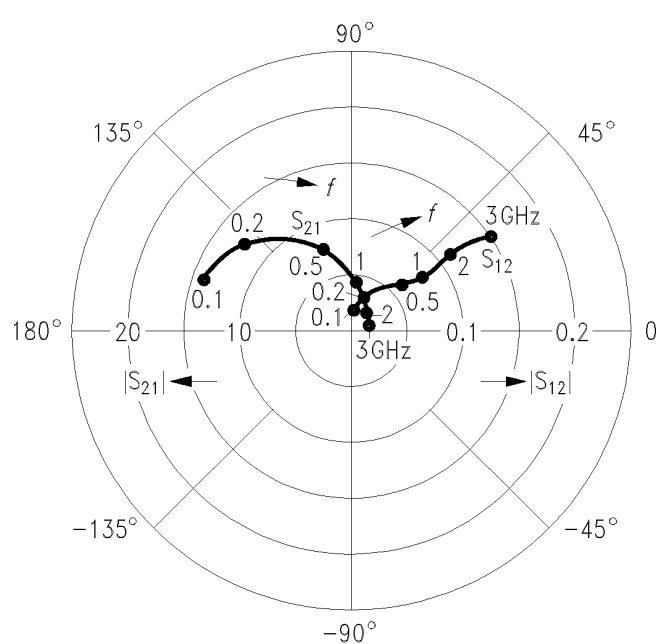

EHT07620

Common Emitter S Parameters (continued)

<i>f</i>	<i>S</i> ₁₁		<i>S</i> ₂₁		<i>S</i> ₁₂		<i>S</i> ₂₂	
	MAG	ANG	MAG	ANG	MAG	ANG	MAG	ANG
0.1	0.68	- 43	21.82	153	0.018	71	0.91	- 17
0.2	0.60	- 78	17.39	131	0.030	58	0.76	- 29
0.3	0.56	- 105	13.60	117	0.037	50	0.64	- 34
0.4	0.54	- 123	11.10	107	0.042	47	0.56	- 36
0.6	0.51	- 146	7.83	94	0.050	46	0.47	- 38
0.8	0.51	- 161	5.99	84	0.057	47	0.43	- 39
1.0	0.51	- 171	4.83	77	0.064	48	0.41	- 41
1.2	0.51	180	4.08	70	0.072	49	0.39	- 43
1.5	0.51	170	3.30	61	0.084	49	0.38	- 48
1.8	0.52	162	2.77	53	0.098	48	0.38	- 52
2.0	0.54	156	2.51	48	0.106	47	0.37	- 56
2.5	0.56	145	2.06	35	0.129	45	0.35	- 67
3.0	0.58	134	1.75	23	0.152	40	0.35	- 81

*I*_C = 10 mA, *V*_{CE} = 10 V, *Z*₀ = 50 Ω

*S*₁₁, *S*₂₂ = *f* (*f*)

*I*_C = 10 mA, *V*_{CE} = 10 V, *Z*₀ = 50 Ω

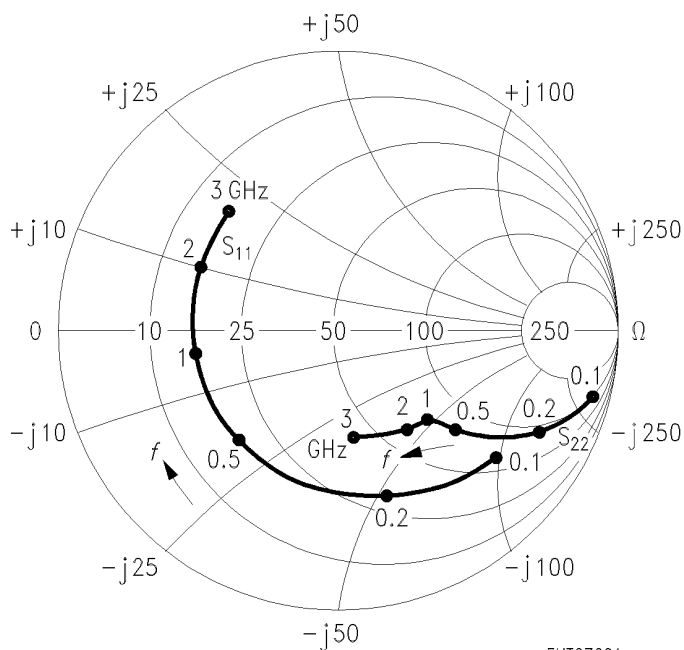

EHT07621

*S*₁₂, *S*₂₁ = *f* (*f*)

*I*_C = 10 mA, *V*_{CE} = 10 V, *Z*₀ = 50 Ω

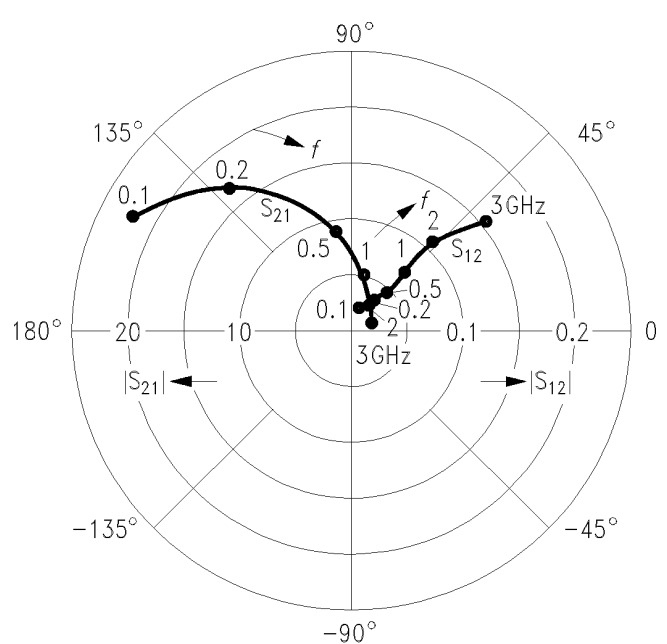

EHT07622

Common Emitter S Parameters (continued)

<i>f</i>	<i>S</i> ₁₁		<i>S</i> ₂₁		<i>S</i> ₁₂		<i>S</i> ₂₂	
	MAG	ANG	MAG	ANG	MAG	ANG	MAG	ANG
0.1	0.62	- 55	26.35	148	0.017	69	0.88	- 20
0.2	0.55	- 94	19.54	125	0.026	55	0.69	- 31
0.3	0.52	- 119	14.64	112	0.031	50	0.57	- 34
0.4	0.51	- 136	11.66	102	0.036	50	0.50	- 35
0.6	0.50	- 156	8.06	90	0.044	51	0.44	- 35
0.8	0.50	- 169	6.12	82	0.052	52	0.41	- 36
1.0	0.51	- 178	4.91	75	0.061	53	0.39	- 38
1.2	0.51	175	4.15	68	0.069	54	0.38	- 40
1.5	0.51	166	3.35	59	0.082	53	0.37	- 44
1.8	0.53	158	2.80	51	0.097	52	0.37	- 50
2.0	0.54	153	2.53	47	0.106	51	0.36	- 54
2.5	0.57	143	2.07	34	0.129	48	0.34	- 65
3.0	0.59	132	1.77	23	0.153	43	0.34	- 80

*I*_C = 15 mA, *V*_{CE} = 10 V, *Z*₀ = 50 Ω

*S*₁₁, *S*₂₂ = *f* (*f*)

*I*_C = 15 mA, *V*_{CE} = 10 V, *Z*₀ = 50 Ω

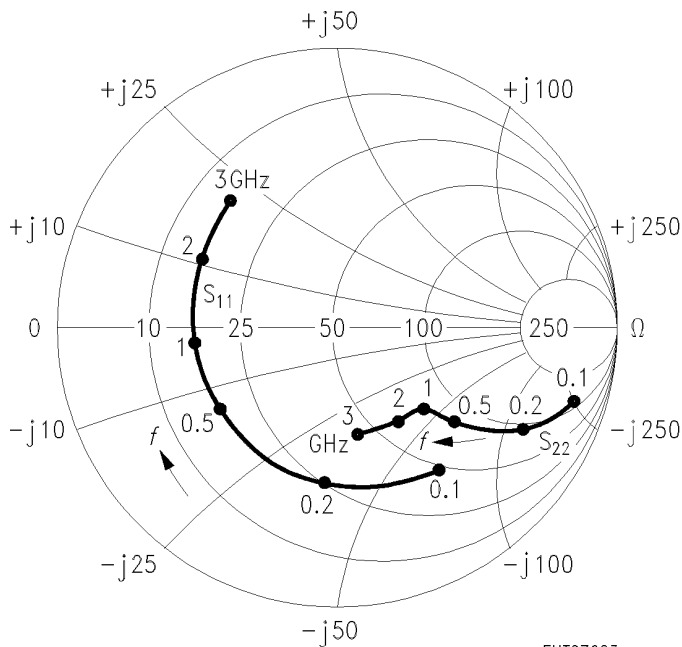

EHT07623

*S*₁₂, *S*₂₁ = *f* (*f*)

*I*_C = 15 mA, *V*_{CE} = 10 V, *Z*₀ = 50 Ω

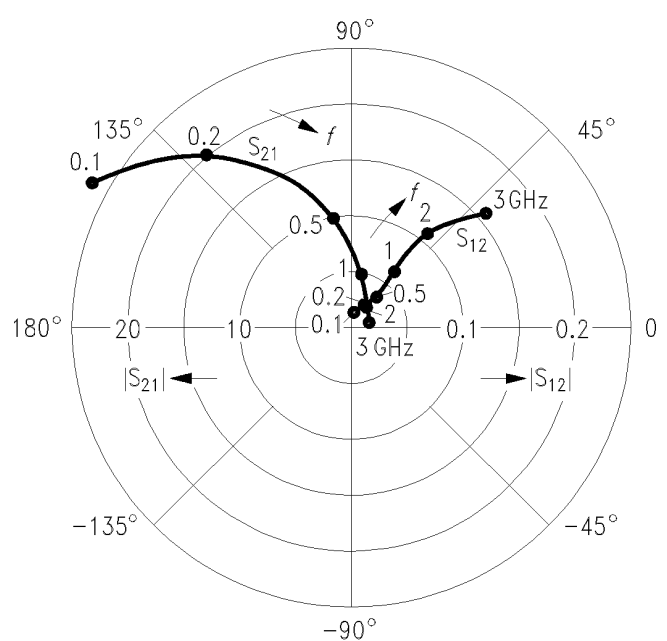

EHT07624

Common Emitter S Parameters (continued)

<i>f</i>	<i>S</i> ₁₁		<i>S</i> ₂₁		<i>S</i> ₁₂		<i>S</i> ₂₂	
	MAG	ANG	MAG	ANG	MAG	ANG	MAG	ANG
GHz								
<i>I</i> _C = 20 mA, <i>V</i> _{CE} = 10 V, <i>Z</i> ₀ = 50 Ω								
0.1	0.57	- 63	28.86	144	0.015	65	0.84	- 21
0.2	0.52	- 106	20.30	121	0.024	54	0.65	- 30
0.3	0.50	- 130	14.82	108	0.029	50	0.54	- 32
0.4	0.51	- 144	11.65	99	0.033	52	0.49	- 32
0.6	0.50	- 162	7.97	88	0.041	54	0.43	- 32
0.8	0.51	- 173	6.02	80	0.050	56	0.41	- 33
1.0	0.52	179	4.83	73	0.058	56	0.40	- 35
1.2	0.52	172	4.08	67	0.068	57	0.38	- 38
1.5	0.52	163	3.29	58	0.081	56	0.38	- 42
1.8	0.53	156	2.74	50	0.096	54	0.38	- 48
2.0	0.55	152	2.49	46	0.104	53	0.37	- 53
2.5	0.57	141	2.04	33	0.128	50	0.36	- 64
3.0	0.60	131	1.73	22	0.152	44	0.36	- 79

*S*₁₁, *S*₂₂ = *f* (*f*)

*I*_C = 20 mA, *V*_{CE} = 10 V, *Z*₀ = 50 Ω

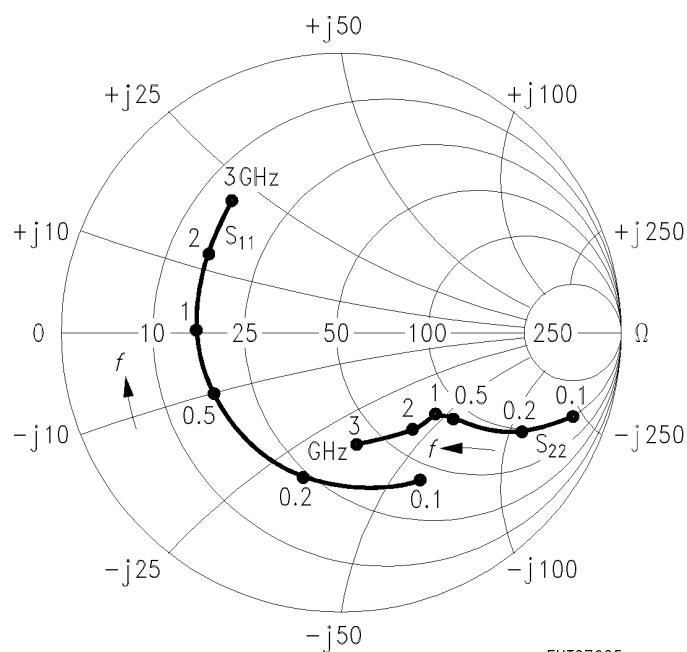

EHT07625

*S*₁₂, *S*₂₁ = *f* (*f*)

*I*_C = 20 mA, *V*_{CE} = 10 V, *Z*₀ = 50 Ω

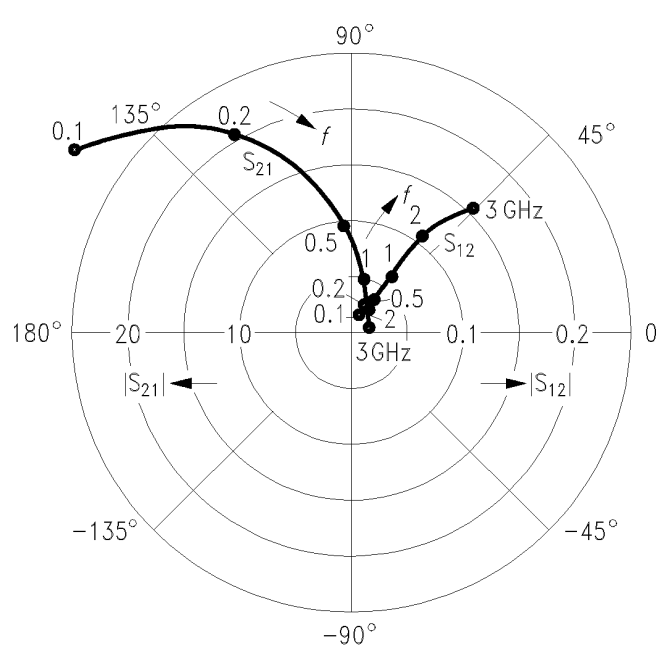

EHT07626



LittleDiode supplies new, hard to find or obsolete electronic components and semiconductors all over the world.

With over two million different components listed you are sure to find the part you need.

Feel free to visit us today at our online store:

LittleDiode.com

Looking forward to providing you with the best possible service.