

TOSHIBA BIPOLAR DIGITAL INTEGRATED CIRCUIT SILICON MONOLITHIC

# TD6358P, TD6358N

## FREQUENCY SYNTHESIZER FOR TV / CATV

The TD6358P and TD6358N are single-chip frequency synthesizer ICs, which can organization high-performance frequency synthesizer systems in combination with a 4bit  $\mu$ CPU controller.

The TD6358P integrates high input sensitivity ECL prescaler,  $I^2L$  programmable counter, PLL logic and bandswitch drive decoder in a DIP20-pin small package.

The TD6358N is packaged in a shrink 20-pin package even smaller than TD6358P.

### FEATURES

- High input sensitivity
  - $f_{in} = 80 \sim 100\text{MHz}$  :  $-24\text{dBmW}$  ( $50\Omega$ ) (Min.)
  - $f_{in} = 0.1 \sim 1\text{GHz}$  :  $-27\text{dBmW}$  ( $50\Omega$ ) (Min.)
- Wide operating frequency : 1GHz (Max.)
- Simple control bus : 19bit serial input
- 5V single power supply operation
- 3.2MHz basic oscillator and 50kHz frequency step
- Bandswitch driver : 4 channels

(Note) Handle with care as this product is weak at surge voltage.

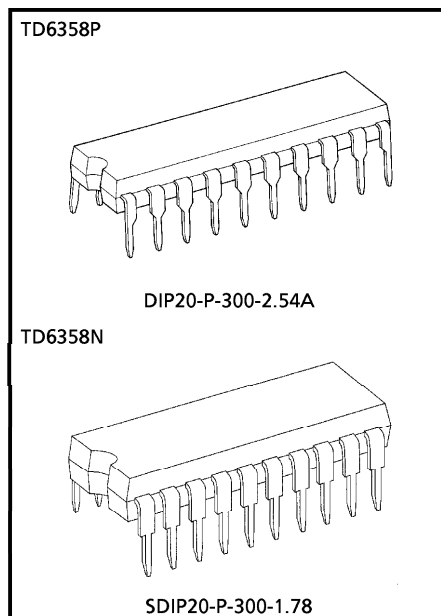

Weight  
 DIP20-P-300-2.54A : 2.25g (Typ.)  
 SDIP20-P-300-1.78 : 1.02g (Typ.)

980910EBA1

- TOSHIBA is continually working to improve the quality and the reliability of its products. Nevertheless, semiconductor devices in general can malfunction or fail due to their inherent electrical sensitivity and vulnerability to physical stress. It is the responsibility of the buyer, when utilizing TOSHIBA products, to observe standards of safety, and to avoid situations in which a malfunction or failure of a TOSHIBA product could cause loss of human life, bodily injury or damage to property. In developing your designs, please ensure that TOSHIBA products are used within specified operating ranges as set forth in the most recent products specifications. Also, please keep in mind the precautions and conditions set forth in the TOSHIBA Semiconductor Reliability Handbook.
- The products described in this document are subject to the foreign exchange and foreign trade laws.
- The information contained herein is presented only as a guide for the applications of our products. No responsibility is assumed by TOSHIBA CORPORATION for any infringements of intellectual property or other rights of the third parties which may result from its use. No license is granted by implication or otherwise under any intellectual property or other rights of TOSHIBA CORPORATION or others.
- The information contained herein is subject to change without notice.

BLOCK DIAGRAM

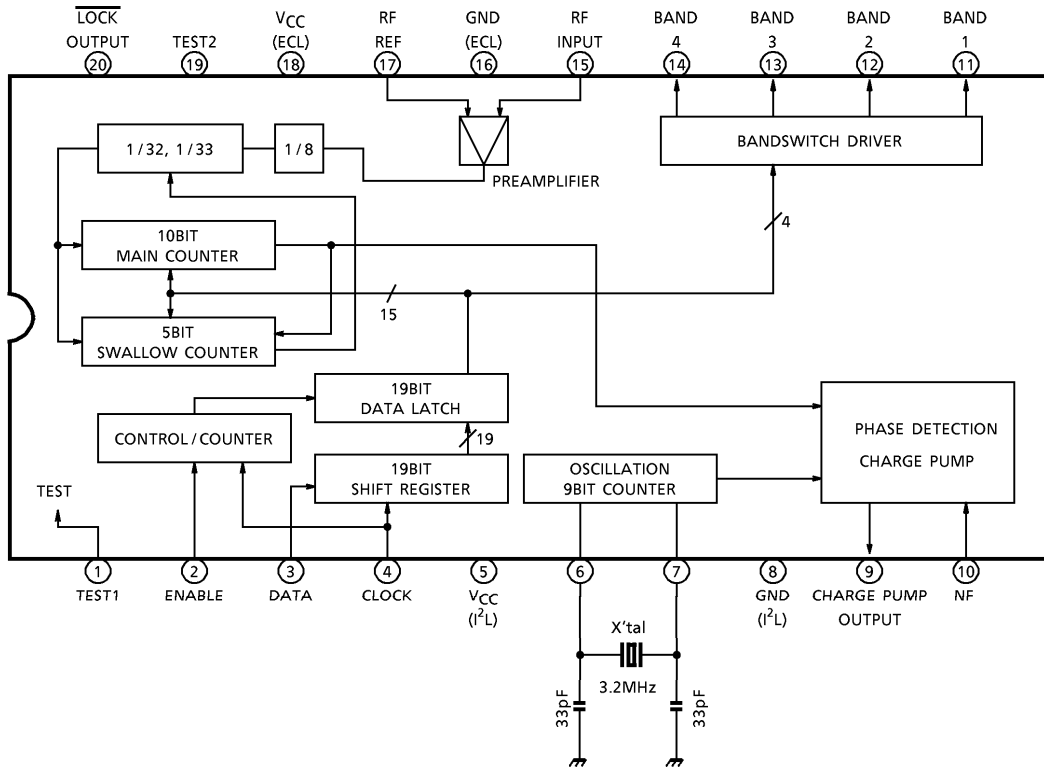

TERMINAL FUNCTION

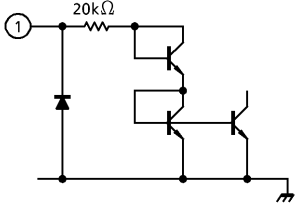
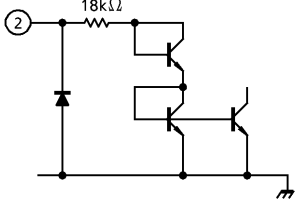
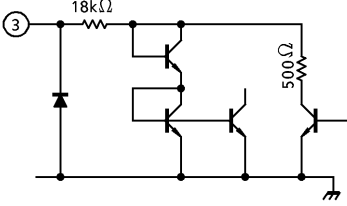
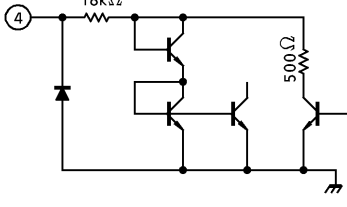
PIN No.	PIN NAME	FUNCTION	INTERFACE CIRCUIT
1	Test Pin 1	<p>Low level : this will be in normal use operation mode when connected to GND or open.</p> <p>In order to prevent a static breakdown, it will be more effective to connect to GND.</p> <p>High level : this will be in test mode when connected to <math>V_{CC}</math>.</p>	
2	Enable Input	<p>This is an enable pulse input terminal at normal use operation.</p> <p>This will be a test mode select terminal of test mode by means of the pin 1 mode select pin.</p> <p>In order to prevent a static breakdown, it will be effective to connect in series a resistor of about <math>1k\Omega</math>.</p> <p>The pins 3 and 4 below are the same as this pin.</p>	
3	Data Input	<p>This is a data input terminal in normal mode.</p> <p>In test mode 1 or 2, this will be a main counter output terminal.</p> <p>In test mode 3, this can be an external input terminal of comparison signal of phase comparator (a counter output terminal in normal mode).</p>	
4	Clock Input	<p>This is a clock pulse input terminal in normal mode.</p> <p>In test mode 1 or 2, this will be an output terminal of reference signal whose crystal oscillator is divided by <math>2^9</math>.</p> <p>In test mode 3, this can be an input terminal of external reference signal.</p>	
5	Logic $V_{CC}$	<p>This is logic circuit power supply.</p> <p>Connect a bypass condenser between this pin and pin 8.</p>	<p style="text-align: center;">—</p>

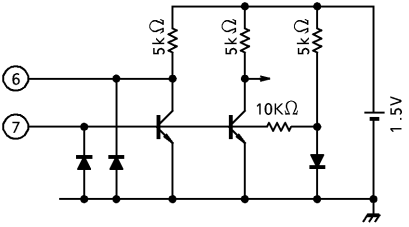
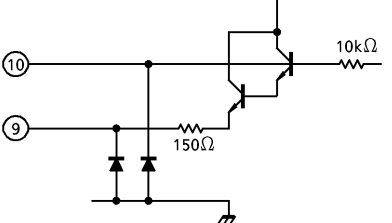
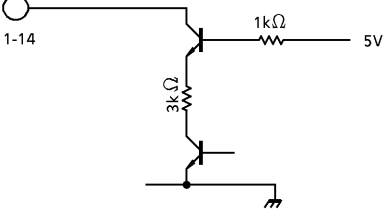
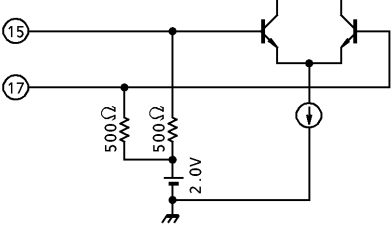
PIN No.	PIN NAME	FUNCTION	INTERFACE CIRCUIT
6 7	Crystal Oscillation	This is a crystal oscillation terminal to make the reference signal. Make sure to use the logic GND of pin 8 as this oscillates in a big amplitude (about 800mV <sub>p-p</sub> ).	
8	Logic GND	This is used for crystal oscillator GND as is logic GND. Never wire this pin close to the high frequency GND of pin 16.	—
9 10	Frequency Phase Comparator Output	In normal use, this compares a high frequency wave input with frequency data and feeds back its difference by means of the supply pump.	
11 ~ 14	Bandswitch	This can make the 4 band switching operate independently. The external driver can freely be operated anywhere between 1~4 pins. Connect an unused pin to the bandswitch power supply.	
15 17	Reference Bias By RF Input	This is an input terminal of local oscillation of tuner. In order to prevent disturbance or unwanted resonance, use the pattern of short distance or lead wire for pin 15. Also, connect a bypass condenser to pin 16 for pin 17 as well.	
16	High Frequency GND	This is mainly used for a bypass condenser of pins 17 and 18 as is high frequency GND. Also the pattern should be lay out so as to be separated from the logic GND of pin 8.	—

PIN No.	PIN NAME	FUNCTION	INTERFACE CIRCUIT
18	High Frequency VCC	This is high frequency circuit power supply. Connect a bypass condenser between this pin and pin 8.	—
19	Test Pin 2	This is used only when in test mode 2. This terminal is possible to be input to the main counter without passing through a 1/8 prescaler. Leave this pin open in normal use.	
20	$\overline{\text{Lock}}$ Output	In normal use, a pull up resistor is connected to VCC. It will be low level only when PLL is locked. In test mode, this will be the test 1 or 2 select terminal and in mode 3, this will be a 256 divided output terminal of high frequency input. This is used for measuring the input sensitivity of a prescaler.	

**OPERATION WHEN IN TEST MODE**

If the test 1pin (pin 1) is set to high level, this will be test mode.

There are three kinds of test modes as follows :

**(1) Mode 1, Mode 2**

In mode 1 and 2, a test to inspect the PLL lock condition is executed. After inputting data to the main counter and swallow counter by means of the method indicated in the diagram 2, the test 1 terminal (pin 1) will be set to high level while the enable terminal (pin 2) is held to low level. In this condition, a comparing frequency signal is output to the clock terminal (pin 4) and main counter division signal to the data terminal (pin 3).

The method of inputting to a divider has two kinds : mode 1 and mode 2.

**Mode 1.** This is the method of inputting from the RF input terminal (pin 15) by setting the lock terminal (pin 20) to high level.  
The lock condition in normal use operation can be inspected using this method.

**Mode 2.** This is the method of directly inputting to a 1/32 and 1/33 divider from the test 2 terminal (pin 19) without passing through a 1/8 prescaler by setting the lock terminal (pin 20) to low level.  
The input level should be indicated in the diagram 3.

**(2) Mode 3**

In mode 3, a prescaler, phase comparator, and charge pump will be tested.

If both test 1 terminal (pin 1) and enable terminal (pin 2) are set to high level, these will be mode 3. The clock terminal (pin 4) is a comparison reference frequency signal input of phase comparator, the data terminal (pin 3) is a compared frequency signal input, and the lock terminal (pin 20) is a prescaler output (the fixed dividing ratio of 1/256).

The output polarity of phase comparator is as follows :

INPUT FREQUENCY	CHARGE PUMP OUTPUT PIN (PIN 9)
Input frequency > Programmed frequency	High level
Input frequency < Programmed frequency	Low level



DIAGRAM 1. Normal use

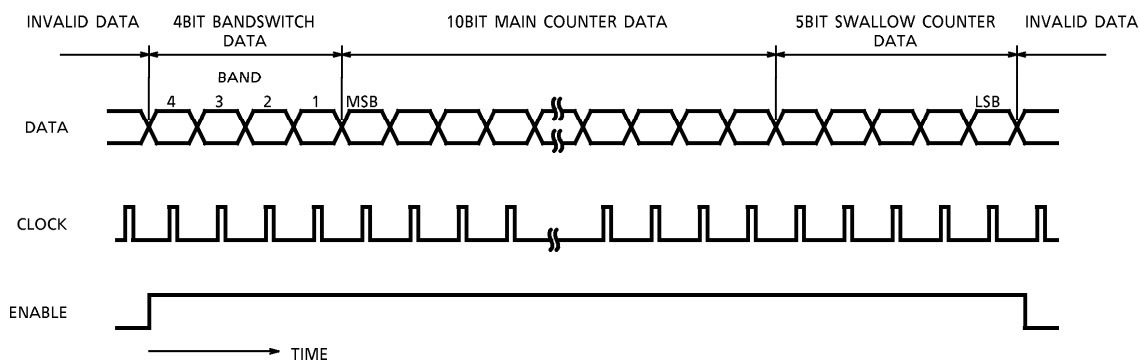

DIAGRAM 2. Test mode (Mode 1, 2)

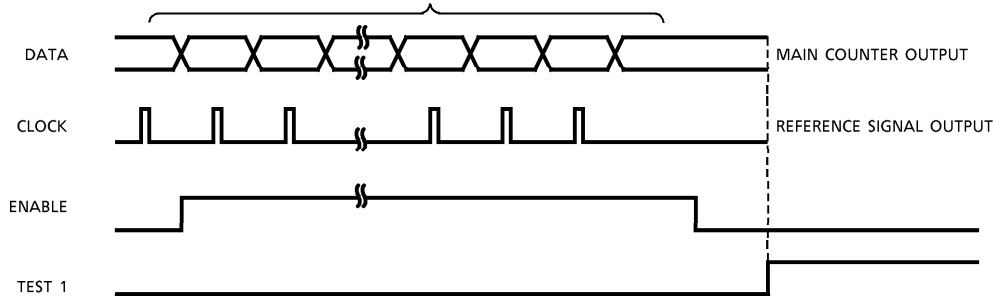
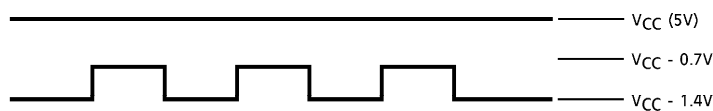

DIAGRAM 3. 1/32, 1/33 input level



MAXIMUM RATINGS (Ta = 25°C)

CHARACTERISTIC	SYMBOL	RATING	UNIT
Supply Voltage	V <sub>CC</sub>	6.5	V
ECL Input Voltage	V <sub>in1</sub>	2.0	V <sub>p-p</sub>
Logic Input Voltage	V <sub>in2</sub>	-0.3~V <sub>CC</sub>	V
Power Dissipation	P <sub>D</sub>	(Note 1)	W
Operating Temperature	T <sub>opr</sub>	-20~75	°C
Storage Temperature	T <sub>stg</sub>	-55~150	°C

(Note 1) P-type : 1.4W, N-type : 1.7W

(Note 2) When using the device at above Ta = 25°C, decrease the power dissipation by 11.2mW for P-type and 9.5mW for N-type for each increase of 1°C.

(Note 3) Handle with care as this product is weak at surge voltage.

RECOMMENDED SUPPLY VOLTAGE

PIN No.	PIN NAME	MIN.	TYP.	MAX.	UNIT
5	ECL $V_{CC}$	4.5	5	5.5	V
18	I <sup>2</sup> L $V_{CC}$	4.5	5	5.5	V

ELECTRICAL CHARACTERISTICS ( $V_{CC} = 5V, T_a = 25^{\circ}C$ )

CHARACTERISTIC		SYMBOL	TEST CIRCUIT	TEST CONDITION	MIN.	TYP.	MAX.	UNIT
Supply Current	(ECL)	$I_{CC1}$	2		40	60	80	mA
	(I <sup>2</sup> L)	$I_{CC2}$	2		15	25	35	
Bandswitch Max. Voltage		$V_B$ MAX.	—	Band 1~4	12	—	15	V
Bandswitch Inflow Current		$I_B$ MAX.	—	$V_{CC} = 5V$	0.7	—	2.2	mA
DC Voltage		$V_{15}$	—	—	1.7	2.0	2.3	V
		$V_{17}$	—	—	1.7	2.0	2.3	
DC Current High Level		$I_{IH}$	—	$V_{in} = 5V$ (Note 1)	—	180	300	$\mu A$
Input Voltage	"H" Level	$V_{IH}$	—	(Note 1)	3.0	—	—	V
	"L" Level	$V_{IL}$	—		—	—	0.8	
Output Voltage	"H" Level	$V_{OH}$	1	(Note 2)	3.8	—	—	V
	"L" Level	$V_{OL}$	1		—	—	0.5	
N/F Leak Current		$I_L$	—	(Note 3)	-0.2	—	0.2	$\mu A$
RF Input Sensitivity		$V_{in1}$	3	$f_{in} = 80-100MHz$	-24	—	3	dBmW (50 $\Omega$ )
		$V_{in2}$	3	$f_{in} = 100-1000MHz$	-27	—	3	
Setup Time		$T_s$	—	Data timing chart	2	—	—	$\mu s$
Enable Hold Time		$T_{sL}$	—		2	—	—	
Enable Inhibit Time		$T_{NE}$	—		6	—	—	
Clock Inhibit Time		$T_{NC}$	—		6	—	—	
Clock Width		$T_c$	—		2	—	—	
Enable Setup Time		$T_L$	—		10	—	—	
Data Hold Time		$T_H$	—		2	—	—	

(Note 1) TEST 1, Enable, Clock,  $\overline{Lock}$  : applied to input mode.

(Note 2) Data, Clock,  $\overline{Lock}$  : applied to output mode.

(Note 3) Pin 10 : 2.1V, Pin 9 : Open

TEST CIRCUIT 1. Test mode

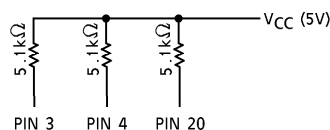

TEST CIRCUIT 2. Supply test circuit

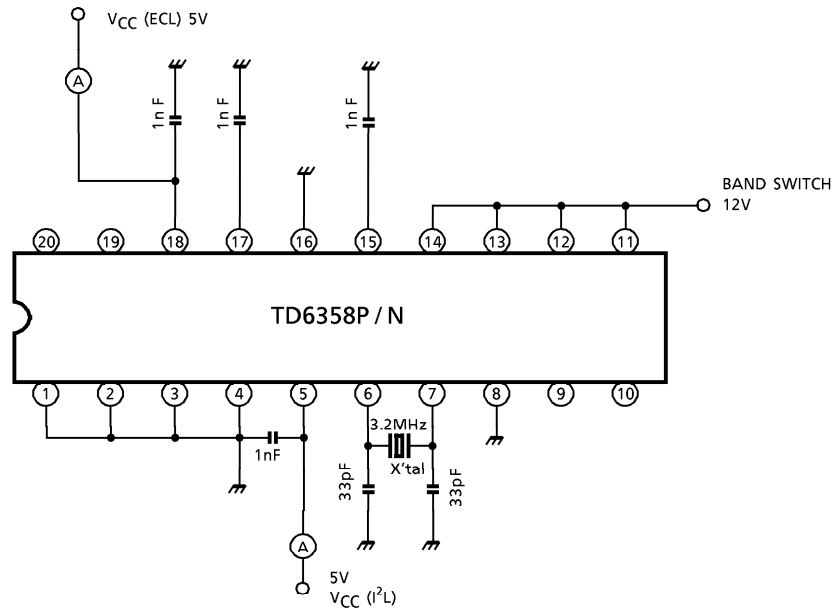

Bandswitch output circuit

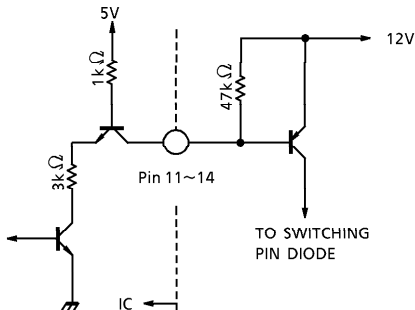

Phase detection output circuit

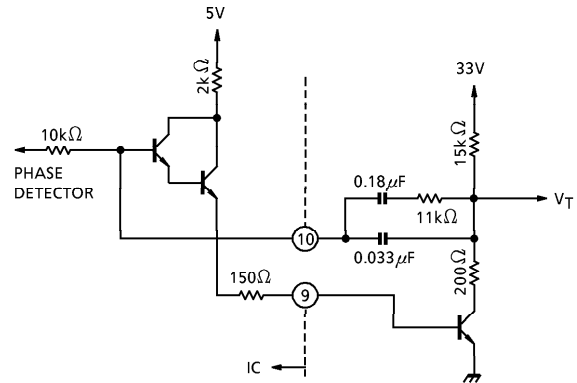

The output polarity of phase detector is as follows :

INPUT FREQUENCY	P.D. OUTPUT (PIN 9)
Input frequency > Programmed frequency	High level
Input frequency < Programmed frequency	Low level

TEST CIRCUIT 3. Input sensitivity test circuit

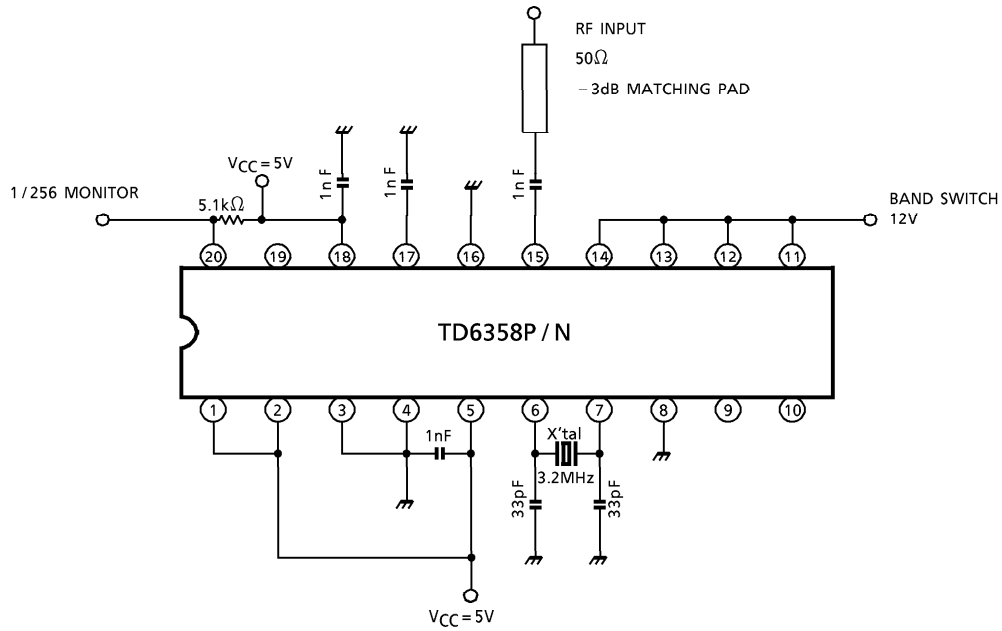

DATA TIMING CHART (Rising timing)

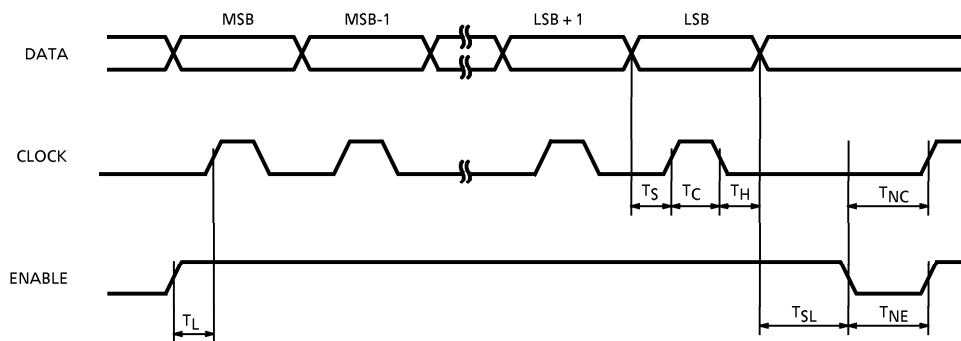

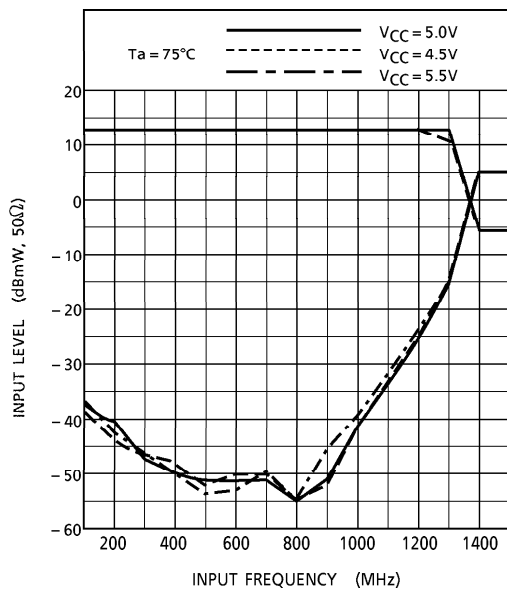
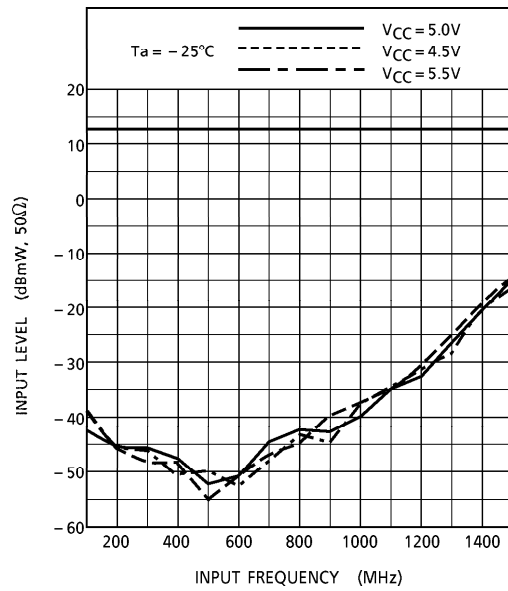
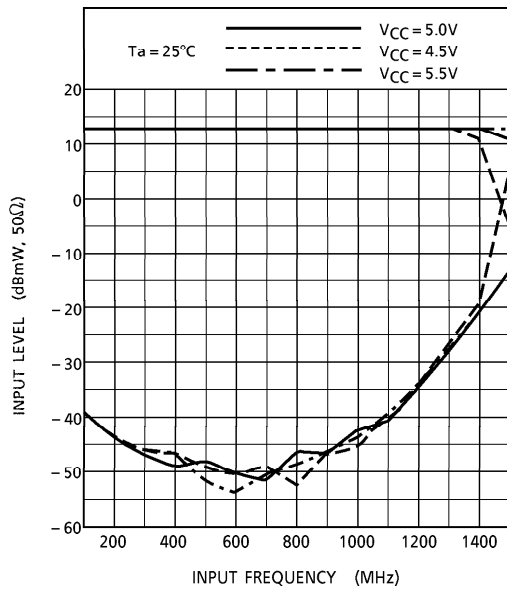

APPLICATION CIRCUIT EXAMPLE OF FREQUENCY SYNTHESIZER

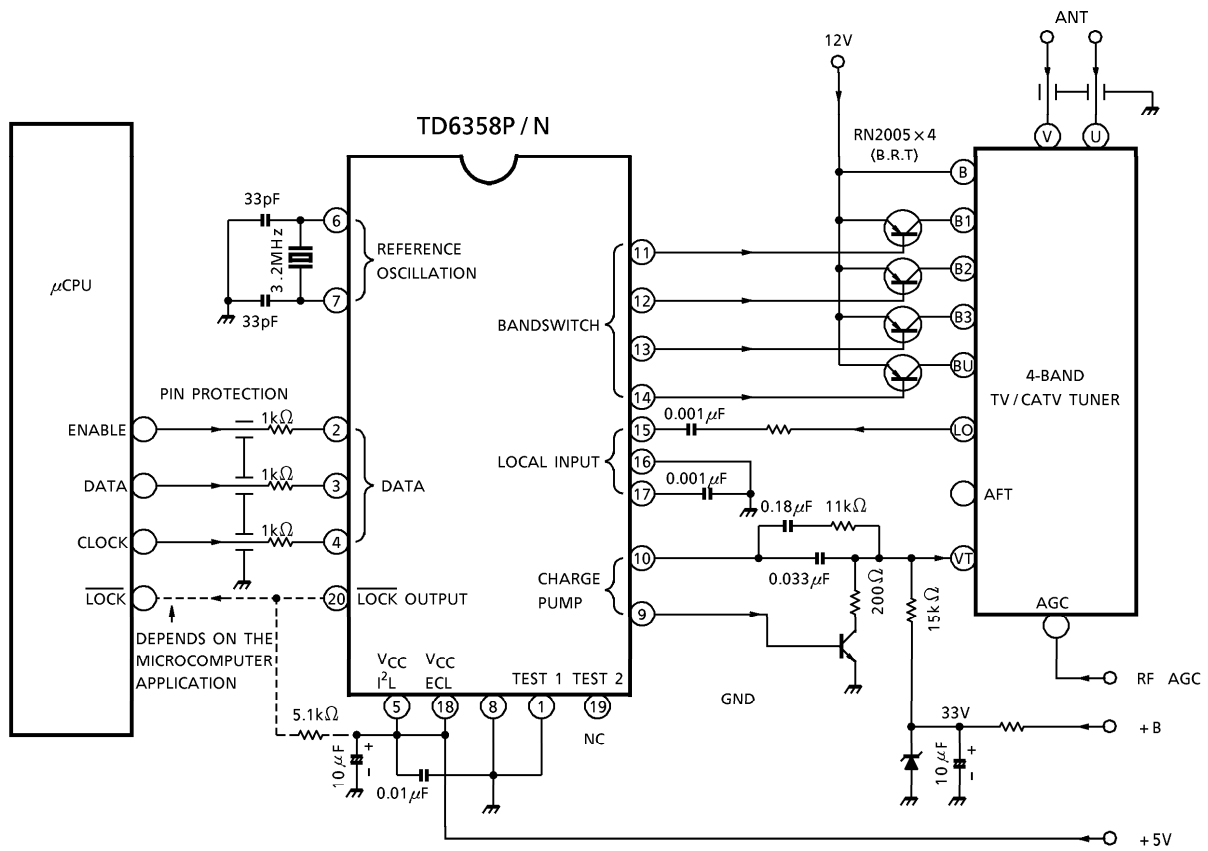

OUTLINE DRAWING  
DIP20-P-300-2.54A

Unit : mm

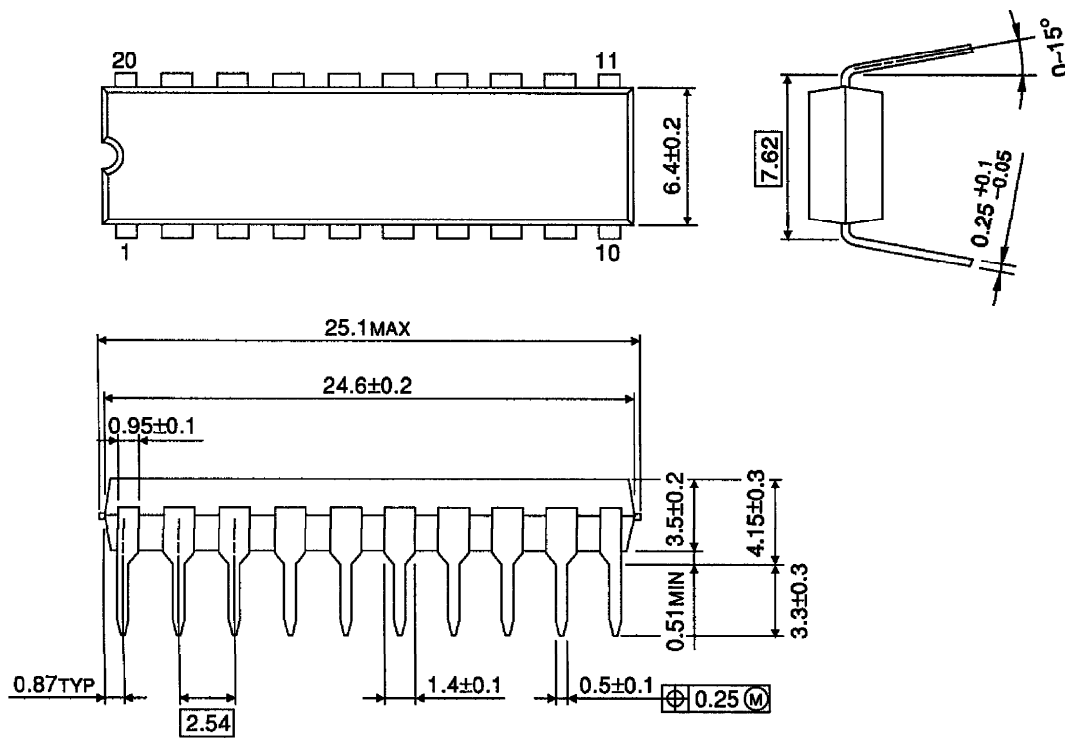

Weight : 2.25g (Typ.)

OUTLINE DRAWING  
SDIP20-P-300-1.78

Unit : mm

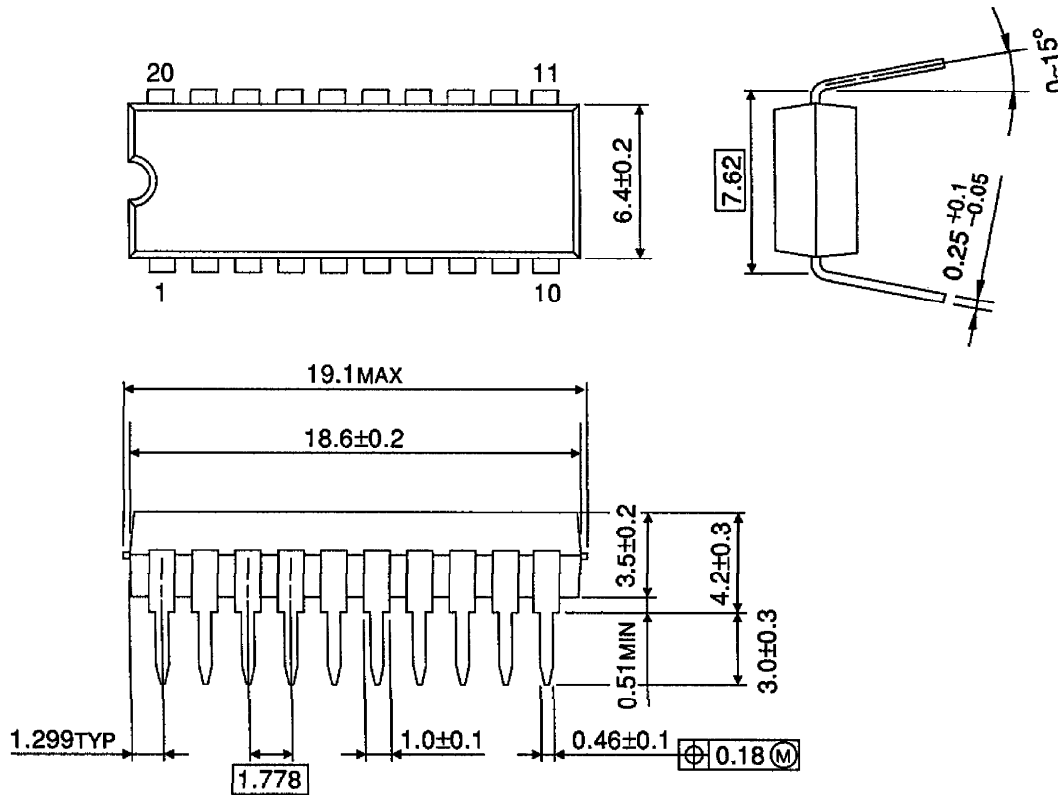

Weight : 1.02g (Typ.)