

2 x 22 W stereo BTL car radio power amplifier with loudspeaker protection and 3-state mode switch

TDA1553CQ

FEATURES

- Few peripheral components
- High output power
- Low output offset voltage
- Fixed gain
- Loudspeaker protection
- Good ripple rejection
- 3-state mode switch (operating, mute, stand-by)
- Load dump protection
- AC and DC short-circuit safe to ground and to V_p
- Thermally protected
- Reverse polarity safe
- High energy handling capability at the outputs ($V_p = 0$)
- Electrostatic discharge protection
- No switch-on/switch-off pop
- Flexible leads
- Low thermal resistance

GENERAL DESCRIPTION

The TDA1553CQ is a monolithic integrated class-B output amplifier in a 13-lead single-in-line (SIL) power package. It contains 2 x 22 W amplifiers in BTL configuration.

The device is primarily developed for car radio applications.

QUICK REFERENCE DATA

SYMBOL	PARAMETER	CONDITIONS	MIN.	TYP.	MAX.	UNIT
V_p	positive supply voltage					
	operating		6	14.4	18	V
	non-operating		–	–	30	V
	load dump		–	–	45	V
I_{ORM}	repetitive peak output current		–	–	4	A
I_p	total quiescent current		–	80	–	mA
I_{sb}	stand-by current		–	40	100	μ A
$ Z_i $	input impedance		50	–	–	k Ω
T_{vj}	virtual junction temperature		–	–	150	$^{\circ}$ C
Stereo application						
P_o	output power	at 4 Ω ; THD = 10%	–	22	–	W
RR	supply voltage ripple rejection	$R_s = 0 \Omega$; $f = 100 \text{ Hz to } 10 \text{ kHz}$	48	–	–	dB
$ \Delta V_o $	DC output offset voltage		–	–	150	mV
α	channel separation		40	–	–	dB
$ \Delta G_v $	channel unbalance		–	–	1	dB

ORDERING INFORMATION

EXTENDED TYPE NUMBER	PACKAGE			
	PINS	PIN POSITION	MATERIAL	CODE
TDA1553CQ	13	SIL	plastic	SOT141R

2 x 22 W stereo BTL car radio power amplifier with loudspeaker protection and 3-state mode switch

TDA1553CQ

PINNING

SYMBOL	PIN	DESCRIPTION
IN 1	1	input 1
GND(S)	2	signal ground
V _{P1}	3	supply voltage
OUT 1A	4	output 1A
GND1	5	power ground 1
OUT 1B	6	output 1B
OUT 2A	7	output 2A
GND2	8	power ground 2
OUT 2B	9	output 2B
V _{P2}	10	supply voltage
MODE	11	mode switch input
LSP	12	loudspeaker protection
IN 2	13	input 2

FUNCTIONAL DESCRIPTION

The TDA1553CQ contains two identical amplifiers with differential input stages and can be used for bridge applications. The gain of each amplifier is fixed at 26 dB. Special features of the device are:

3-state mode switch

- standby : low supply current (< 100 μ A)
- mute : input signal suppressed
- operating: normal on condition

Loudspeaker protection

When a short-circuit to ground occurs, which forces a DC voltage across the loudspeaker of ≥ 1 V, a built-in protection circuit becomes active and limits the DC voltage across the loudspeaker to ≤ 1 V. Pin 12 detects the status of the protection circuit, (e.g. for diagnostic purposes).

Short-circuit protection

If any output is short-circuited to ground during the stand-by mode, it becomes impossible to switch the circuit to the mute or operating condition. In this event the supply current will be limited to a few milliamps.

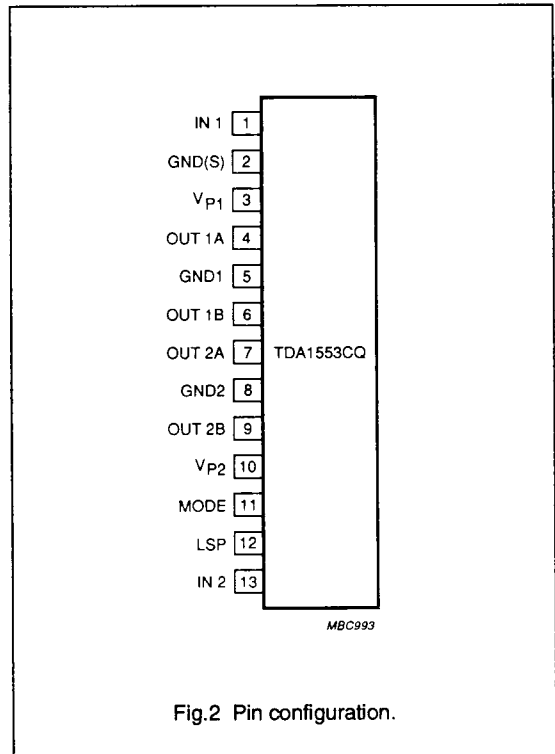

2 x 22 W stereo BTL car radio power amplifier with loudspeaker protection and 3-state mode switch

TDA1553CQ

LIMITING VALUES

In accordance with the absolute maximum system (IEC 134)

SYMBOL	PARAMETER	CONDITION	MIN.	MAX.	UNIT
V_p	positive supply voltage				
	operating		-	18	V
	non-operating		-	30	V
	load dump protection	during 50 ms; $t_r \geq 2.5$ ms	-	45	V
I_{OSM}	non-repetitive peak output current		-	6	A
I_{ORM}	repetitive peak output current		-	4	A
T_{stg}	storage temperature range		-55	150	°C
T_{amb}	operating ambient temperature range		-40	85	°C
T_{vj}	virtual junction temperature		-	150	°C
V_{psc}	AC and DC short-circuit safe voltage		-	18	V
	energy handling capability at outputs	$V_p = 0$	-	200	mJ
V_{pr}	reverse polarity		-	6	V
P_{tot}	total power dissipation		-	60	W

THERMAL RESISTANCE

In accordance with IEC 747-1

SYMBOL	PARAMETER	CONDITIONS	THERMAL RESISTANCE
$R_{th\ j-e}$	from junction to ambient in free air		40 K/W
$R_{th\ j-c}$	from junction to case	see Fig.3	1.5 K/W

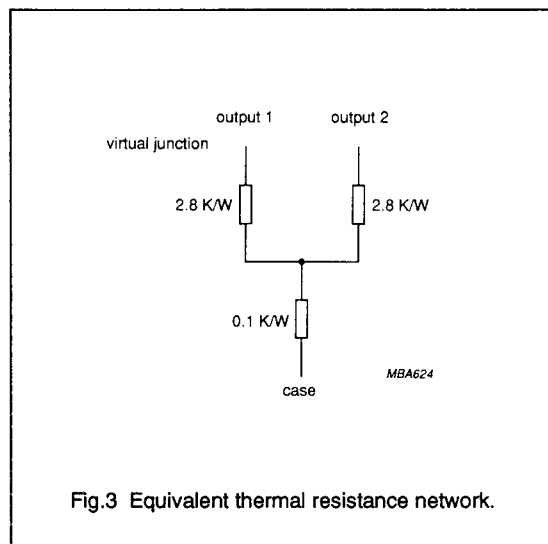

2 x 22 W stereo BTL car radio power amplifier with loudspeaker protection and 3-state mode switch

TDA1553CQ

DC CHARACTERISTICS
 $V_p = 14.4 \text{ V}$; $T_{amb} = 25 \text{ }^\circ\text{C}$; measured in Fig.4; unless otherwise specified

SYMBOL	PARAMETER	CONDITIONS	MIN.	TYP.	MAX.	UNIT
Supply						
V_p	positive supply voltage	note 1	6	14.4	18	V
I_p	quiescent current	$R_L = \infty$	–	80	160	mA
		note 2	–	5.5	–	mA
Operating condition						
V_{11}	mode switch voltage level		2.2	–	7	V
I_{11}	mode switch current	$V_{11} = 2.2 \text{ V}$	–	50	100	μA
V_o	DC output voltage	note 3	–	6.9	–	V
$ \Delta V_o $	DC output offset voltage		–	–	150	mV
Mute condition						
V_{11}	mode switch voltage level		0	–	0.6	V
$-I_{11}$	mode switch current	$V_{11} = 0.6 \text{ V}$	–	50	100	μA
V_o	DC output voltage	note 3	–	6.9	–	V
$ \Delta V_o $	DC output offset voltage		–	–	150	mV
Stand-by condition						
$ I_{11} $	mode switch 3-state leakage current		–	–	10	μA
I_{sb}	stand-by current	$I_{11} = 0 \text{ } \mu\text{A}$	–	40	100	μA
Loudspeaker protection						
$ \Delta V_{4,6} $ or $ \Delta V_{7,9} $	DC voltage across R_L		–	–	1	V
Protection active ($\Delta V_{4,6}$ or $\Delta V_{7,9} \geq 1.0 \text{ V}$)						
I_{12}	current information		–	25	–	μA
V_{12}	voltage information		3.6	–	–	V
Protection not active ($\Delta V_{4,6}$ and $\Delta V_{7,9} \leq 0.15 \text{ V}$)						
V_{12}	voltage information		–	–	0.3	V

2 x 22 W stereo BTL car radio power amplifier with loudspeaker protection and 3-state mode switch

TDA1553CQ

AC CHARACTERISTICS

$V_p = 14.4$ V; $R_L = 4$ Ω ; $f = 1$ kHz; $T_{amb} = 25$ °C; measured in Fig.4; unless otherwise specified

SYMBOL	PARAMETER	CONDITIONS	MIN.	TYP.	MAX.	UNIT
P_o	output power	$V_p = 14.4$ V				
		THD = 0.5%	15	17	–	W
		THD = 10%	20	22	–	W
THD	total harmonic distortion	$P_o = 1$ W	–	0.1	–	%
P_o	output power	$V_p = 13.2$ V				
		THD = 0.5%	–	12	–	W
		THD = 10%	–	17	–	W
B	power bandwidth	THD = 0.5%; $P_o = -1$ dB; with respect to 15 W	–	20 - 15000	–	Hz
f_l	low frequency roll-off	at -1 dB; note 4	–	25	–	Hz
f_h	high frequency roll-off	at -1 dB	20	–	–	kHz
G_v	closed loop voltage gain		25	26	27	dB
RR	supply voltage ripple rejection on mute stand-by	note 5				
			48	–	–	dB
			48	–	–	dB
		80	–	–	dB	
$ Z_i $	input impedance		50	60	75	k Ω
V_{no}	noise output voltage on on	note 6				
		$R_S = 0$ Ω	–	70	120	μ V
		$R_S = 10$ k Ω	–	100	–	μ V
V_{no}	noise output voltage mute	notes 6 and 7	–	60	–	μ V
α	channel separation	$R_S = 10$ k Ω	40	–	–	dB
$ \Delta G_v $	channel unbalance		–	–	1	dB
V_o	output voltage in mute	note 8	–	–	2	mV

Notes to the characteristics

- The circuit is DC adjusted at $V_p = 6$ to 18 V and AC operating at $V_p = 9$ to 18 V.
- If any output is short-circuited to ground during the stand-by mode and in this condition the circuit is switched to mute or operating.
- At 18 V < V_p < 30 V the DC output voltage $\leq V_p/2$.
- Frequency response externally fixed.
- Ripple rejection measured at the output with a source-impedance of 0 Ω , maximum ripple amplitude of 2 V p-p and at a frequency between 100 Hz and 10 kHz.
- Noise measured in a bandwidth of 20 Hz to 20 kHz.
- Noise output voltage independent of R_S ($V_i = 0$ V).
- $V_i = V_{imax} = 1$ V RMS.

2 x 22 W stereo BTL car radio power amplifier with
loudspeaker protection and 3-state mode switch

TDA1553CQ

TEST/APPLICATION INFORMATION

