

## Request For Quotation

Order the parts you need from our real-time inventory database. Simply complete a request for quotation form with your part information and a sales representative will respond to you with price and availability.

[Request For Quotation](#)

**Your free datasheet starts on the next page.**

More datasheets and data books are available from our homepage: <http://www.datasheetarchive.com>

# DATA SHEET

**TDA1576T**

**FM/IF amplifier/demodulator circuit**

Product specification  
Supersedes data of February 1991  
File under Integrated Circuits, IC01

1998 Nov 18

**FM/IF amplifier/demodulator circuit****TDA1576T****FEATURES**

- Fully balanced 4-stage limiting IF amplifier
- Symmetrical quadrature demodulator
- Field strength indication output for 1 mA ammeter
- Detune detector for side response and noise attenuation
- Detune voltage output
- Internal muting circuit
- 0° and 180° AF output signals
- Reference voltage output
- Electronic smoothing of the supply voltage.

**GENERAL DESCRIPTION**

The TDA1576T is a monolithic integrated FM/IF amplifier circuit for use in mono and stereo FM-receivers of car radios or home sets.

**QUICK REFERENCE DATA**

SYMBOL	PARAMETER	CONDITIONS	MIN.	TYP.	MAX.	UNIT
$V_P$	supply voltage (pin 1)		7.5	8.5	15	V
$I_P$	supply current		10	16	23	mA
$V_{iIF(rms)}$	input sensitivity (RMS value)	-3 dB before limiting	14	22	35	$\mu$ V
		S/N = 26 dB	-	10	-	$\mu$ V
		S/N = 46 dB	-	55	-	$\mu$ V
$V_{oAF(rms)}$	AF output voltage (RMS value)		60	67	75	mV
THD	total harmonic distortion with double resonant circuits		-	0.02	-	%
S/N	signal-to-noise ratio	$V_i > 1$ mV	-	72	-	dB
$\alpha_{AM}$	AM suppression		-	50	-	dB
RR	ripple rejection	f = 100 Hz	43	48	-	dB
$I_{15}$	maximum indicator output current		-	-	2	mA
$T_{amb}$	operating ambient temperature		-30	-	+80	°C

**ORDERING INFORMATION**

TYPE NUMBER	PACKAGE		
	NAME	DESCRIPTION	VERSION
TDA1576T	SO20	plastic small outline package; 20 leads; body width 7.5 mm	SOT163-1

FM/IF amplifier/demodulator circuit

TDA1576T

BLOCK DIAGRAM

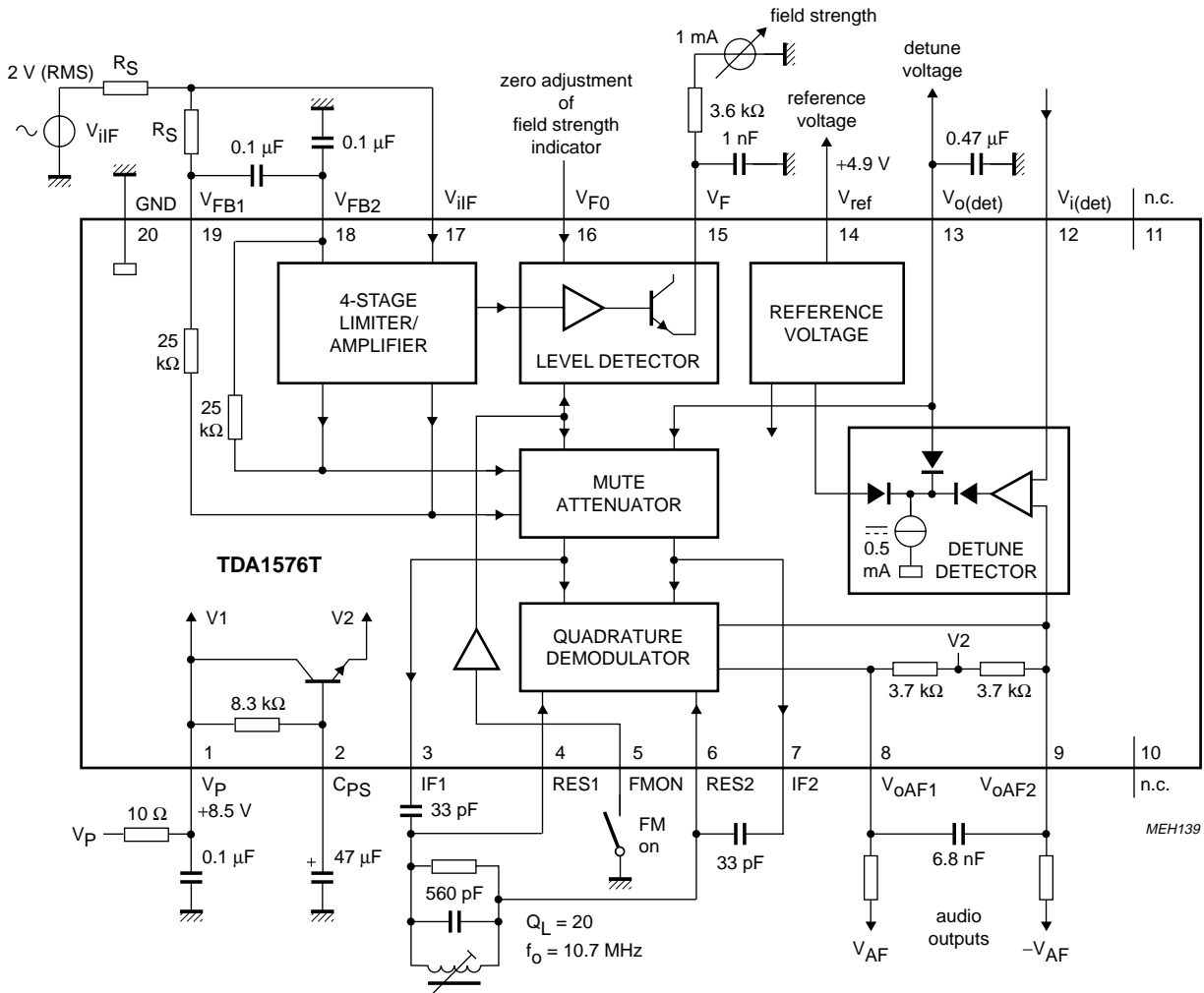

Fig.1 Block diagram.

FM/IF amplifier/demodulator circuit

TDA1576T

PINNING

SYMBOL	PIN	DESCRIPTION
$V_P$	1	positive supply voltage
$C_{PS}$	2	smoothing capacitor of power supply
IF1	3	IF signal to resonant circuit
RES1	4	resonant circuit input 1
FMON	5	FM-ON, standby switch
RES2	6	resonant circuit input 2
IF2	7	IF signal to resonant circuit
$V_{oAF1}$	8	AF output voltage 1 ( $0^\circ$ phase)
$V_{oAF2}$	9	AF output voltage 2 ( $180^\circ$ phase)
n.c.	10	not connected
n.c.	11	not connected
$V_{i(det)}$	12	detune detector input voltage for external audio reference
$V_{o(det)}$	13	detune detector output voltage
$V_{ref}$	14	reference voltage output
$V_F$	15	level output for field strength
$V_{F0}$	16	zero adjust voltage for field strength
$V_{iIF}$	17	FM/IF input signal voltage
$V_{FB2}$	18	DC feedback 2
$V_{FB1}$	19	DC feedback 1
GND	20	ground (0 V)

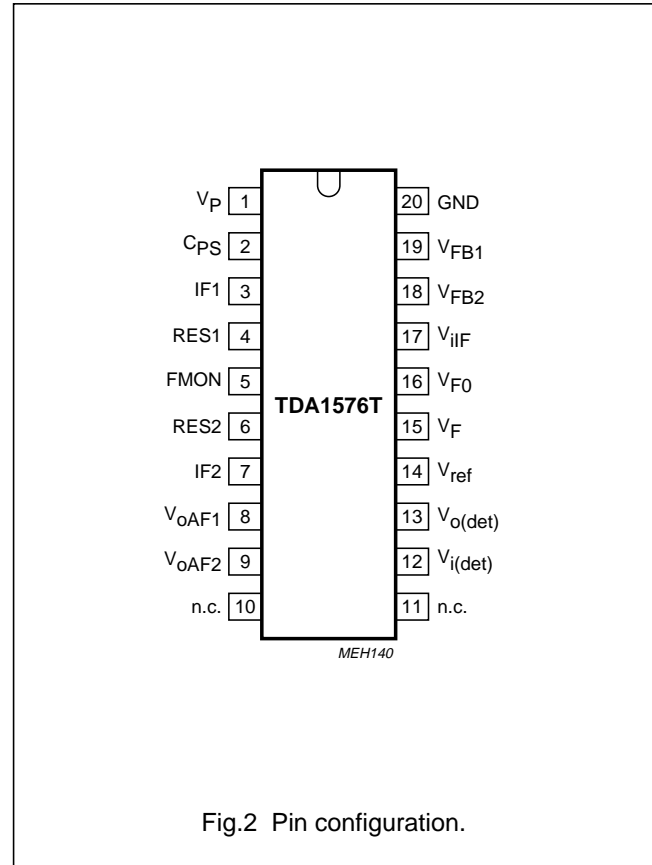

Fig.2 Pin configuration.

## FM/IF amplifier/demodulator circuit

TDA1576T

**LIMITING VALUES**

In accordance with the Absolute Maximum Rating System (IEC 134).

SYMBOL	PARAMETER	MIN.	MAX.	UNIT
$V_P$	supply voltage (pin 1)	0	15	V
$V_{2, 5, 16}$	voltage on pins 2, 5 and 16	0	$V_P$	V
$P_{tot}$	total power dissipation	0	450	mW
$T_{stg}$	storage temperature	-55	+150	°C
$T_{amb}$	operating ambient temperature	-30	+80	°C

**THERMAL CHARACTERISTICS**

SYMBOL	PARAMETER	VALUE	UNIT
$R_{th\ j-a}$	thermal resistance from junction to ambient in free air	85	K/W

## FM/IF amplifier/demodulator circuit

## TDA1576T

**CHARACTERISTICS**

$V_P = 8.5$  V;  $f_{IF} = 10.7$  MHz;  $R_S = 60$   $\Omega$ ;  $f_m = 400$  Hz with  $\Delta f = \pm 22.5$  kHz; 50  $\mu$ s de-emphasis ( $C_{8,9} = 6.8$  nF);

$T_{amb} = 25$  °C and measurements taken in Fig.1; unless otherwise specified. The demodulator circuit is adjusted at minimum second harmonic distortion for  $V_{iIF} = 1$  mV and a deviation  $\Delta f = \pm 75$  kHz.

SYMBOL	PARAMETER	CONDITIONS	MIN.	TYP.	MAX.	UNIT
$V_P$	supply voltage (pin 1)		7.5	8.5	15	V
$I_P$	supply current	$V_5 = V_9 = V_{13} = 0$	10	16	23	mA
<b>Reference voltage</b>						
$V_{ref}$	reference voltage (pin 14)	$I_{14} = -1$ mA	–	4.9	–	V
$\Delta V_{ref}$	reference voltage dependence on temperature	$\frac{\Delta V_{14}}{V_{14} \times \Delta T}$	–	0.3	–	%/K
$I_{14}$	maximum output current	short-circuit current	4	6	7.5	mA
$R_{14}$	output resistor $\frac{\Delta V_{14}}{\Delta I_{14}}$	$I_{14} < 1.2$ mA	–	60	150	$\Omega$
<b>IF amplifier</b>						
$V_{iIF(rms)}$	input sensitivity (RMS value; pin 17)	–3 dB before limiting	14	22	35	$\mu$ V
$R_{17-18}$	input resistance	$V_{iIF} = 200$ mV (RMS)	10	–	–	k $\Omega$
$C_{17-18}$	input capacitance	$V_{iIF} = 200$ mV (RMS)	–	5	–	pF
$V_{oIF(p-p)}$	output voltage at pins 3 and 7 (peak-to-peak value)	$Z_{3,7} = 10$ pF parallel to 1 M $\Omega$	610	680	750	mV
$R_{3-7}$	output resistance		200	250	300	$\Omega$
<b>Demodulator</b>						
$R_{4-6}$	input resistance		20	30	40	k $\Omega$
$C_{4-6}$	input capacitance		–	1	2.5	pF
$R_{8,9}$	output resistance		2.9	3.7	4.5	k $\Omega$
$V_{8,9}$	DC offset voltage on output pins at $V_{4-6} = 0$	$V_5 > 3$ V or $V_{3-7} = 0$ or $V_{13} < 0.3$ V	–	0	$\pm 100$	mV
$\frac{\Delta V}{\Delta \phi}$	demodulator efficiency	$\frac{\Delta V_{8-9}}{\Delta \phi}$	–	40	–	mV/°
	demodulator efficiency dependent on supply voltage	$\frac{V_{8-9}}{\Delta \phi (V_P - 3V_{BE})}$	–	6.2	–	mV/°
V/V	DC voltage ratio	$\frac{V_8 + V_9}{2V_2}$	0.653	0.667	0.680	V/V
$\frac{\Delta V}{\Delta T}$	dependence on temperature	$\frac{\Delta (V_8 + V_9)}{2V_2 \Delta T}$	–	$10^{-5}$	–	1/K

## FM/IF amplifier/demodulator circuit

## TDA1576T

SYMBOL	PARAMETER	CONDITIONS	MIN.	TYP.	MAX.	UNIT
<b>Field strength output; see Fig.4</b>						
V <sub>15</sub>	output voltage	V <sub>ilF</sub> = 0	0	0.1	0.25	V
		V <sub>ilF</sub> = 1 mV (RMS)	1.1	1.5	1.9	V
		V <sub>ilF</sub> = 250 mV (RMS)	3.2	3.6	4.1	V
S	control steepness		–	0.85	–	V/dec
R <sub>15</sub>	output resistance		–	150	200	Ω
$\frac{\Delta V}{\Delta T}$	dependence on temperature	$V_{ilF} = \frac{\Delta V_{15}}{\Delta T \times V_{15}}$	–	0.3	–	%/K
I <sub>15</sub>	standby operational cut-off current	V <sub>5</sub> ≥ 3 V; V <sub>15</sub> = 0 to 5 V	–	–	10	μA
<b>Zero level adjustment</b>						
V <sub>16</sub>	internal bias voltage		–	260	–	mV
R <sub>16</sub>	input resistance		–	19	–	kΩ
S	control steepness	V <sub>ilF</sub> = 100 mV; $A = \frac{\Delta V_{15}}{\Delta V_{16}}$	0.87	1.0	1.2	V/V
<b>Detuning detector</b>						
I <sub>12</sub>	input bias current		–	20	100	nA
Z <sub>12</sub>	input impedance	$Z_{12} = \frac{5 V}{\Delta I_{12}}$ ; see Fig.5	6	30	–	MΩ
$\frac{V_{13}}{V_{14}}$	output voltage ratio for $\Delta\phi = \phi(V_{3-7}) - \phi(V_{4-6}) - 90^\circ$  $\Delta\phi = 9.2^\circ$ (43 kHz); Q = 20 $\Delta\phi = 3.5^\circ$ (16 kHz); Q = 20 $\Delta\phi = 14^\circ$ (65 kHz); Q = 20	V <sub>1</sub> = V <sub>2</sub> = 7.5 V; R <sub>13-14</sub> = 10 kΩ; pins 9 and 12 short-circuit; see Fig.6  V <sub>9, 12</sub> = 334 mV V <sub>9, 12</sub> = 138 mV V <sub>9, 12</sub> = 501 mV	0.45 0.75 0.335	0.5 0.8 0.345	0.55 0.85 0.355	V/V V/V V/V
I <sub>13</sub>	maximum output current	V <sub>13</sub> = 6 V; see Fig.7	0.4	0.5	0.6	mA
	cut-off current	V <sub>13</sub> = 2.5 V; V <sub>9, 12</sub> = 0	–	–	–100	nA
<b>Internal audio attenuation; see Fig.8</b>						
$\frac{V_{13}}{V_{14}}$	output voltage ratio	α = attenuation factor α = 1 dB α = 7.2 dB α ≥ 40 dB	0.11 0.095 –	0.12 0.1 0.06	0.13 0.105 –	V/V V/V V/V
I <sub>13</sub>	input current	V <sub>13</sub> ≤ 0.1 V	–	–	–225	nA

## FM/IF amplifier/demodulator circuit

## TDA1576T

SYMBOL	PARAMETER	CONDITIONS	MIN.	TYP.	MAX.	UNIT
<b>Standby switch; see Fig.9</b>						
V <sub>5</sub>	input voltage for FM on	$\frac{V_{3,7}}{V_{3,7(\max)}} = 0.9;$ V <sub>19</sub> = 0.3 V	2.4	2.5	–	V
	input voltage for FM off		–	2.9	3	V
	linear range		–	350	–	mV
I <sub>5</sub>	input current	V <sub>5</sub> = 0 to 2 V	–	–	–100	μA
		V <sub>5</sub> = 3.5 to 15 V	–	–	1	μA
$\frac{V_5}{\Delta T}$	temperature dependence	FM on (3.5V <sub>BE</sub> )	–	7	–	mV/K
		FM off (5V <sub>BE</sub> )	–	10	–	mV/K
<b>Supply voltage smoothing</b>						
V <sub>1-2</sub>	internal voltage drop	proportional to V <sub>1</sub> – 3V <sub>BE</sub>	80	210	400	mV
R <sub>1-2</sub>	internal resistor		5.8	8.3	10.8	kΩ

**OPERATING CHARACTERISTICS**

V<sub>P</sub> = 8.5 V; f<sub>IF</sub> = 10.7 MHz; R<sub>S</sub> = 60 Ω; f<sub>m</sub> = 400 Hz with Δf = ±22.5 kHz; 50 μs de-emphasis (C<sub>8-9</sub> = 6.8 nF);

T<sub>amb</sub> = 25 °C and measurements taken in Fig.1; unless otherwise specified. The demodulator circuit is adjusted at minimum second harmonic distortion with V<sub>ilF</sub> = 1 mV.

SYMBOL	PARAMETER	CONDITIONS	MIN.	TYP.	MAX.	UNIT
<b>IF amplifier and demodulator</b>						
V <sub>ilF(rms)</sub>	input sensitivity (RMS value)	–3 dB before limiting	14	22	35	μV
		S/N = 26 dB	–	10	–	μV
		S/N = 46 dB	–	55	–	μV
V <sub>oAF(rms)</sub>	AF output voltage (RMS value)		60	67	75	mV
V <sub>oN</sub>	noise voltage for V <sub>ilF</sub> = 0 (RMS value; pins 8 and 9)	R <sub>S</sub> = 300 Ω; f = 250 to 15000 Hz	–	900	–	μV
	weighted noise voltage	in accordance with "DIN 45405"	–	2	–	mV
S/N	signal-to-noise ratio (pins 8 and 9)	V <sub>ilF</sub> = 1 mV (RMS); see Fig.3	–	72	–	dB
α <sub>AM</sub>	AM suppression	V <sub>ilF</sub> = 0.5 to 200 mV; FM: 70 Hz; ±15 kHz; AM: 1 kHz; m = 30%	–	50	–	dB
α <sub>FM</sub>	FM suppression for FM off	V <sub>ilF</sub> = 500 mV; V <sub>5</sub> = 3 V	80	–	–	dB
ΔV <sub>8,9</sub>	AFC shift in relation to minimum second harmonic distortion α <sub>2H</sub>	V <sub>ilF</sub> = 0.03 to 500 mV	–	25	–	mV
		operating	–	0	±100	mV
	DC offset at second harmonic distortion	mute or FM off	–	0	±50	mV
α <sub>3H</sub>	distortion for third harmonic		–	0.65	–	%
RR	ripple rejection V <sub>ripple</sub> = 200 mV on V <sub>P</sub>	f = 100 Hz	43	48	–	dB

FM/IF amplifier/demodulator circuit

TDA1576T

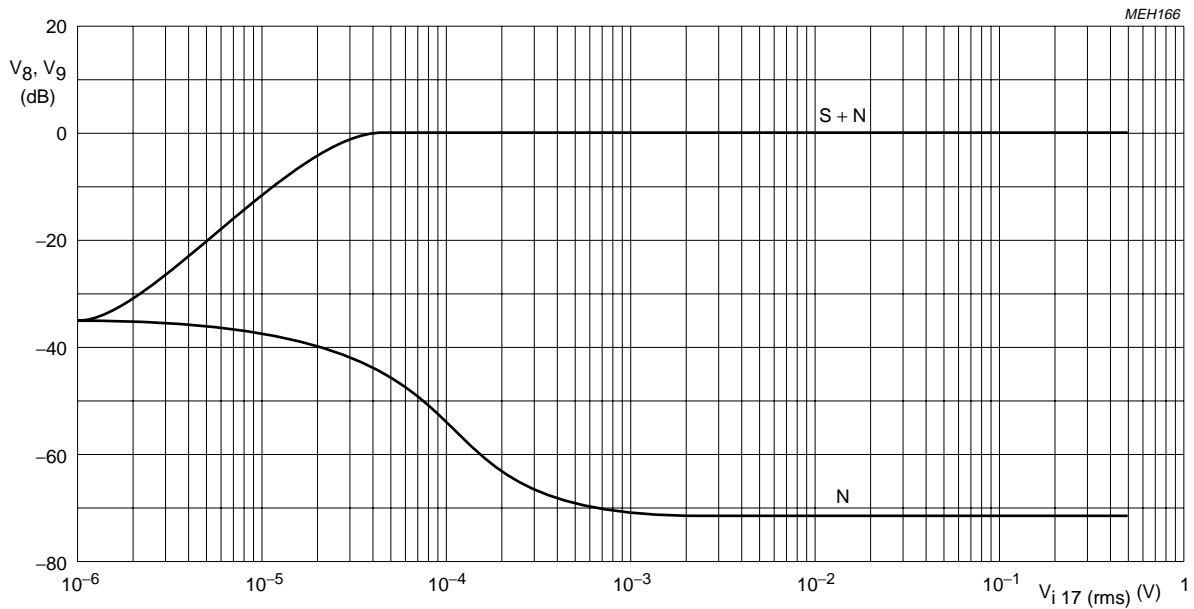

Fig.3 AF output voltage level on pins 8 and 9 as a function of  $V_{i17}$  at  $V_P = 8.5$  V;  $f_m = 1$  kHz;  $Q_L = 20$  with de-emphasis.

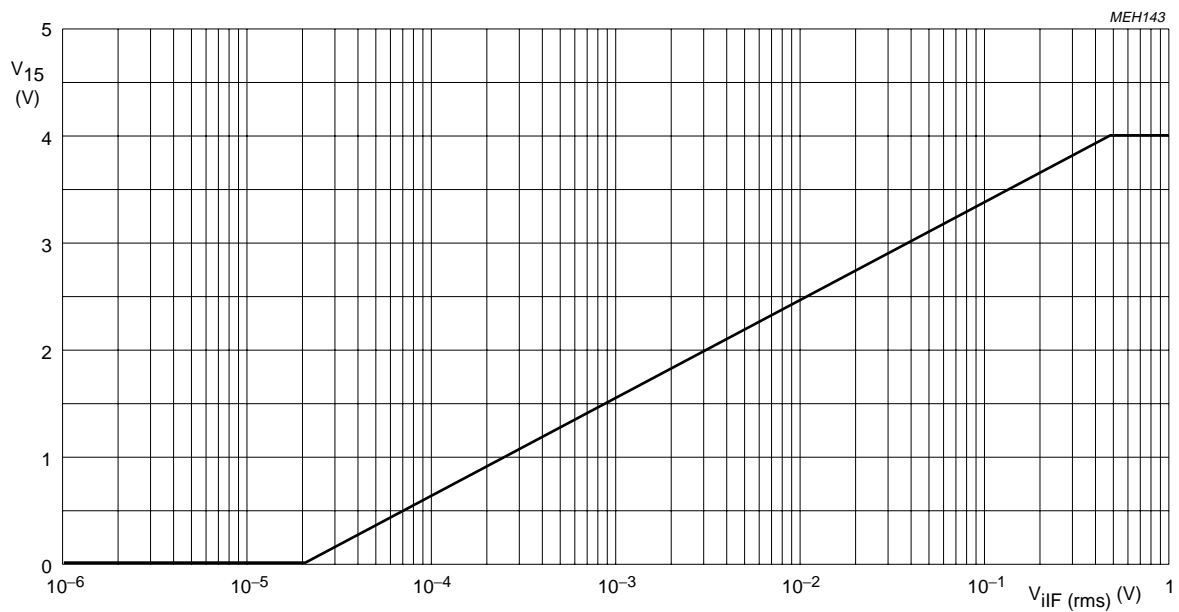
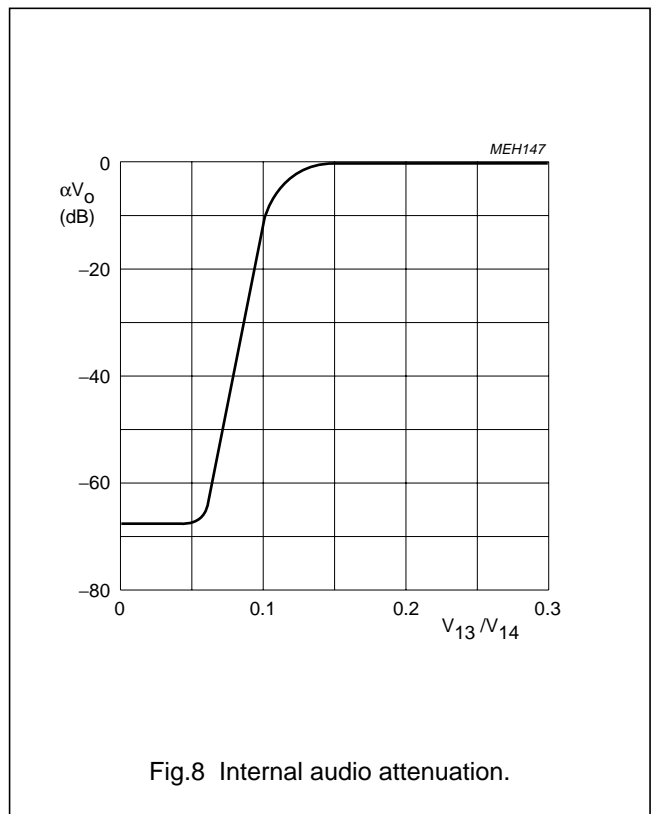
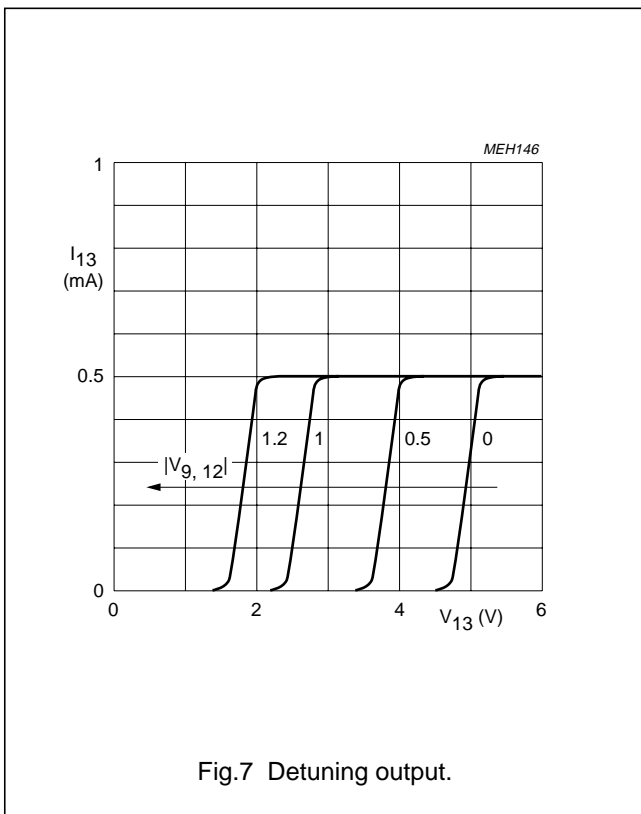
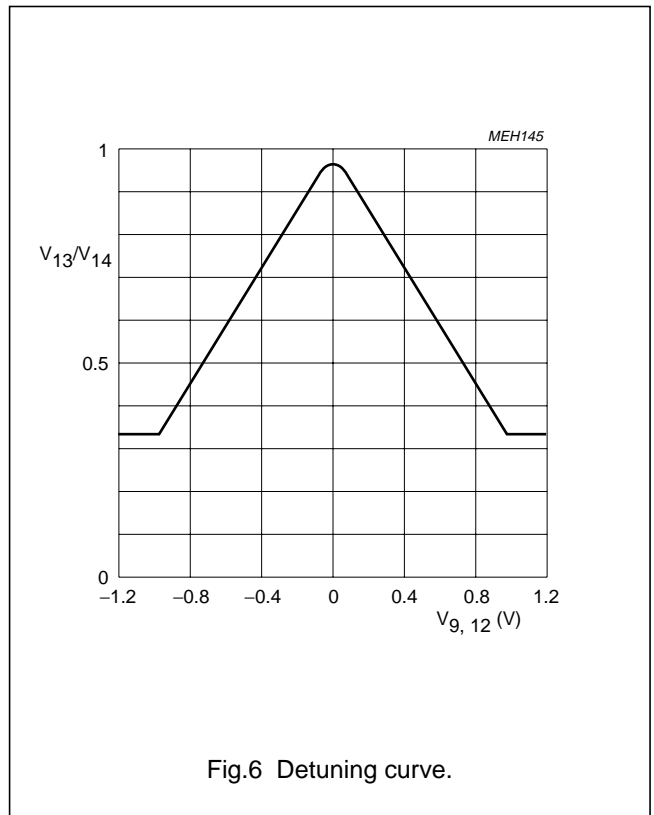
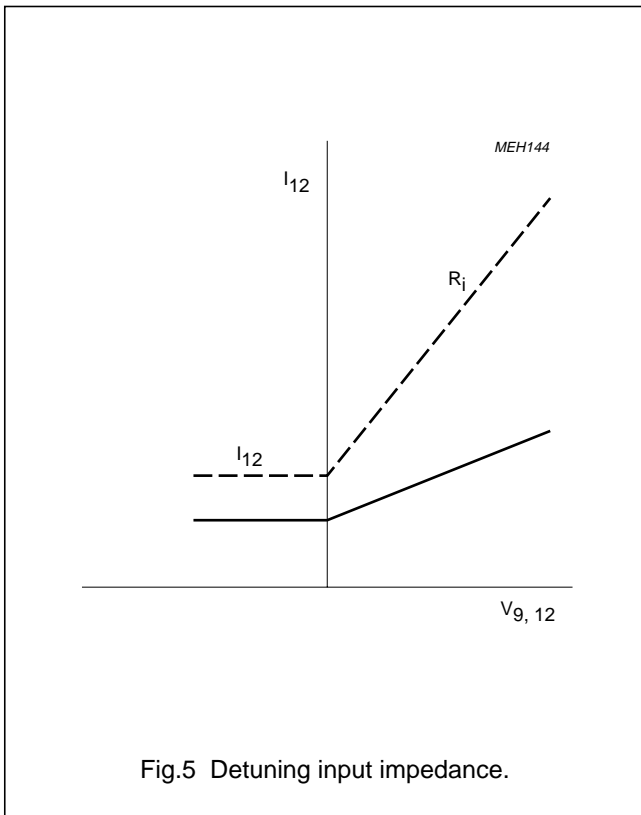

Fig.4 Field strength output ( $I_{16} = 0$ ).

FM/IF amplifier/demodulator circuit

TDA1576T



FM/IF amplifier/demodulator circuit

TDA1576T

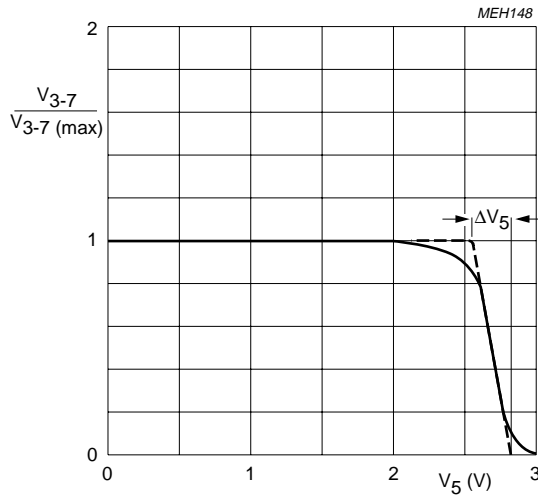
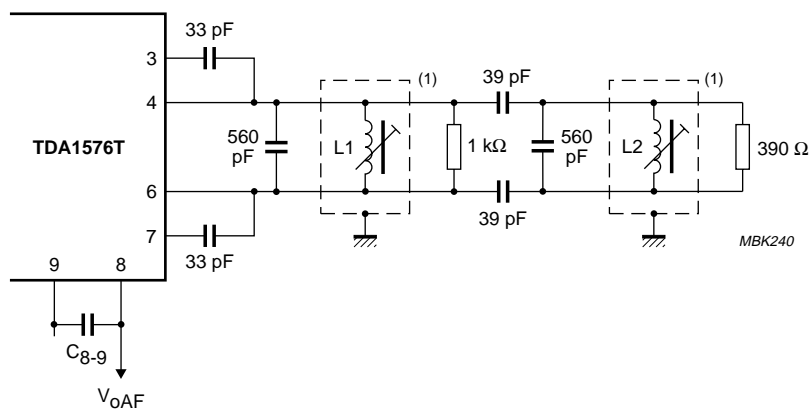

Fig.9 Standby switch.



Adjustment of the demodulator circuit is obtained with an IF signal which is higher than the 3 dB limiting level; L2 should be short-circuited or detuned; L1 should be adjusted to minimum  $d_2$  distortion, and then L2 to minimum  $d_2$  distortion.

(1) Coil data:  $L1 = L2 = 0.38 \mu\text{H}$ ;  $Q_0 = 70$ ; coil former KAN (C).

Fig.10 An example of the TDA1576T when using a demodulator with two tuned circuits.

FM/IF amplifier/demodulator circuit

TDA1576T

PACKAGE OUTLINE

SO20: plastic small outline package; 20 leads; body width 7.5 mm

SOT163-1

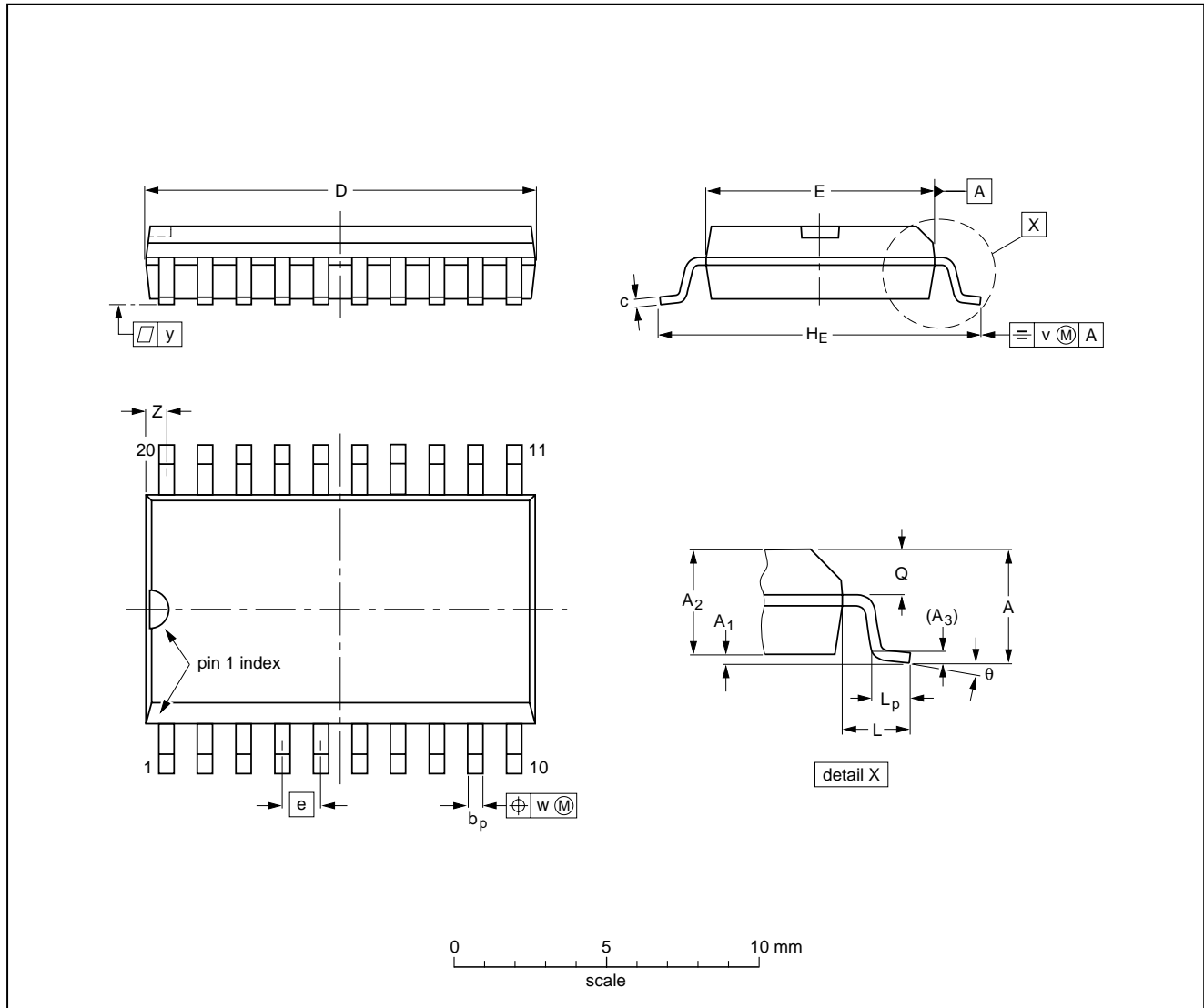

DIMENSIONS (inch dimensions are derived from the original mm dimensions)

UNIT	A max.	A <sub>1</sub>	A <sub>2</sub>	A <sub>3</sub>	b <sub>p</sub>	c	D <sup>(1)</sup>	E <sup>(1)</sup>	e	H <sub>E</sub>	L	L <sub>p</sub>	Q	v	w	y	z <sup>(1)</sup>	θ
mm	2.65	0.30 0.10	2.45 2.25	0.25	0.49 0.36	0.32 0.23	13.0 12.6	7.6 7.4	1.27	10.65 10.00	1.4	1.1 0.4	1.1 1.0	0.25	0.25	0.1	0.9 0.4	8° 0°
inches	0.10	0.012 0.004	0.096 0.089	0.01	0.019 0.014	0.013 0.009	0.51 0.49	0.30 0.29	0.050	0.419 0.394	0.055	0.043 0.016	0.043 0.039	0.01	0.01	0.004	0.035 0.016	

Note

1. Plastic or metal protrusions of 0.15 mm maximum per side are not included.

OUTLINE VERSION	REFERENCES				EUROPEAN PROJECTION	ISSUE DATE
	IEC	JEDEC	EIAJ			
SOT163-1	075E04	MS-013AC				95-01-24 97-05-22

## FM/IF amplifier/demodulator circuit

TDA1576T

### SOLDERING

#### Introduction to soldering surface mount packages

This text gives a very brief insight to a complex technology. A more in-depth account of soldering ICs can be found in our *"Data Handbook IC26; Integrated Circuit Packages"* (document order number 9398 652 90011).

There is no soldering method that is ideal for all surface mount IC packages. Wave soldering is not always suitable for surface mount ICs, or for printed-circuit boards with high population densities. In these situations reflow soldering is often used.

#### Reflow soldering

Reflow soldering requires solder paste (a suspension of fine solder particles, flux and binding agent) to be applied to the printed-circuit board by screen printing, stencilling or pressure-syringe dispensing before package placement.

Several methods exist for reflowing; for example, infrared/convection heating in a conveyor type oven. Throughput times (preheating, soldering and cooling) vary between 100 and 200 seconds depending on heating method.

Typical reflow peak temperatures range from 215 to 250 °C. The top-surface temperature of the packages should preferably be kept below 230 °C.

#### Wave soldering

Conventional single wave soldering is not recommended for surface mount devices (SMDs) or printed-circuit boards with a high component density, as solder bridging and non-wetting can present major problems.

To overcome these problems the double-wave soldering method was specifically developed.

If wave soldering is used the following conditions must be observed for optimal results:

- Use a double-wave soldering method comprising a turbulent wave with high upward pressure followed by a smooth laminar wave.
- For packages with leads on two sides and a pitch (e):
  - larger than or equal to 1.27 mm, the footprint longitudinal axis is **preferred** to be parallel to the transport direction of the printed-circuit board;
  - smaller than 1.27 mm, the footprint longitudinal axis **must** be parallel to the transport direction of the printed-circuit board.

The footprint must incorporate solder thieves at the downstream end.

- For packages with leads on four sides, the footprint must be placed at a 45° angle to the transport direction of the printed-circuit board. The footprint must incorporate solder thieves downstream and at the side corners.

During placement and before soldering, the package must be fixed with a droplet of adhesive. The adhesive can be applied by screen printing, pin transfer or syringe dispensing. The package can be soldered after the adhesive is cured.

Typical dwell time is 4 seconds at 250 °C.

A mildly-activated flux will eliminate the need for removal of corrosive residues in most applications.

#### Manual soldering

Fix the component by first soldering two diagonally-opposite end leads. Use a low voltage (24 V or less) soldering iron applied to the flat part of the lead. Contact time must be limited to 10 seconds at up to 300 °C.

When using a dedicated tool, all other leads can be soldered in one operation within 2 to 5 seconds between 270 and 320 °C.

## FM/IF amplifier/demodulator circuit

TDA1576T

## Suitability of surface mount IC packages for wave and reflow soldering methods

PACKAGE	SOLDERING METHOD	
	WAVE	REFLOW <sup>(1)</sup>
BGA, SQFP	not suitable	suitable
HLQFP, HSQFP, HSOP, SMS	not suitable <sup>(2)</sup>	suitable
PLCC <sup>(3)</sup> , SO, SOJ	suitable	suitable
LQFP, QFP, TQFP	not recommended <sup>(3)(4)</sup>	suitable
SSOP, TSSOP, VSO	not recommended <sup>(5)</sup>	suitable

## Notes

- All surface mount (SMD) packages are moisture sensitive. Depending upon the moisture content, the maximum temperature (with respect to time) and body size of the package, there is a risk that internal or external package cracks may occur due to vaporization of the moisture in them (the so called popcorn effect). For details, refer to the Drypack information in the "Data Handbook IC26; Integrated Circuit Packages; Section: Packing Methods".
- These packages are not suitable for wave soldering as a solder joint between the printed-circuit board and heatsink (at bottom version) can not be achieved, and as solder may stick to the heatsink (on top version).
- If wave soldering is considered, then the package must be placed at a 45° angle to the solder wave direction. The package footprint must incorporate solder thieves downstream and at the side corners.
- Wave soldering is only suitable for LQFP, TQFP and QFP packages with a pitch (e) equal to or larger than 0.8 mm; it is definitely not suitable for packages with a pitch (e) equal to or smaller than 0.65 mm.
- Wave soldering is only suitable for SSOP and TSSOP packages with a pitch (e) equal to or larger than 0.65 mm; it is definitely not suitable for packages with a pitch (e) equal to or smaller than 0.5 mm.

## DEFINITIONS

Data sheet status	
Objective specification	This data sheet contains target or goal specifications for product development.
Preliminary specification	This data sheet contains preliminary data; supplementary data may be published later.
Product specification	This data sheet contains final product specifications.
Limiting values	
Limiting values given are in accordance with the Absolute Maximum Rating System (IEC 134). Stress above one or more of the limiting values may cause permanent damage to the device. These are stress ratings only and operation of the device at these or at any other conditions above those given in the Characteristics sections of the specification is not implied. Exposure to limiting values for extended periods may affect device reliability.	
Application information	
Where application information is given, it is advisory and does not form part of the specification.	

## LIFE SUPPORT APPLICATIONS

These products are not designed for use in life support appliances, devices, or systems where malfunction of these products can reasonably be expected to result in personal injury. Philips customers using or selling these products for use in such applications do so at their own risk and agree to fully indemnify Philips for any damages resulting from such improper use or sale.

FM/IF amplifier/demodulator circuit

TDA1576T

---

**NOTES**

# Philips Semiconductors – a worldwide company

**Argentina:** see South America

**Australia:** 34 Waterloo Road, NORTH RYDE, NSW 2113, Tel. +61 2 9805 4455, Fax. +61 2 9805 4466

**Austria:** Computerstr. 6, A-1101 WIEN, P.O. Box 213, Tel. +43 160 1010, Fax. +43 160 101 1210

**Belarus:** Hotel Minsk Business Center, Bld. 3, r. 1211, Volodarski Str. 6, 220050 MINSK, Tel. +375 172 200 733, Fax. +375 172 200 773

**Belgium:** see The Netherlands

**Brazil:** see South America

**Bulgaria:** Philips Bulgaria Ltd., Energoproject, 15th floor, 51 James Bourchier Blvd., 1407 SOFIA, Tel. +359 2 689 211, Fax. +359 2 689 102

**Canada:** PHILIPS SEMICONDUCTORS/COMPONENTS, Tel. +1 800 234 7381

**China/Hong Kong:** 501 Hong Kong Industrial Technology Centre, 72 Tat Chee Avenue, Kowloon Tong, HONG KONG, Tel. +852 2319 7888, Fax. +852 2319 7700

**Colombia:** see South America

**Czech Republic:** see Austria

**Denmark:** Prags Boulevard 80, PB 1919, DK-2300 COPENHAGEN S, Tel. +45 32 88 2636, Fax. +45 31 57 0044

**Finland:** Sinikalliontie 3, FIN-02630 ESPOO, Tel. +358 9 615800, Fax. +358 9 61580920

**France:** 51 Rue Carnot, BP317, 92156 SURESNES Cedex, Tel. +33 1 40 99 6161, Fax. +33 1 40 99 6427

**Germany:** Hammerbrookstraße 69, D-20097 HAMBURG, Tel. +49 40 23 53 60, Fax. +49 40 23 536 300

**Greece:** No. 15, 25th March Street, GR 17778 TAVROS/ATHENS, Tel. +30 1 4894 339/239, Fax. +30 1 4814 240

**Hungary:** see Austria

**India:** Philips INDIA Ltd, Band Box Building, 2nd floor, 254-D, Dr. Annie Besant Road, Worli, MUMBAI 400 025, Tel. +91 22 493 8541, Fax. +91 22 493 0966

**Indonesia:** PT Philips Development Corporation, Semiconductors Division, Gedung Philips, Jl. Buncit Raya Kav.99-100, JAKARTA 12510, Tel. +62 21 794 0040 ext. 2501, Fax. +62 21 794 0080

**Ireland:** Newstead, Clonskeagh, DUBLIN 14, Tel. +353 1 7640 000, Fax. +353 1 7640 200

**Israel:** RAPAC Electronics, 7 Kehilat Saloniki St, PO Box 18053, TEL AVIV 61180, Tel. +972 3 645 0444, Fax. +972 3 649 1007

**Italy:** PHILIPS SEMICONDUCTORS, Piazza IV Novembre 3, 20124 MILANO, Tel. +39 2 6752 2531, Fax. +39 2 6752 2557

**Japan:** Philips Bldg 13-37, Kohnan 2-chome, Minato-ku, TOKYO 108-8507, Tel. +81 3 3740 5130, Fax. +81 3 3740 5077

**Korea:** Philips House, 260-199 Itaewon-dong, Yongsan-ku, SEOUL, Tel. +82 2 709 1412, Fax. +82 2 709 1415

**Malaysia:** No. 76 Jalan Universiti, 46200 PETALING JAYA, SELANGOR, Tel. +60 3 750 5214, Fax. +60 3 757 4880

**Mexico:** 5900 Gateway East, Suite 200, EL PASO, TEXAS 79905, Tel. +9-5 800 234 7381

**Middle East:** see Italy

**Netherlands:** Postbus 90050, 5600 PB EINDHOVEN, Bldg. VB, Tel. +31 40 27 82785, Fax. +31 40 27 88399

**New Zealand:** 2 Wagener Place, C.P.O. Box 1041, AUCKLAND, Tel. +64 9 849 4160, Fax. +64 9 849 7811

**Norway:** Box 1, Manglerud 0612, OSLO, Tel. +47 22 74 8000, Fax. +47 22 74 8341

**Pakistan:** see Singapore

**Philippines:** Philips Semiconductors Philippines Inc., 106 Valero St. Salcedo Village, P.O. Box 2108 MCC, MAKATI, Metro MANILA, Tel. +63 2 816 6380, Fax. +63 2 817 3474

**Poland:** Ul. Lukiska 10, PL 04-123 WARSZAWA, Tel. +48 22 612 2831, Fax. +48 22 612 2327

**Portugal:** see Spain

**Romania:** see Italy

**Russia:** Philips Russia, Ul. Usatcheva 35A, 119048 MOSCOW, Tel. +7 095 755 6918, Fax. +7 095 755 6919

**Singapore:** Lorong 1, Toa Payoh, SINGAPORE 319762, Tel. +65 350 2538, Fax. +65 251 6500

**Slovakia:** see Austria

**Slovenia:** see Italy

**South Africa:** S.A. PHILIPS Pty Ltd., 195-215 Main Road Martindale, 2092 JOHANNESBURG, P.O. Box 7430 Johannesburg 2000, Tel. +27 11 470 5911, Fax. +27 11 470 5494

**South America:** Al. Vicente Pinzon, 173, 6th floor, 04547-130 SÃO PAULO, SP, Brazil, Tel. +55 11 821 2333, Fax. +55 11 821 2382

**Spain:** Balmes 22, 08007 BARCELONA, Tel. +34 93 301 6312, Fax. +34 93 301 4107

**Sweden:** Kottbygatan 7, Akalla, S-16485 STOCKHOLM, Tel. +46 8 5985 2000, Fax. +46 8 5985 2745

**Switzerland:** Allmendstrasse 140, CH-8027 ZÜRICH, Tel. +41 1 488 2741 Fax. +41 1 488 3263

**Taiwan:** Philips Semiconductors, 6F, No. 96, Chien Kuo N. Rd., Sec. 1, TAIPEI, Taiwan Tel. +886 2 2134 2865, Fax. +886 2 2134 2874

**Thailand:** PHILIPS ELECTRONICS (THAILAND) Ltd., 209/2 Sanpavuth-Bangna Road Prakanong, BANGKOK 10260, Tel. +66 2 745 4090, Fax. +66 2 398 0793

**Turkey:** Talatpasa Cad. No. 5, 80640 GÜLTEPE/ISTANBUL, Tel. +90 212 279 2770, Fax. +90 212 282 6707

**Ukraine:** PHILIPS UKRAINE, 4 Patrice Lumumba str., Building B, Floor 7, 252042 KIEV, Tel. +380 44 264 2776, Fax. +380 44 268 0461

**United Kingdom:** Philips Semiconductors Ltd., 276 Bath Road, Hayes, MIDDLESEX UB3 5BX, Tel. +44 181 730 5000, Fax. +44 181 754 8421

**United States:** 811 East Arques Avenue, SUNNYVALE, CA 94088-3409, Tel. +1 800 234 7381

**Uruguay:** see South America

**Vietnam:** see Singapore

**Yugoslavia:** PHILIPS, Trg N. Pasica 5/v, 11000 BEOGRAD, Tel. +381 11 625 344, Fax. +381 11 635 777

**For all other countries apply to:** Philips Semiconductors, International Marketing & Sales Communications, Building BE-p, P.O. Box 218, 5600 MD EINDHOVEN, The Netherlands, Fax. +31 40 27 24825

**Internet:** <http://www.semiconductors.philips.com>

© Philips Electronics N.V. 1998

SCA60

All rights are reserved. Reproduction in whole or in part is prohibited without the prior written consent of the copyright owner.

The information presented in this document does not form part of any quotation or contract, is believed to be accurate and reliable and may be changed without notice. No liability will be accepted by the publisher for any consequence of its use. Publication thereof does not convey nor imply any license under patent- or other industrial or intellectual property rights.

Printed in The Netherlands

545102/750/02/pp16

Date of release: 1998 Nov 18

Document order number: 9397 750 04823

*Let's make things better.*

**Philips  
Semiconductors**



**PHILIPS**