

LOW NOISE STEREO PREAMPLIFIER

PRODUCT PREVIEW

- DUAL CHANNEL PROCESSOR FOR PLAY-BACK APPLICATIONS.
- LOW NOISE HEAD PREAMPLIFIER GROUND COMPATIBLE
- MUTE, AUTOREVERSE METAL/NORMAL FUNCTIONS
- INTERNAL SWITCHES FOR EQUALIZATION
- LOW SUPPLY CURRENT
- MIXED BIPOLAR/CMOS TECHNOLOGY

DESCRIPTION

The TDA7334 is a monolithic BiCMos IC designed for use in stereo cassette player systems.

The dual preamplifier contains mute, autoreverse, metal/normal facilities for amplification of low level signal in applications requiring very low noise performance.

Each channel consists of two cascaded operational amplifiers.

The first one, AMP1, has a fixed gain of 32dB,

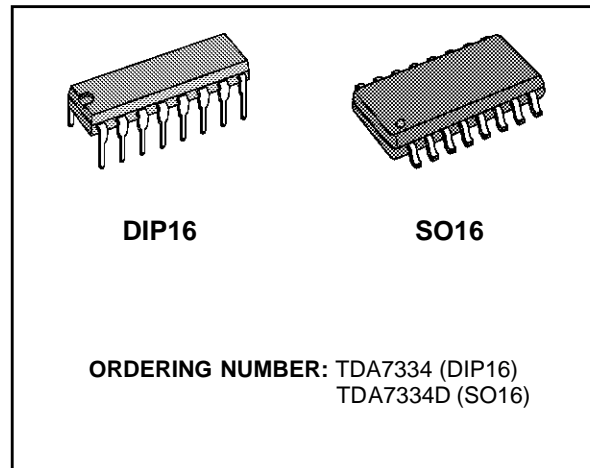

low noise forward/reverse switchable input, and allows magnetic heads connection directly to ground. The second one, AMP2, is a standard operational amplifier whose equalizing external components fix the frequency response.

TEST CIRCUIT

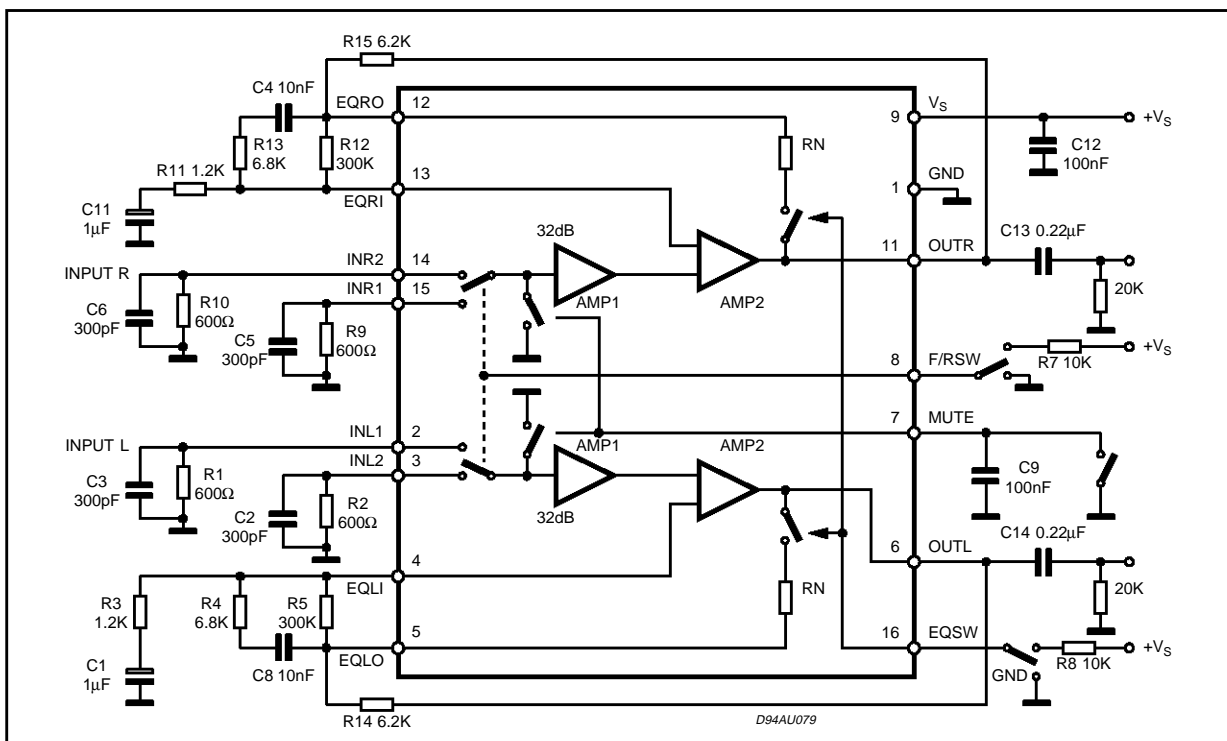

TDA7334

ABSOLUTE MAXIMUM RATINGS

Symbol	Parameter	Value	Unit
V _s	Supply Voltage	12	V
P _{tot}	Total Power Dissipation	1	W
T _{op}	Operating Temperature Range	-40 to 85	°C
T _{stg}	Storage Temperature Range	-40 to 150	°C

PIN CONNECTION (Top view)

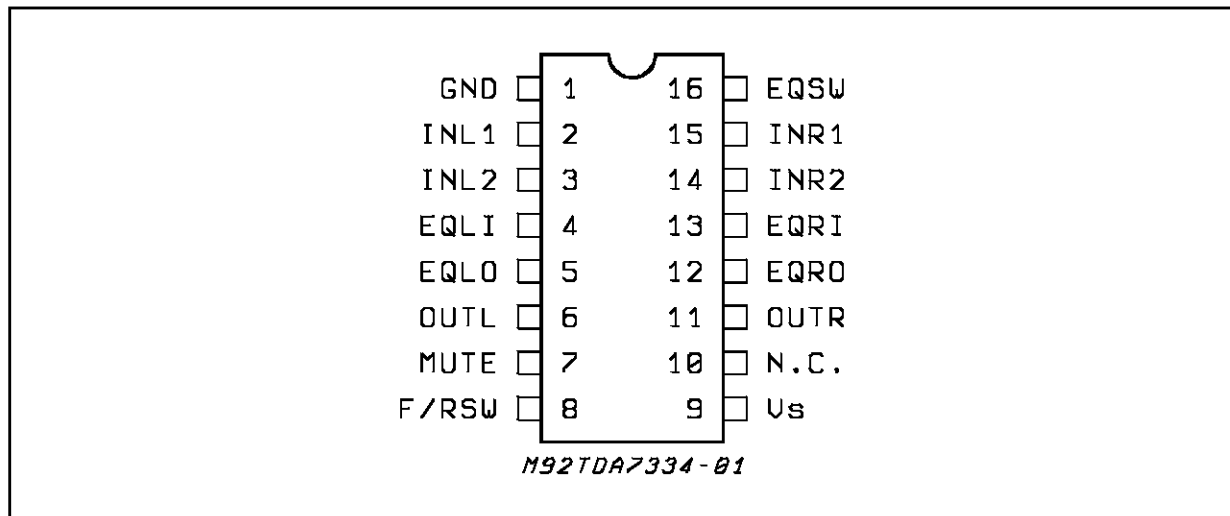

THERMAL DATA

		DIP 16	SO16	
R _{th j-pins}	Thermal resistance junction-pins	100	200	°C/W

Figure 1: Application Circuit

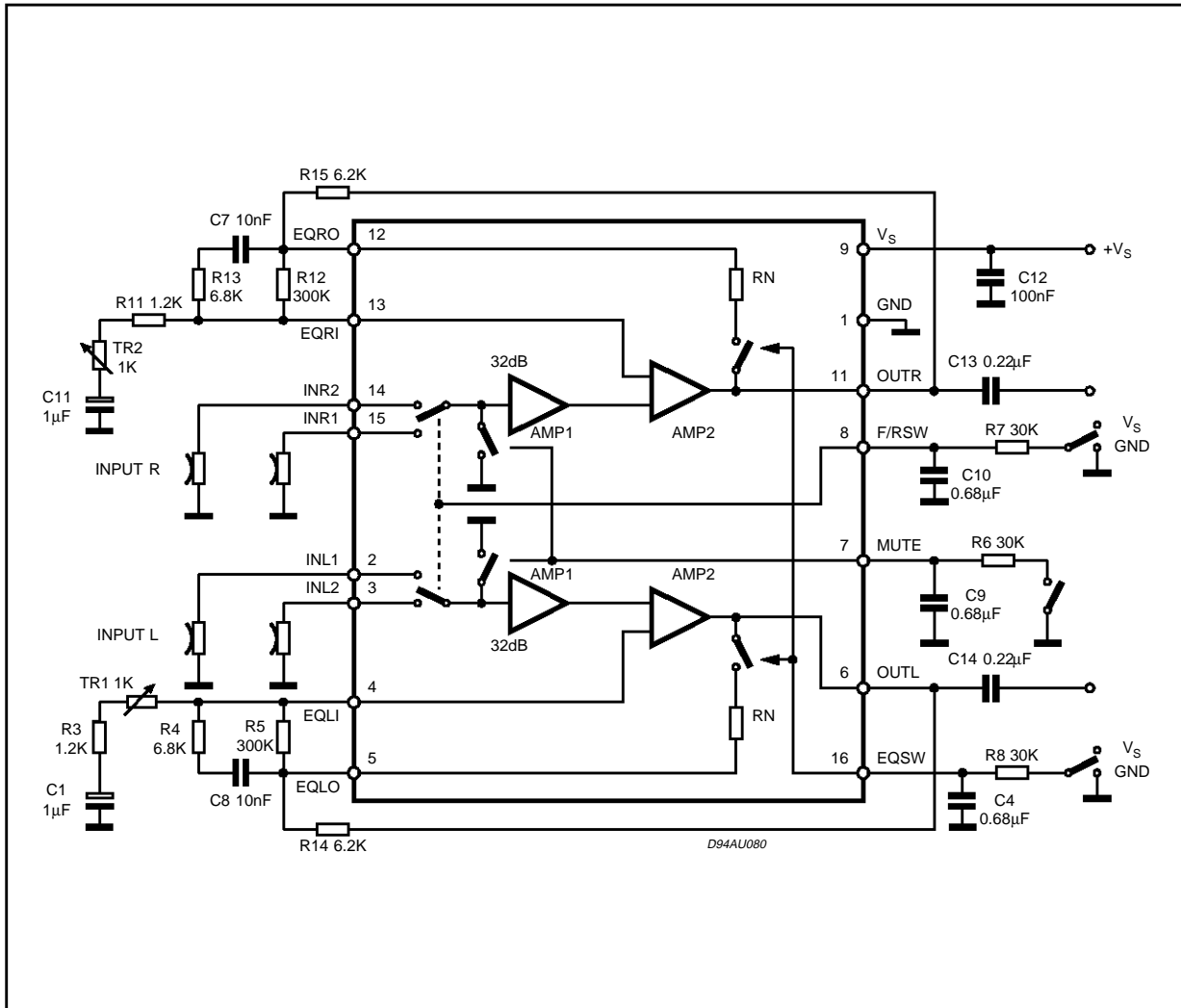

PIN	1	2	3	4	5	6	7	8	9	10	11	12	13	14	15	16
DC (V)	GND	0	0	3.6	3.6	3.6			8.0	N.C.	3.6	3.6	3.6	0	0	

TDA7334

ELECTRICAL CHARACTERISTICS ($V_s = 8V$; $R_{IN} = 600\Omega$; $f = 1KHz$; $T_{amb} = 25^\circ C$; unless otherwise specified (see figure 2))

Symbol	Parameter	Test Condition	Min.	Typ.	Max.	Unit
V_s	Supply Voltage		6	8	11	V
I_s	Supply Current			7.5		mA
SVR	Ripple Rejection	Input referred (ripple = 1V)		105		dB
MUTE _{th}	Mute (Pin 7)	OFF ON	0 3.2		0.8 V_s	V V
MUTE _A	Mute Attenuation			80		dB
R_I	Input Resistance		100			K Ω
$V_{out DC}$	Output Voltage DC			3.6		V
I_I	Input Bias Current				10	μA
G_{VO}	Open Loop Gain	$f = 400Hz$		110		dB
G_V	Closed Loop Gain	NAB short		32		dB
ΔG_V	Closed Loop Gain Match	NAB short	-1		1	dB
V_{OM}	Signal Handling	THD = 1%, $V_{CC} = 7.6V$		2.0		V _{rms}
R_N	Resistance Normal Position				700	Ω
S_R	Slew Rate	NAB Short		1		V/ μs
e_N	Total Input Noise	$R_{IN} = 600\Omega$; unweighted		0.8		μV
		$R_{IN} = 600\Omega$; A weighted		0.5		μV
		$R_{IN} = 0$; unweighted		0.45		μV
R_o	Output Resistance				1	K Ω
L_{Omin}	Minimum Resistance Load			1		K Ω
F/R _l	Rev. Low Level (pin 8)	IN2 = ON; IN1 = OFF	0		0.8	V
F/R _h	Forward High Level (pin 8)	IN2 = OFF; IN1 = ON	3.2		V_s	V
EQ _l	Normal Low Level (pin 16)		0		0.8	V
EQ _h	Metal High Level (pin 16)		3.2		V_s	V
THD	Total Harmonic Distortion	$V_o = 1V$; $f = 1KHz$ metal		0.02		%
		$V_o = 1V$; $f = 1KHz$ normal		0.02		%
		$V_o = 1V$; $f = 10KHz$ metal		0.05		%
		$V_o = 1V$; $f = 10KHz$ normal		0.04		%
SVR ₁	Ripple Rejection	NAB short		75		dB
C_s	Channel Separation			60		dB
C_{CT}	Channel Cross talk			80		dB
S/N	Signal to Noise	$V_o = 388mV$; metal		63		dB

Figure 1: Quiescent Current vs. Supply

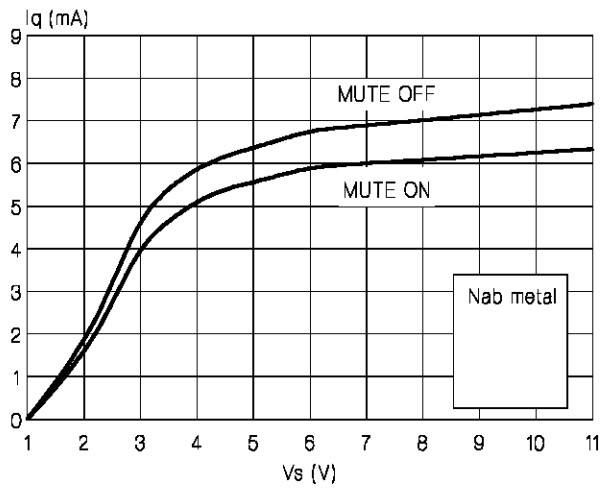

Figure 2: D.C. Output vs. Supply Voltage

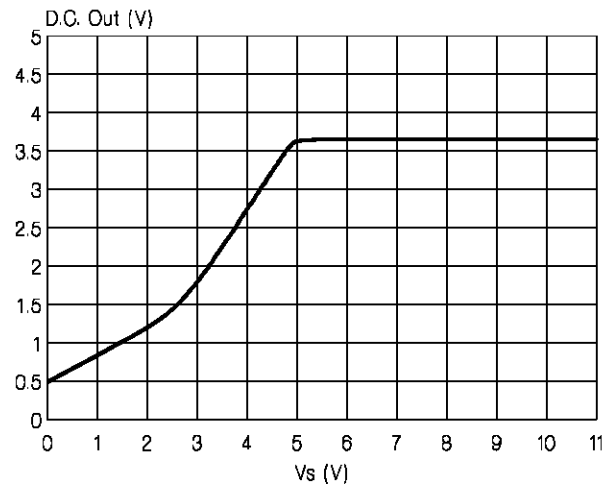

Figure 3: Forward/Reverse Threshold

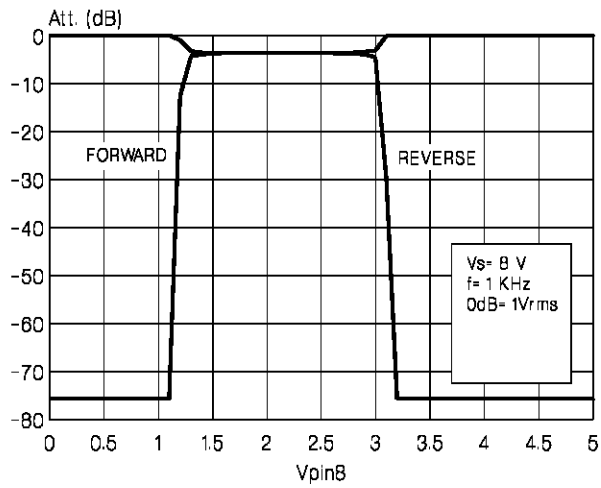

Figure 4: Metal/Normal Threshold

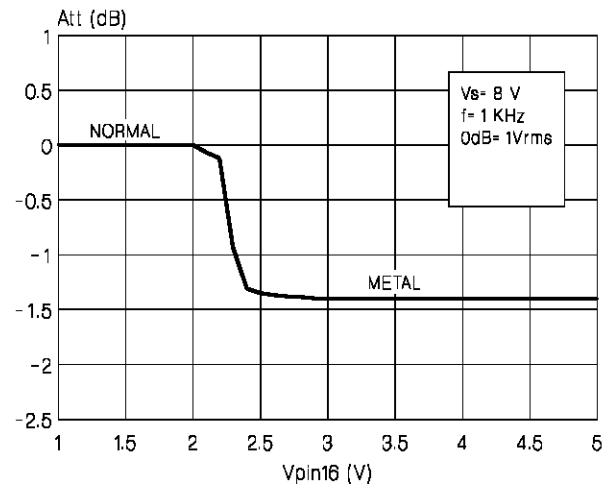

Figure 5: Mute Threshold

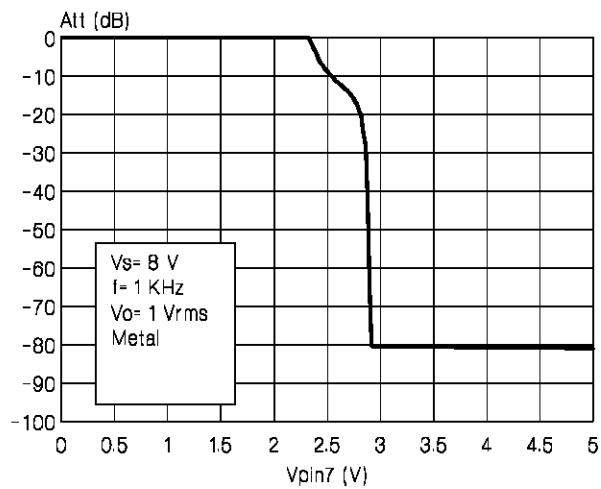

Figure 6: Mute Attenuation vs. Frequency

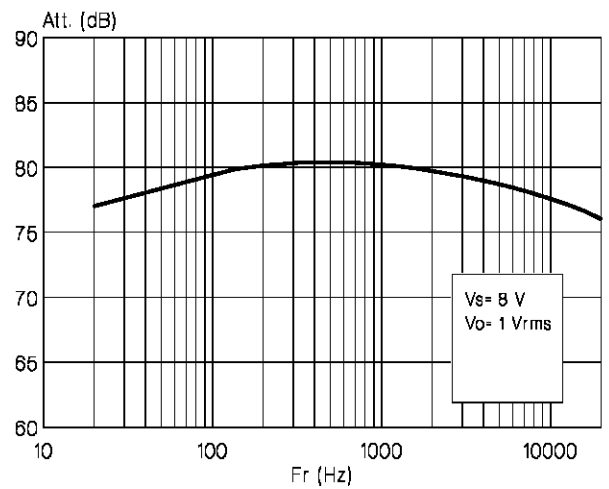

Figure 7: Mute Attenuation vs. Output Level

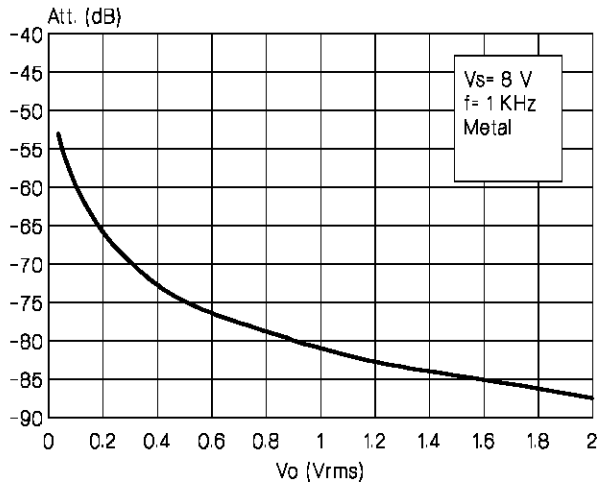

Figure 9: THD + N vs. Frequency

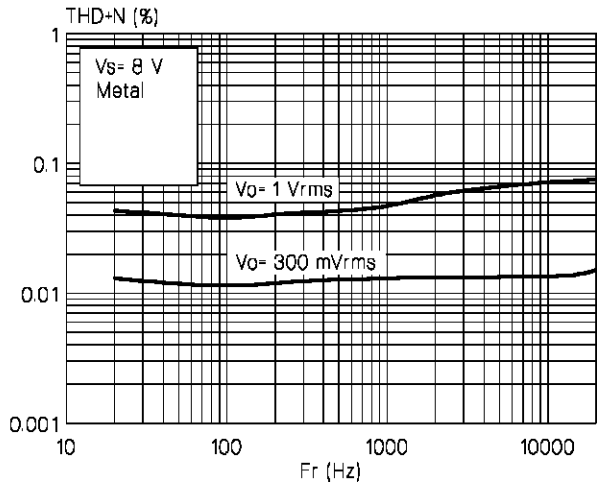

Figure 11: Load Characteristic

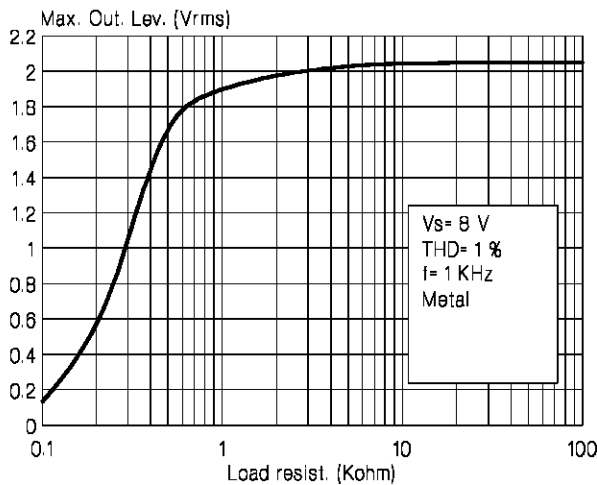

Figure 8: THD vs. Frequency

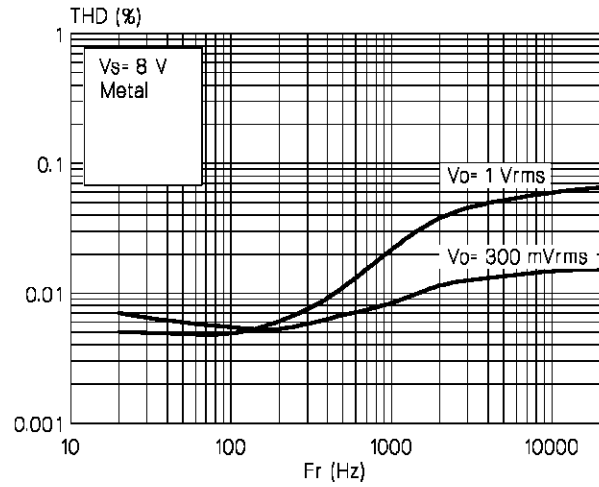

Figure 10: THD vs. Supply Voltage

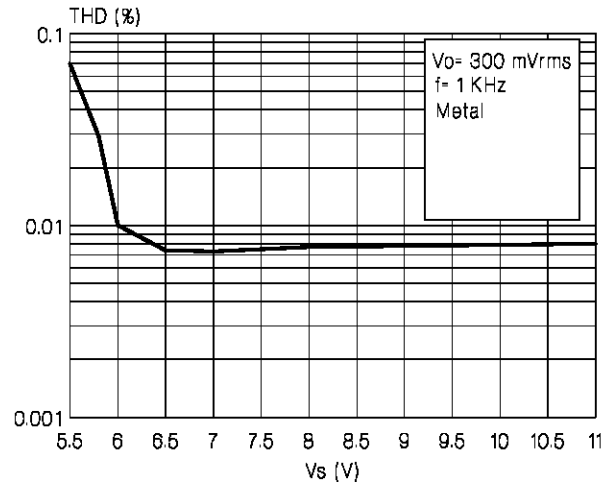

Figure 12: Signal Handling vs. Supply Voltage

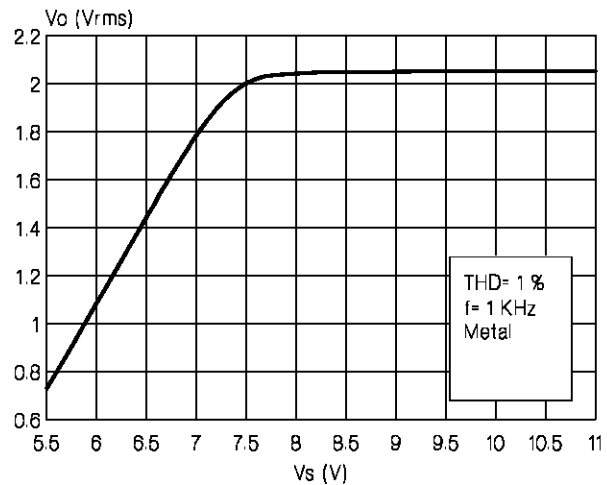

Figure 13: Total Input Noise vs. Input Resistance

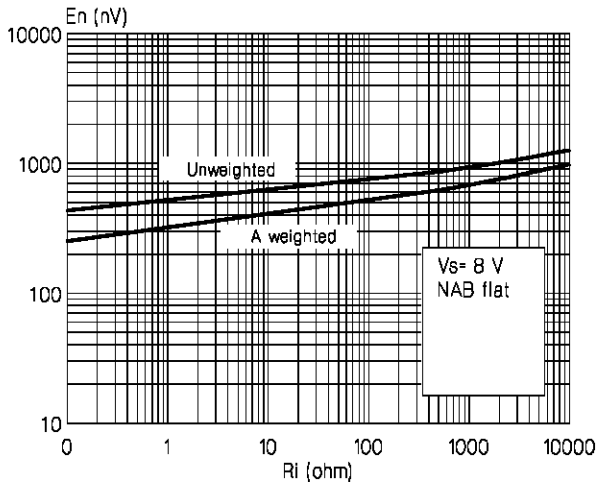

Figure 14: Cross Channel vs. Frequency

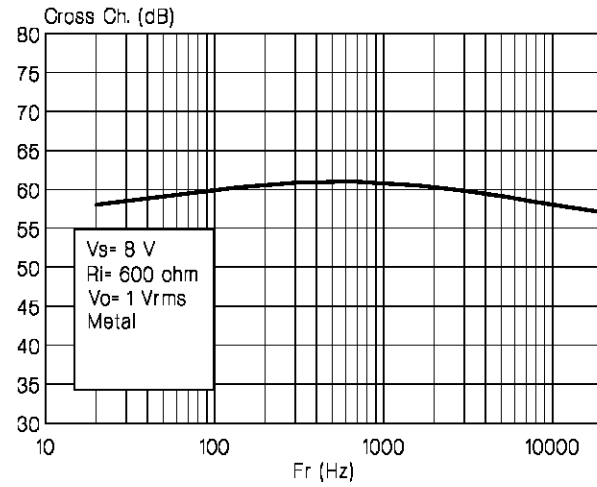

Figure 15: Cross Talk vs. Frequency

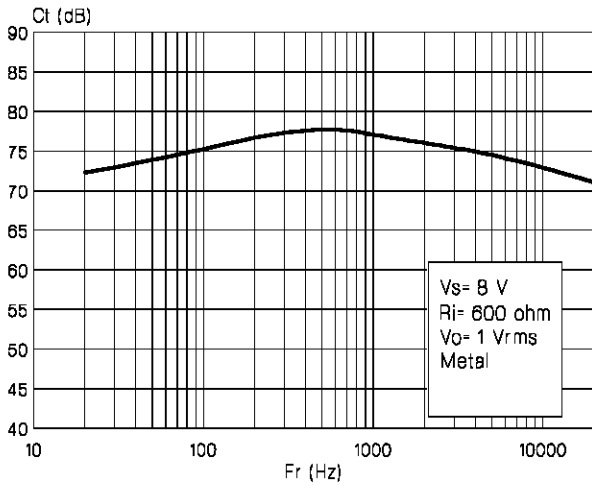

Figure 16: SVR vs. Frequency

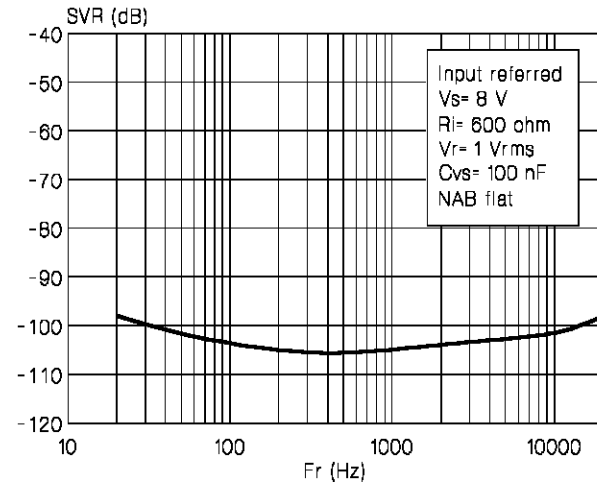

Figure 17: SVR vs. Frequency

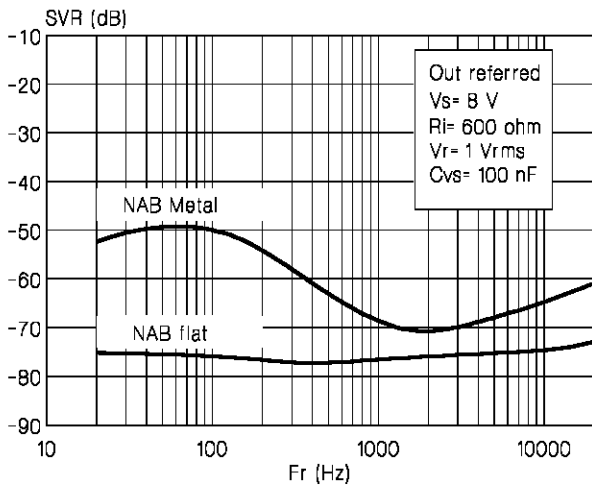

Figure 18: Power Bandwidth

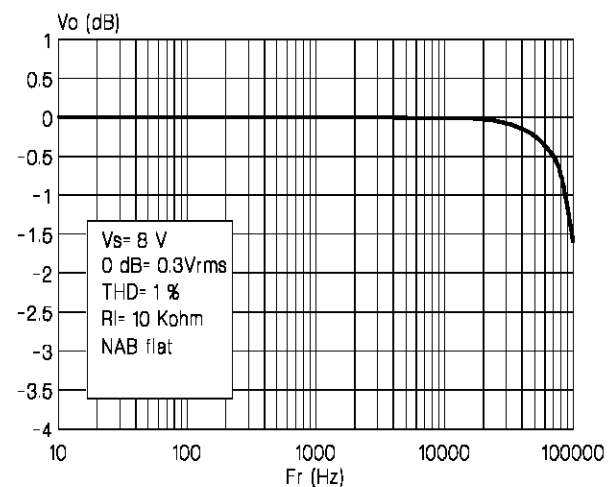

Figure 19: Voltage Gain vs. Input Voltage

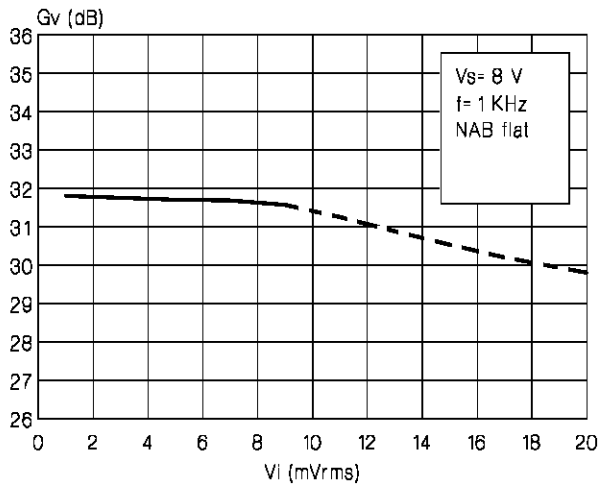
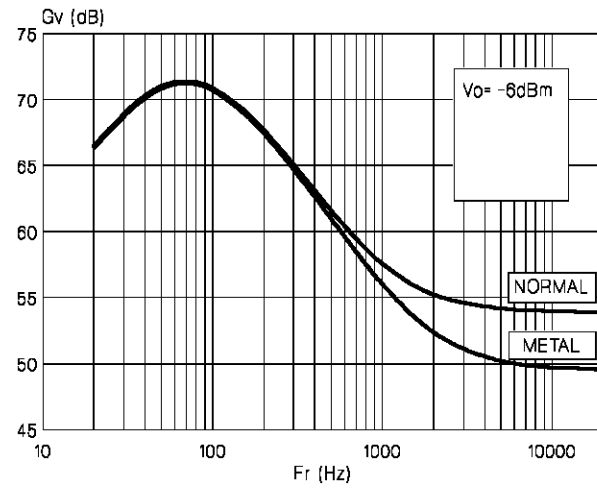
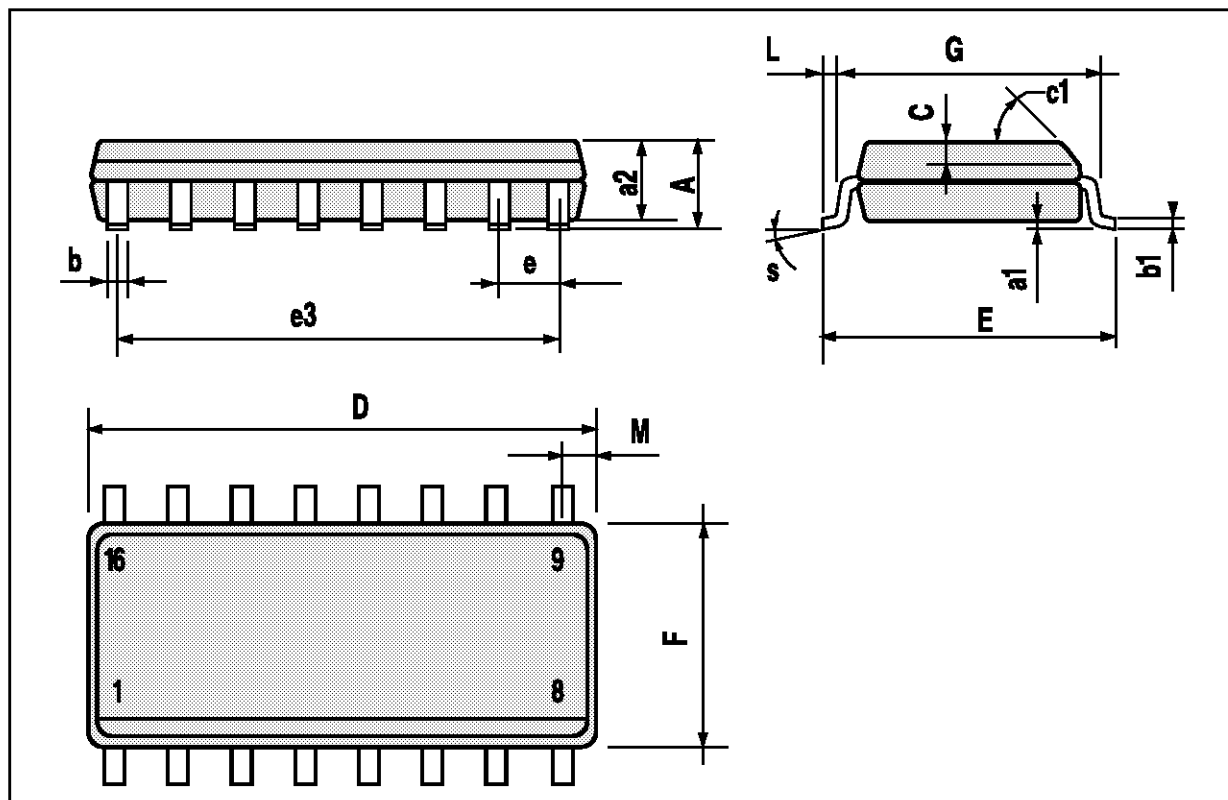

Figure 20: NAB Network



SO16 PACKAGE MECHANICAL DATA

DIM.	mm			inch		
	MIN.	TYP.	MAX.	MIN.	TYP.	MAX.
A			1.75			0.069
a1	0.1		0.25	0.004		0.009
a2			1.6			0.063
b	0.35		0.46	0.014		0.018
b1	0.19		0.25	0.007		0.010
C		0.5			0.020	
c1	45 (typ.)					
D	9.8		10	0.386		0.394
E	5.8		6.2	0.228		0.244
e		1.27			0.050	
e3		8.89			0.350	
F	3.8		4.0	0.150		0.157
L	0.4		1.27	0.016		0.050
M			0.62			0.024
S	8 (max.)					



TDA7334

DIP16 PACKAGE MECHANICAL DATA

DIM.	mm			inch		
	MIN.	TYP.	MAX.	MIN.	TYP.	MAX.
a1	0.51			0.020		
B	0.77		1.65	0.030		0.065
b		0.5			0.020	
b1		0.25			0.010	
D			20			0.787
E		8.5			0.335	
e		2.54			0.100	
e3		17.78			0.700	
F			7.1			0.280
I			5.1			0.201
L		3.3			0.130	
Z			1.27			0.050

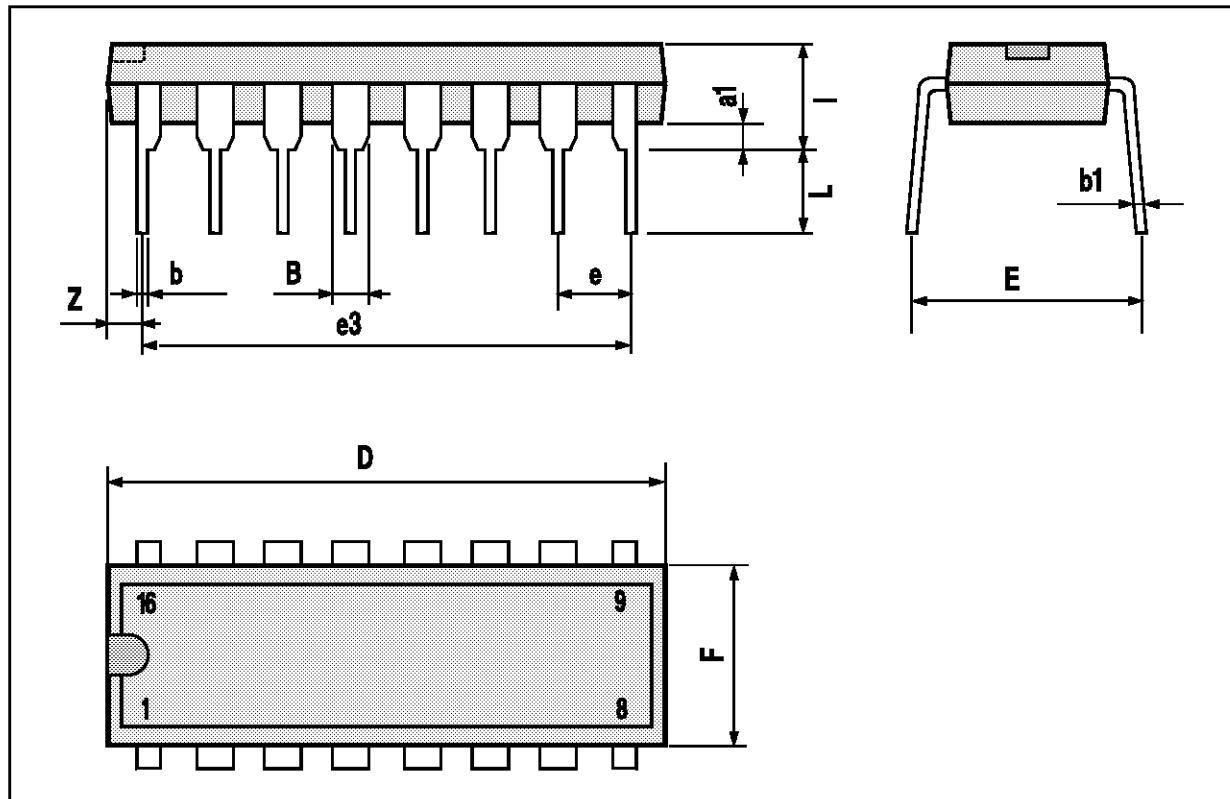

Information furnished is believed to be accurate and reliable. However, SGS-THOMSON Microelectronics assumes no responsibility for the consequences of use of such information nor for any infringement of patents or other rights of third parties which may result from its use. No license is granted by implication or otherwise under any patent or patent rights of SGS-THOMSON Microelectronics. Specifications mentioned in this publication are subject to change without notice. This publication supersedes and replaces all information previously supplied. SGS-THOMSON Microelectronics products are not authorized for use as critical components in life support devices or systems without express written approval of SGS-THOMSON Microelectronics.

© 1994 SGS-THOMSON Microelectronics - All Rights Reserved

SGS-THOMSON Microelectronics GROUP OF COMPANIES
Australia - Brazil - France - Germany - Hong Kong - Italy - Japan - Korea - Malaysia - Malta - Morocco - The Netherlands - Singapore -
Spain - Sweden - Switzerland - Taiwan - Thailand - United Kingdom - U.S.A.