

**ADVANCED 3-HEAD PLAY-BACK
AND RECORD AMPLIFIER FOR VCR**

PLAY-BACK MODE

- LOW NOISE AND WIDE BAND AMPLIFIERS FOR 3 HEADS
- AUTOMATIC OFFSET CANCELLATION BETWEEN THE 3 SELECTED HEADS
- ONE PLAY-BACK OUTPUT WITHOUT AGC
- ONE PLAY-BACK OUTPUT INCLUDING AGC (OPPOSITE PHASE)
- RECORD AMPLIFIER INHIBITION AND RECORD OUTPUT GROUNDED
- OUTPUT FOR TRACKING VIDEO INFORMATION (TRIV)

RECORD MODE

- ONE INTEGRATED I/I CONVERTER WITH ACCURATE CONTROL OF TRANSCONDUCTANCE
- AUTOMATIC PLAY-BACK/RECORD SWITCHING BY SCANNING OF RECORD SUPPLY
- PLAY-BACK LOOP INHIBITION
- RECORD AMPLIFIER WITH AUTOMATIC PROTECTION AGAINST SHORT CIRCUIT

DESCRIPTION

The TEA5703 is an advanced three head record and play-back amplifier for VCR.

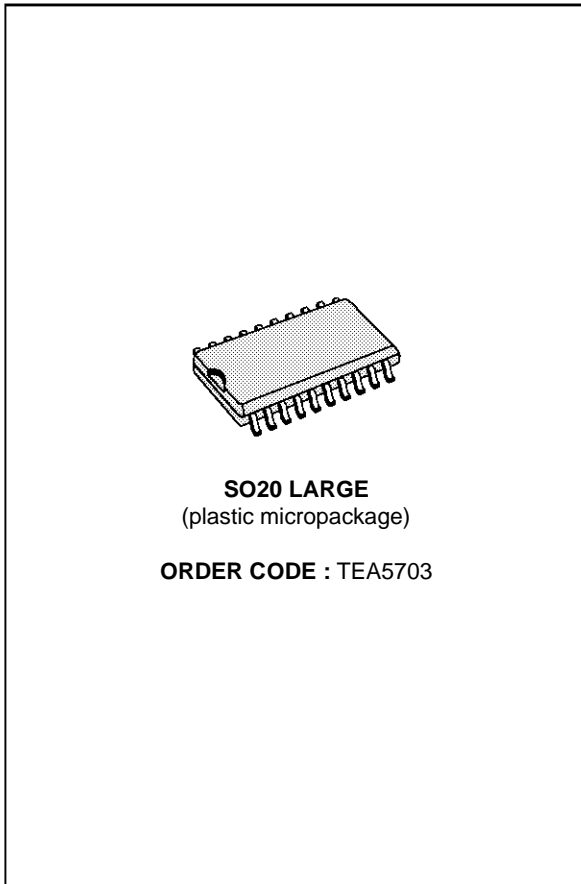

PIN CONNECTIONS

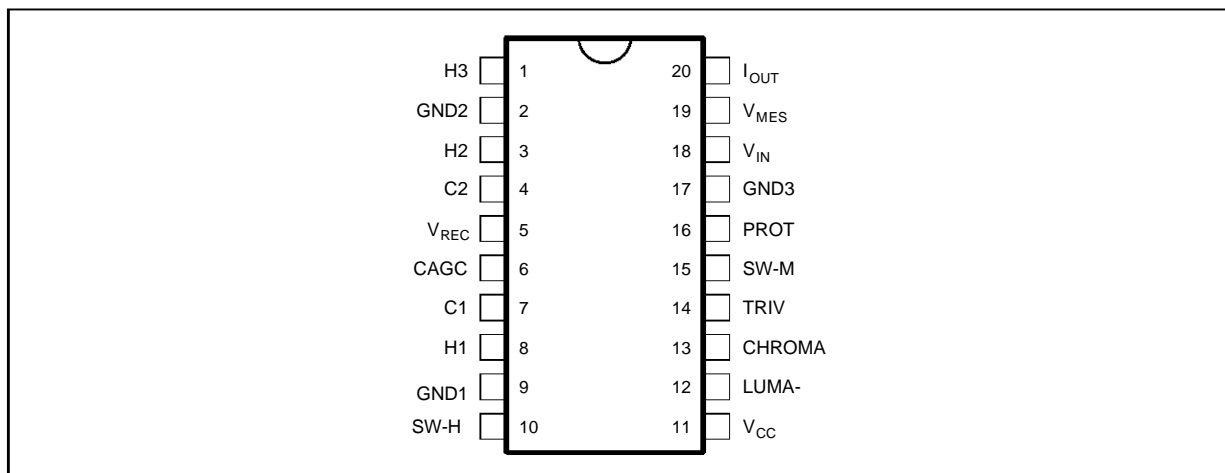

5703-01.EPS

BLOCK DIAGRAM

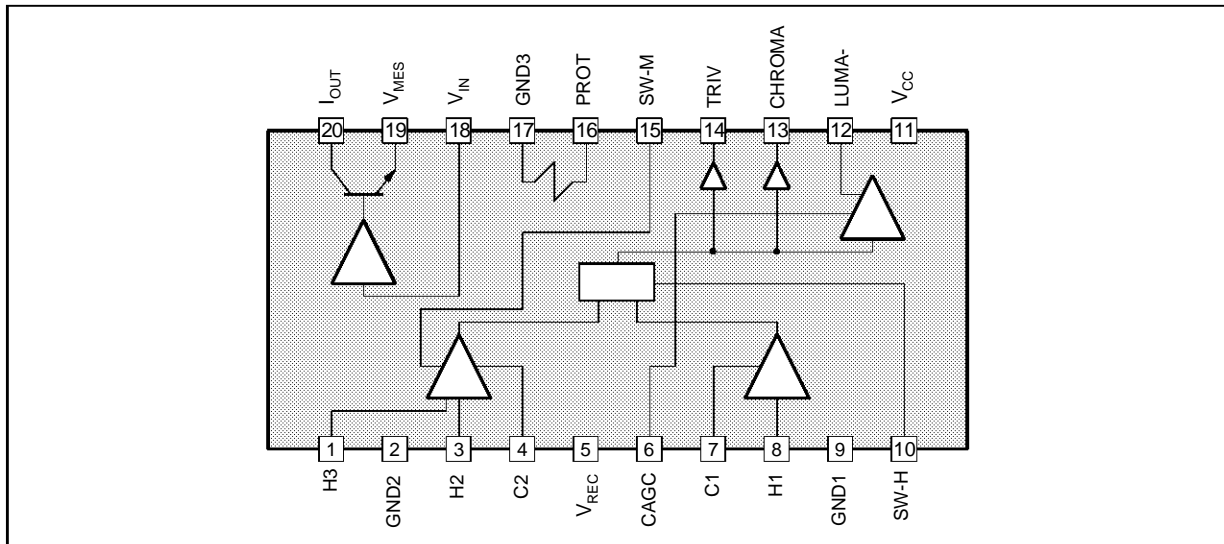

5703-02.EPS

FUNCTIONAL DESCRIPTION

TEA5703 is intended for 3 heads VCR applications. It includes all the electrical functions necessary to achieve play-back and record processing for VHS and S-VHS applications.

High performance technology allows very low noise levels (current and voltage). In play-back mode a special feature suppresses the DC offset when switching two channels. Optimized play-back output stage gives to the TEA5703 large capability to drive directly a coaxial cable in order to reduce number of external components.

Two play-back outputs are available : one, dedicated to Chroma processing, is a 60dB voltage amplifier output, the other one, dedicated to Luma processing, is phase opposite signal with a constant AC output level of 200mV_{PP} at 3.8MHz signal.

A tracking information for video signal (TRIV) is Luma amplitude proportional and allows automatic phase correction.

An automatic scanning of record supply voltage permits TEA5703 automatically switching either in play-back or in record mode. The switching threshold voltage is fixed to a value which forbids high current peaking through the heads.

During play-back mode, record output is grounded via an internal transistor and during record mode preamplifiers are turned off.

There is one output current for the two recording heads, the DC current and the AC characteristics can be very precisely controlled with accurate external resistors. If recommended resistances are used, a ± 5% transconductance accuracy is guaranteed.

Against short circuit on the recording transconductance components, the recording amplifier includes an overheating protection system for the IC and the application board.

TEA5703 is fully protected against ESD.

ABSOLUTE MAXIMUM RATINGS

Symbol	Parameter	Value	Unit
V _{CC}	Power Supply Voltage	6	V
V _{REC}	Power Supply Voltage Record	15	V
T _J	Junction Temperature	150	°C

5703-01.TBL

THERMAL DATA

Symbol	Parameter	Value	Unit
R _{th(j-a)}	Junction-ambient Thermal Resistance	Typ. 70	°C/W

5703-02.TBL

ELECTRICAL OPERATING CHARACTERISTICS ($T_A = 25^\circ\text{C}$ unless otherwise specified)**Power Consumption**

Parameter	Play-Back		Record (1)	
	Typ.	Max.	Typ.	Max.
V_{CC}	45mA	55mA	35mA	45mA
V_{REC}	0mA	0mA	30mA	40mA
Total Consumption	$V_{CC} = 5, V_{REC} = 10$		450mW	
	$V_{CC} = 5.25, V_{REC} = 10.5$		620mW	

5703-03.TBL

Notes : 1. $R1 = 10\Omega$ **Play-back Mode** ($V_{CC} = 5\text{V}$, no load on Pins CHROMA, LUMA-.)

Symbol	Parameter	Test Conditions	Min.	Typ.	Max.	Unit
I_{CC1}	Supply Current		30	45	55	mA
V_{CC}	Supply Voltage		4.75	5	5.25	V

CHROMA OUTPUT (no AGC)

G_{PB}	Pre-amplification Gain	Sinus wave 600 kHz 400mV _{PP} on output Input on Pin H1, H2 or H3	57	60	63	dB
ΔG_{PB}	Gain Difference of Output Signal on Pin CHROMA between Channel 1 and Channel 2	Sinus wave 3.8MHz 0.4mV _{PP} on inputs H1, H2 or H3			1.2	dB
e_N	Equivalent Input Voltage Noise Level	Input grounded via switching transistor on Pins H1, H2, H3		0.45	0.63	nV/ $\sqrt{\text{Hz}}$
i_N	Equivalent Input Current Noise	Pins H1, H2, H3		2.6	3.4	pA/ $\sqrt{\text{Hz}}$
CRT21/31 CRT	Crosstalk	Sinus wave 3.8MHz, 400 μ V _{PP} , H2-H1, H3-H1 All combinations but H2-H1, H3-H1			- 25.5 - 40	dB dB
F_{LCPB} F_{HCPB}	Bandwidth Cut-off Frequency	-3dB attenuation 50 Ω in parallel on the input, 0dB at 600kHz Low High	8		0.1	MHz MHz
C_{IN}	Input Capacitance Pins H1, H2, H3			35	50	pF
R_{IN}	Pre-amplifier Input Resistance Pins H1, H2, H3		350	600	850	Ω
Z_{CPB}	Output Impedance	Sinus wave 0.1MHz 400 μ V _{PP} on input		30	50	Ω
V_{DCPB1}	DC Level at Chroma		1	1.5	2	V
ΔV_{DC}	Head Switch Offset				50	mV
SH_{PB1}	Second Harmonic	Sinus wave 3.8MHz H1, H2, H3 400 μ V _{PP} on input with load resistor 500 Ω		- 45	- 40	dB

LUMA- OUTPUT (with AGC)

Z_{LPB}	Output Impedance	Sinus wave 0.1MHz 400 μ V _{PP} on input		30	50	Ω
V_{DCPB2}	DC Level		1	1.6	2.2	V
V_{LPB}	Output Amplitude	Input signal 200 μ V _{PP} at 3.8MHz on Pins H1, H2, H3	140	200	270	mV _{PP}
ΔV_{LPB}	AGC Control Sensitivity	Input signal 200 μ V _{PP} at +6dB or -5dB on Pins H1, H2, H3	-2		+1	dB
SH_{PB2}	Second Harmonic Play-back Output	Input Signal 3.8MHz 400 μ V _{PP} on Pins H1, H2, H3 500 Ω //100pF		- 43	- 38	dB

5703-04.TBL

ELECTRICAL OPERATING CHARACTERISTICS ($T_A = 25^\circ\text{C}$ unless otherwise specified) (continued)
Play-back Mode ($V_{CC} = 5\text{V}$, no load on Pins CHROMA, LUMA-.)

Symbol	Parameter	Test Conditions	Min.	Typ.	Max.	Unit
I+	Positive Output Current on Pin CAGC	Input Signal 3.8MHz 200 μV_{PP} on H1	15	30	45	μA
I-	Negative Output Current on Pin CAGC	Input Signal 3.8MHz 200 μV_{PP} on H1	-45	-30	-15	μA
	Input Capacitance on Pin CAGC		4.7			nF

LUMA- OUTPUT (with AGC) (continued)

R _{TRIV}	Downloading Resistance		20	40	80	k Ω
V _{TRIV1} V _{TRIV2} V _{TRIV3} V _{TRIV4}	Output Level	V _{CHROMA} = 0mV _{PP} V _{CHROMA} = 100mV _{PP} V _{CHROMA} = 400mV _{PP} V _{CHROMA} = 600mV _{PP}	0.2	0.4 1.6 3.5	4.5	V V V V
G _{TRIV1} G _{TRIV2}	Gain	V _{CHROMA} = 300, 400mV _{PP} V _{CHROMA} = 50, 100mV _{PP}		3 12		V/V _{PP} V/V _{PP}

57/03-05.TBL

Record Mode ($V_{REC} = 10\text{V}$, $V_{CC} = 5\text{V}$, Load resistor 100 Ω on Pin I_{OUT})

Transconductance network defined by :

R1 = 10 Ω 1% Pins PROT/V_{MES}

R2 = 1k Ω 1% Pins V_{MES}/V_{IN}

R3 = 750 Ω 1% Pins V_{IN}

Symbol	Parameter	Test Conditions	Min.	Typ.	Max.	Unit
I _{REC}	Current Supply	V _{REC} = 10V	20	30	40	mA
I _{CC2}		V _{CC} = 5V	25	35	45	mA

I_{OUT}

I _{max}	Max. Record Current	3.8MHz	35			mA _{PP}
TR	Transconductance	V _{IN} = 300mV _{PP}		140		mA/V
SH _{REC}	Second Harmonic	Output Current 30mA _{PP} at 3.8MHz		-40	-38	dB
F _{LCREC} F _{HCRC}	Bandwidth Cut-off Frequency	-3dB attenuation Output current 30mA _{PP} Low High	8		0.1	MHz MHz
	Output Resistance		7	100		k Ω
	Maximum Input Current on Pin PROT	5V on Pin PROT	150	250	400	mA
	Maximum Saturation Voltage on Pin PROT	Input current 50mA		100	150	mV
	Input Resistance	Equivalent value of R3 resistor		700		Ω

57/03-06.TBL

Switching Levels

Symbol	Parameter	Test Conditions	Min.	Typ.	Max.	Unit
V _{SWH1}	Head Selection Pin SW-H	Head number 1	2.4		V _{CC}	V
V _{SWL1}		Head number 2	0		1.5	V
I _{SWHH}		Input Current (high level)		20	50	μA
I _{SWHL}		Output Current (low level)		20	50	μA
V _{SWH2}	Head Selection Pin SW-M	Head number 2 or 1	2.4		V _{CC}	V
V _{SWL2}		Head number 3	0		1.5	V
I _{SWMH}		Input Current (high level)		20	50	μA
I _{SWML}		Output Current (low level)		20	50	μA

57/03-07.TBL

ELECTRICAL OPERATING CHARACTERISTICS ($T_A = 25^\circ\text{C}$ unless otherwise specified) (continued)

Switching Levels

Symbol	Parameter	Test Conditions	Min.	Typ.	Max.	Unit
t_{ON}	Selection Pin SW-H Transient Response	Delay time selection ON (output signal appears on Pin CHROMA)		250	1000	ns
t_{OFF}		Delay time selection OFF (output signal disappears on Pin CHROMA)		250	1000	ns
t_{H2}	Selection Pin SW-M Transient Response	Delay time H2 selection (output signal appears on Pin CHROMA)		1	10	ms
t_{H3}		Delay time H3 selection (output signal appears on Pin CHROMA)		1	10	ms
V_{TH1}	Inhibition Threshold for Switching from Play-back to record on Pin V_{REC}	$V_{CC} = 5V$	0.15	0.3	0.5	V
V_{TH2}	Inhibition Threshold Hysteresis for Switching from Record to Play-back on Pin V_{REC}	$V_{CC} = 5V$		80		mV
t_1	Transient Response of Record Scanning on Pin V_{REC}	Delay from play-back to record (signal disappears on Pin CHROMA)		30		μs
t_2		Delay from record to play-back (signal appears on Pin CHROMA)		20*		ms
t_3		Delay from play-back to record (signal appears on Pin I_{OUT})		0.2		ms
t_4		Delay from record to play-back (signal disappears on Pin I_{OUT})		4*		ms

* Depending on capacitance on Pin V_{REC} .

Power Supply

Symbol	Parameter	Test Conditions	Min.	Typ.	Max.	Unit
V_{CC}	Positive Supply Voltage Pin V_{CC}		4.75	5	5.25	V
V_{REC}	Record Voltage Pin V_{REC}		4.75	10	12.6	V
SVR	Supply Voltage Rejection	0.5mV _{PP} on Pin V_{CC} 75 μ V _{PP} on Pin H1, H2, H3 Measurement on Pin Chroma	15	20		dB

INPUT/OUTPUTS EQUIVALENT INTERNAL DIAGRAM

Pins : C1, C2

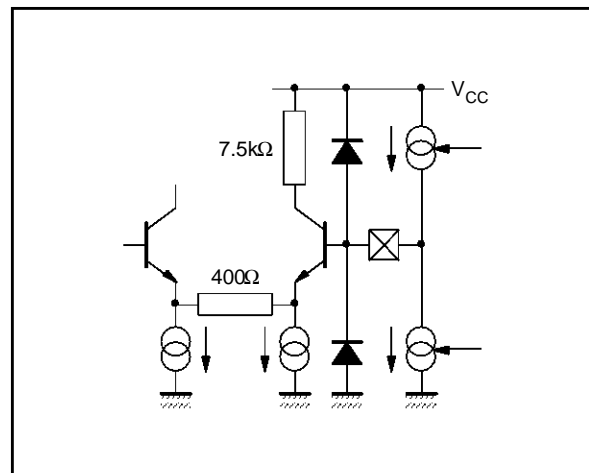

Pin : SW-H, SW-M

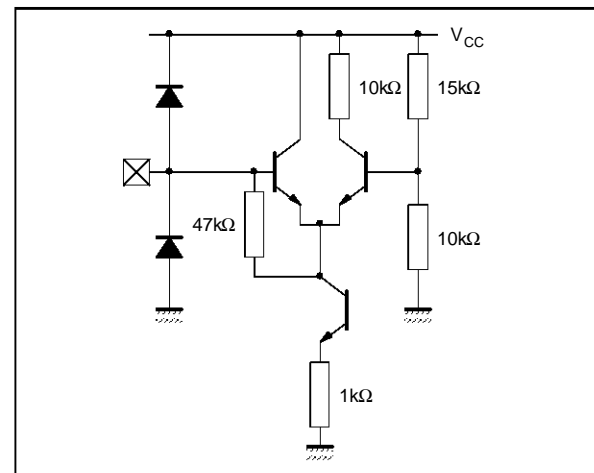

INPUT/OUTPUTS EQUIVALENT INTERNAL DIAGRAM (continued)

Pins : Chroma, Luma-

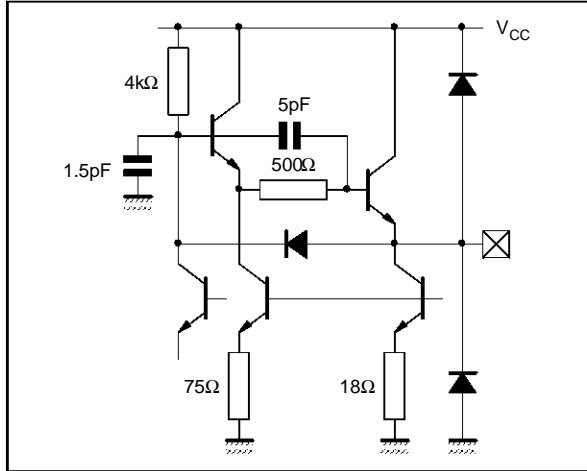

5703-05.EPS

Pin : VMES

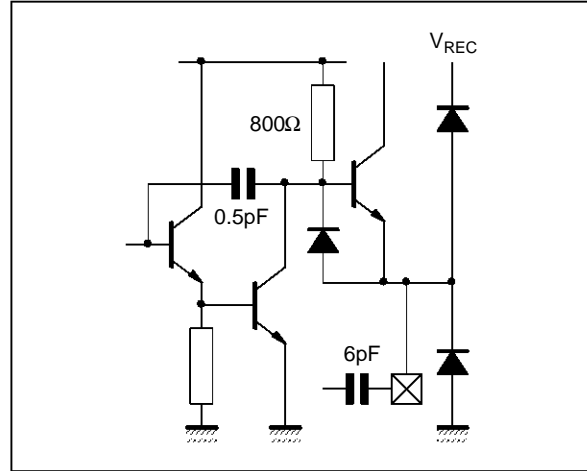

5703-06.EPS

Pin : VIN

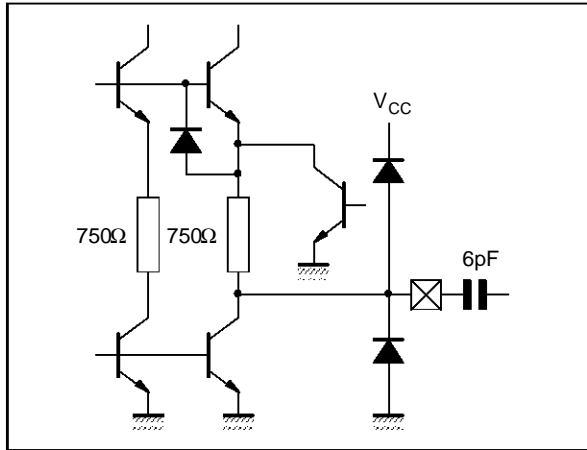

5703-07.EPS

Pin : CAGC

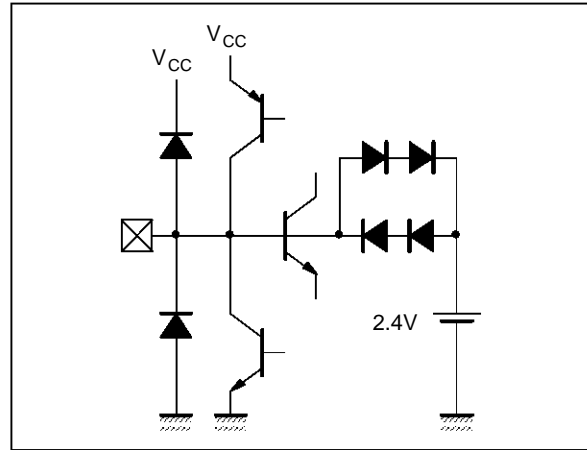

5703-08.EPS

Pin : TRIV

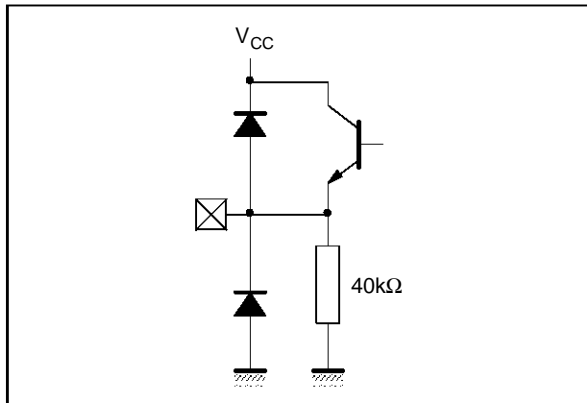

5703-09.EPS

Pin : VCC1

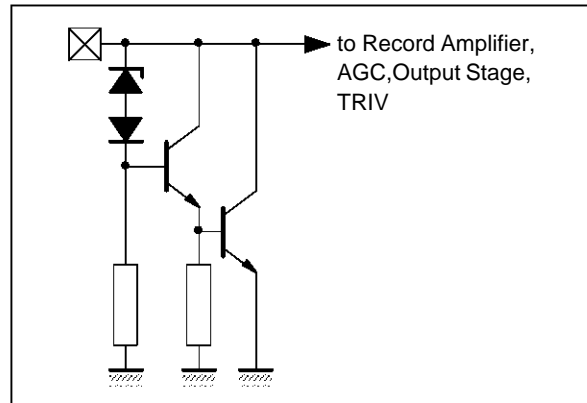

5703-10.EPS

INPUT/OUTPUTS EQUIVALENT INTERNAL DIAGRAM (continued)

Pin : V_{REC}

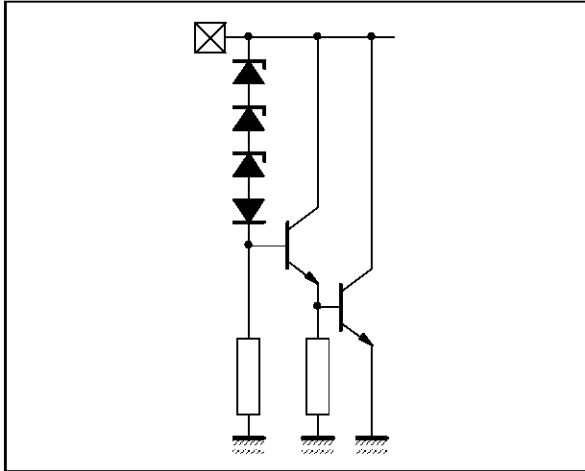

5703-11.EPS

Pin : PROT

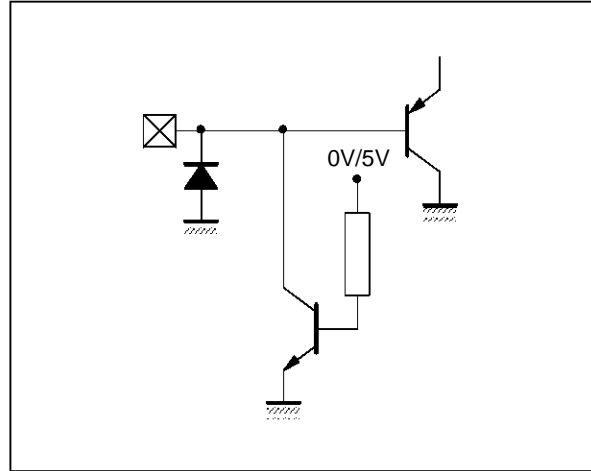

5703-12.EPS

Pin : I_{OUT}

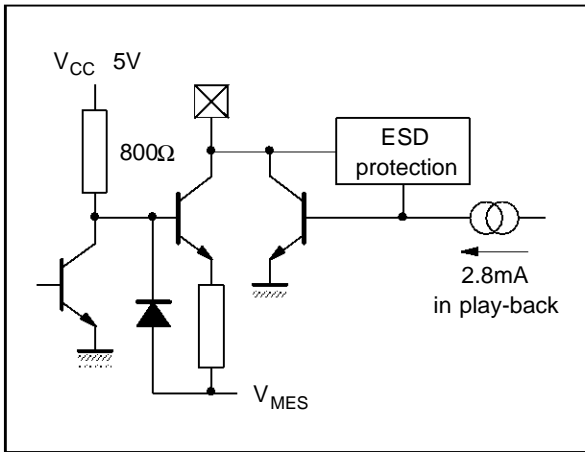

5703-13.EPS

Pins : H1, H2, H3

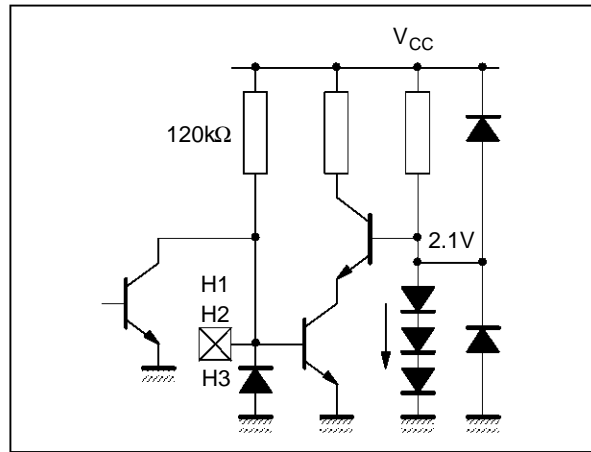

5703-14.EPS

APPLICATION DIAGRAM

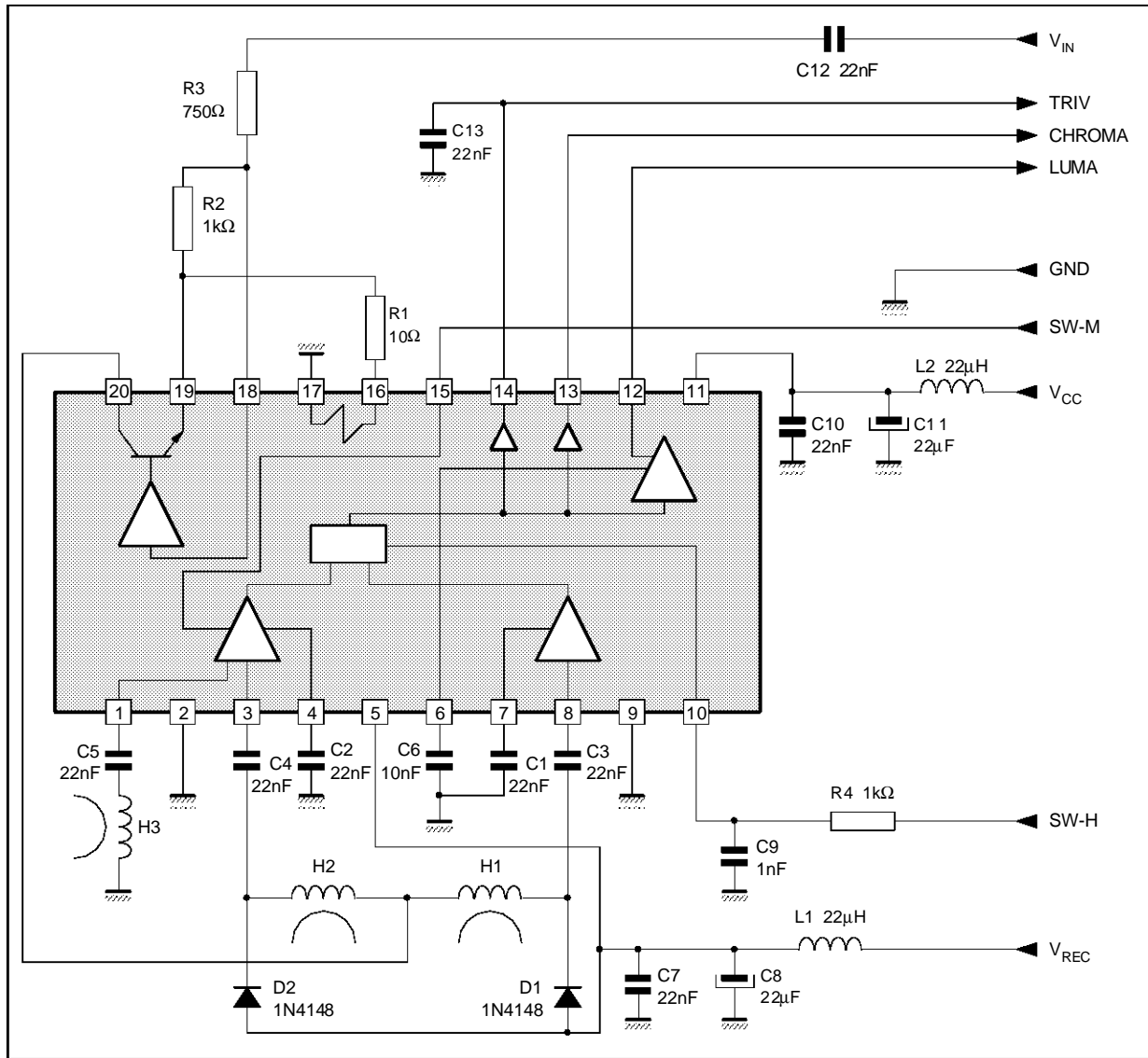

5703-15.EPS

PACKAGE MECHANICAL DATA
20 PINS - PLASTIC MICROPACKAGE

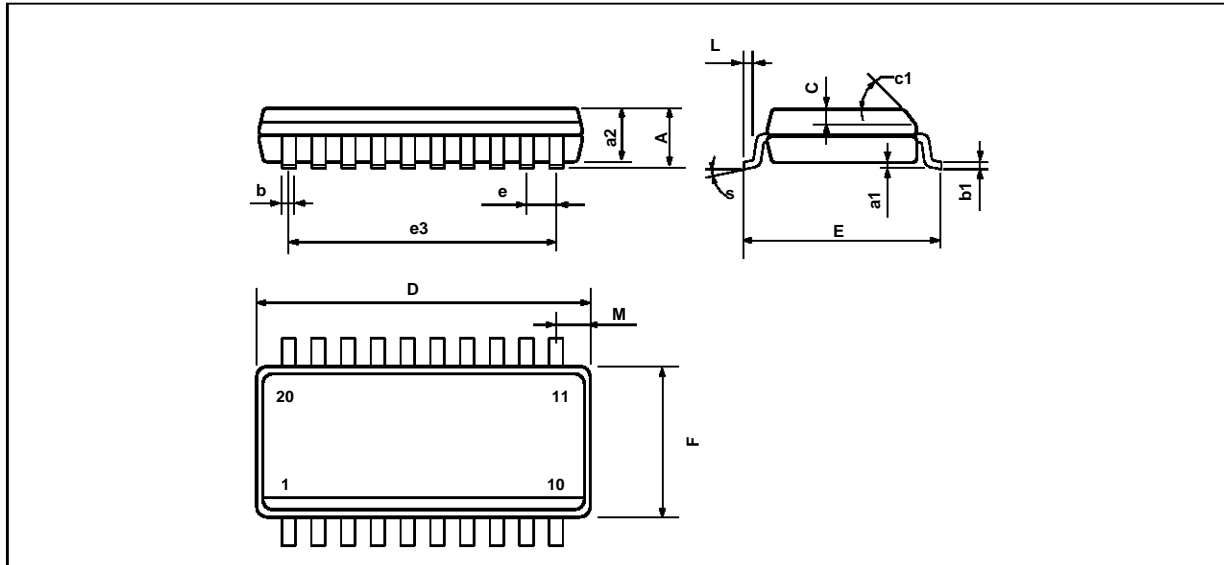

PM-SO20L.EPS

Dimensions	Millimeters			Inches		
	Min.	Typ.	Max.	Min.	Typ.	Max.
A			2.65			0.104
a1	0.1		0.2	0.004		0.008
a2			2.45			0.096
b	0.35		0.49	0.014		0.019
b1	0.23		0.32	0.009		0.013
C		0.5			0.020	
c1	45° (typ.)					
D	12.6		13.0	0.496		0.510
E	10		10.65	0.394		0.419
e		1.27			0.050	
e3		11.43			0.450	
F	7.4		7.6	0.291		0.300
L	0.5		1.27	0.020		0.050
M			0.75			0.030
S	8° (max.)					

SO20L.TBL

Information furnished is believed to be accurate and reliable. However, SGS-THOMSON Microelectronics assumes no responsibility for the consequences of use of such information nor for any infringement of patents or other rights of third parties which may result from its use. No licence is granted by implication or otherwise under any patent or patent rights of SGS-THOMSON Microelectronics. Specifications mentioned in this publication are subject to change without notice. This publication supersedes and replaces all information previously supplied. SGS-THOMSON Microelectronics products are not authorized for use as critical components in life support devices or systems without express written approval of SGS-THOMSON Microelectronics.

© 1994 SGS-THOMSON Microelectronics - All Rights Reserved

Purchase of I²C Components of SGS-THOMSON Microelectronics, conveys a license under the Philips I²C Patent. Rights to use these components in a I²C system, is granted provided that the system conforms to the I²C Standard Specifications as defined by Philips.

SGS-THOMSON Microelectronics GROUP OF COMPANIES

Australia - Brazil - China - France - Germany - Hong Kong - Italy - Japan - Korea - Malaysia - Malta - Morocco
The Netherlands - Singapore - Spain - Sweden - Switzerland - Taiwan - Thailand - United Kingdom - U.S.A.