

**VIDEO CELLULAR MATRIX**

- 6 VIDEO INPUTS - 8 VIDEO OUTPUTS
- 2 INTERNAL SELECTABLE YC ADDERS
- 15MHz BANDWIDTH @ -3dB
- SELECTABLE 0.5/6.5dB GAIN FOR EACH OUTPUT
- HIGH IMPEDANCE SWITCH FOR EACH OUTPUT (3-state operation)
- PROGRAMMABLE CLAMP MODE ON EACH INPUT (sync bottom or average value)
- -60dB CROSSTALK @ 5MHz
- 4 SUB-ADDRESS CAPABILITY
- I<sup>2</sup>C BUS CONTROL

**DESCRIPTION**

This device is intended for switching between video and chroma signals such as CVBS, SVHS, base-band CVBS, MAC. Each input clamp mode, each output gain, all switching are controlled through the I<sup>2</sup>C bus. The 8 outputs can be set separately in high impedance state, to enable parallel DC connection of several devices (up to 4).

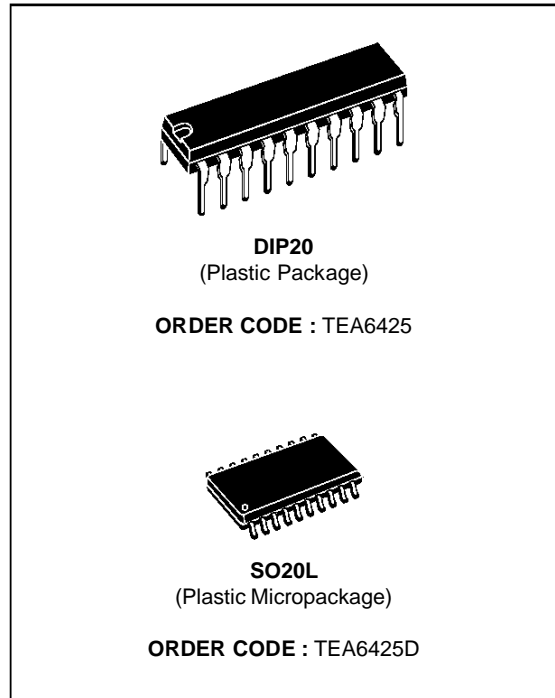

**PIN CONNECTIONS**

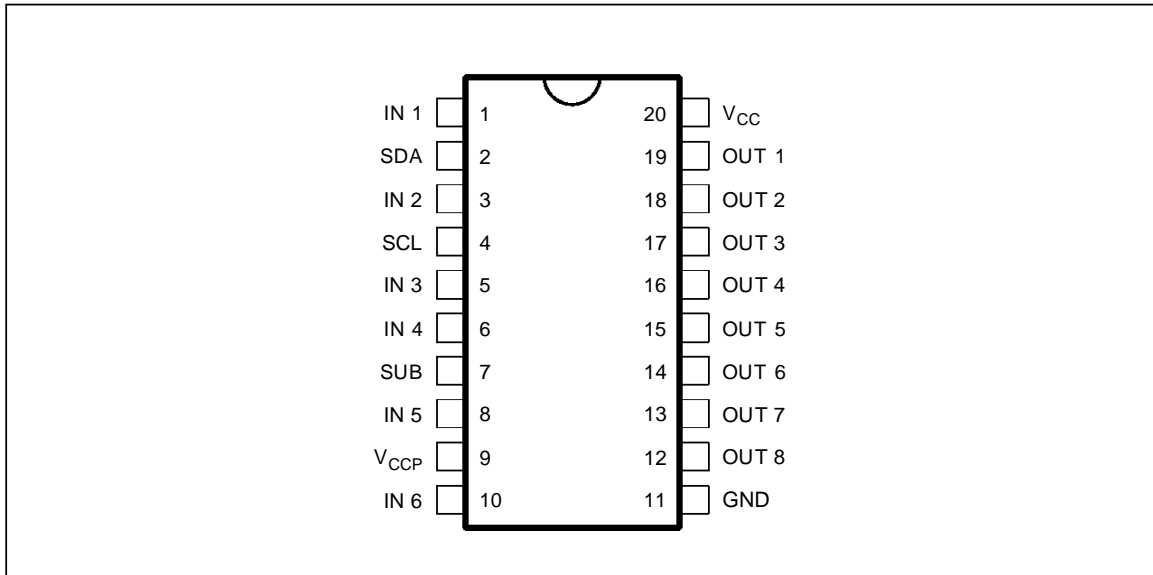

6425-01.EPS

**BLOCK DIAGRAM**

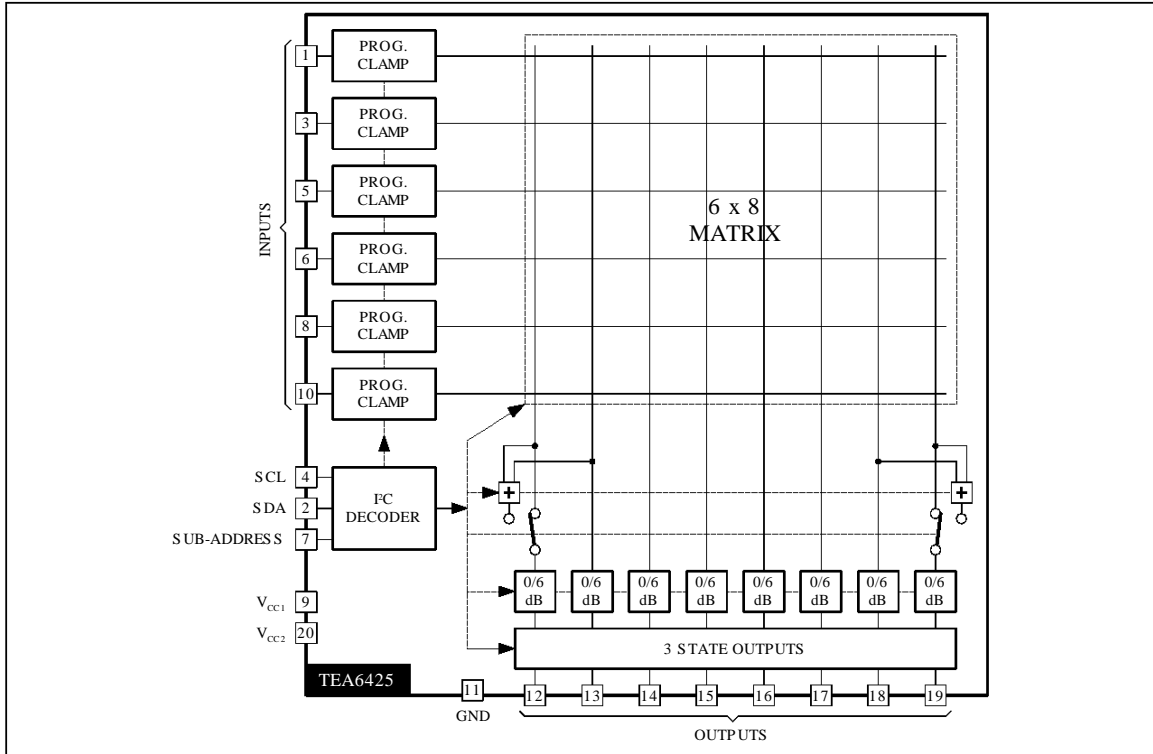

6425-02.EPS

**CELLULAR MATRICE CONNECTIONS**

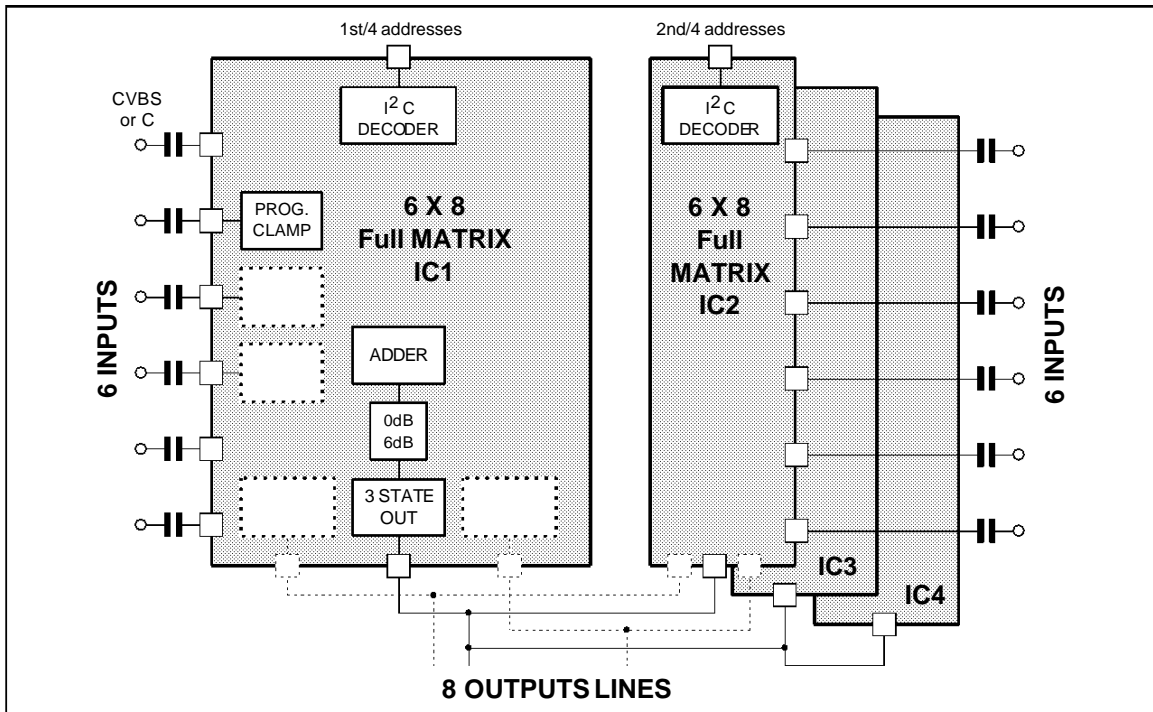

6425-03.EPS

## ABSOLUTE MAXIMUM RATINGS

Symbol	Parameter	Value	Unit
V <sub>CC</sub>	Supply Voltage	12	V
V <sub>I</sub>	Voltage at Pin i to GND	0, V <sub>CC</sub>	V
T <sub>oper</sub>	Operating Ambient Temperature	0, + 70	°C
T <sub>stg</sub>	Storage Temperature	-20, + 150	°C

6425-01.TBL

## THERMAL DATA

Symbol	Parameter	Value	Unit
R <sub>th(j-a)</sub>	Junction-ambient Thermal Resistance	Min. 80	°C/W

6425-02.TBL

**ELECTRICAL CHARACTERISTICS** (V<sub>CC</sub> = 8V, T<sub>amb</sub> = 25°C, V<sub>IN</sub> = 1V, Gain = 6.5dB, C<sub>load</sub> = 20pF, R<sub>load</sub> = 4.7kΩ ; Gain condition, clamp and 3-state are controlled by I<sup>2</sup>C bus, unless otherwise specified)

Symbol	Parameter	Test Conditions	Min.	Typ.	Max.	Unit
SUPPLY						
V <sub>CC</sub>	Supply Voltage		7.2	8	8.8	V
I <sub>CC</sub>	Supply Current			45	60	mA
RR	Supply Voltage Rejection	f = 1kHz	40	46		dB

VIDEO INPUTS (clamping at bottom sync level)

V <sub>IN</sub>	Max. Signal Amplitude	Clamp Active	2			V <sub>PP</sub>
V <sub>clamp</sub>	Clamp Level	Clamp Active	1.7	2	2.3	V
V <sub>DC</sub>	Input DC Level	Clamp Inactive	2.7	3	3.3	V
I <sub>IN</sub>	Leakage Current	1 input connected to 1 output		2	5	μA
I <sub>clamp</sub>	Clamp Current	V <sub>clamp</sub> - 200mV		0.9	3	mA

VIDEO OUTPUTS

R <sub>OUT</sub>	Output Resistance			15	50	Ω
Z <sub>HI</sub>	Output "off" Impedance	no load	50			kΩ
C <sub>HI</sub>	C <sub>OUT</sub> in 3-state	no load		3		pF
G1	Voltage Gain	f = 100kHz	0	0.5	1	dB
G2	Voltage Gain	f = 100kHz	6	6.5	7	dB
V <sub>sync</sub>	Top Level Sync (Y or CVBS)	G = 6.5dB, Clamp Active	1	1.25	2	V
V <sub>bias</sub>	Output Mean Level (chroma)	G = 0.5dB, Clamp Inactive	2	2.4	3	V
		G = 6.5dB, Clamp Inactive	3	3.4	4	V
	Isolation "off" State	f = 5MHz	60			dB
	Crosstalk Attenuation between Channels	f = 5MHz	50	60		dB
B	Bandwidth	C <sub>load</sub> = 20pF, G = 6.5dB at ± 0.5dB at ± 1dB at - 3dB		5		MHz
				10		
				21		

6425-03.TBL

## FUNCTIONAL DESCRIPTION

This device is controlled via the I<sup>2</sup>C bus. 4 addresses can be selected by a 4-level detector on Pin 7, thus enabling parallel connection of 4 devices.

Via the I<sup>2</sup>C bus :

- The input signals can be clamped at their negative peak (top sync).
- The gain factor of the outputs can be selected

between 0.5 and 6.5dB.

- Each of the 6 inputs can be connected to the 8 outputs.
- Each output can individually be set in a high impedance state.

Two internal SVHS mixers will add the selected Y and C inputs. Two dedicated outputs will have the option to select this added signal also.

I<sup>2</sup>C BUS CHARACTERISTICS

Symbol	Parameter	Test Conditions	Standard Mode		Fast Mode		Unit
			Min.	Max.	Min.	Max.	

## SCL

V <sub>IL</sub>	Low Level Input Voltage		- 0.3	+ 1.5	- 0.3	+ 1.5	V
V <sub>IH</sub>	High Level Input Voltage		3.0	V <sub>CC</sub> + 0.5	3.0	V <sub>CC</sub> + 0.5	V
I <sub>LI</sub>	Input Leakage Current	V <sub>I</sub> = 0 to V <sub>DD</sub>	- 10	+ 10	- 10	+ 10	μA
f <sub>SCL</sub>	Clock Frequency		0	100	0	400	kHz
t <sub>R</sub>	Input Rise Time	1.5V to 3V		1000		300	ns
t <sub>F</sub>	Input Fall Time	1.5V to 3V		300		300	ns
C <sub>I</sub>	Input Capacitance			10		10	pF

## SDA

V <sub>IL</sub>	Low Level Input Voltage		- 0.3	+ 1.5	- 0.3	+ 1.5	V
V <sub>IH</sub>	High Level Input Voltage		3.0	V <sub>CC</sub> + 0.5	3.0	V <sub>CC</sub> + 0.5	V
I <sub>LI</sub>	Input Leakage Current	V <sub>I</sub> = 0 to V <sub>DD</sub>	- 10	+ 10	- 10	+ 10	μA
C <sub>I</sub>	Input Capacitance			10		10	pF
t <sub>R</sub>	Input Rise Time	1.5V to 3V		1000		300	ns
t <sub>F</sub>	Input Fall Time	1.5V to 3V		300		300	ns
V <sub>OL</sub>	Low Level Output Voltage	I <sub>OL</sub> = 3mA		0.4		0.4	V
t <sub>F</sub>	Output Fall Time	3V to 1.5V		250		250	ns
C <sub>L</sub>	Load Capacitance			400		400	pF

## TIMING

t <sub>LOW</sub>	Clock Low Period		4.7		1.3		μs
t <sub>HIGH</sub>	Clock High Period		4.0		0.6		μs
t <sub>SU, DAT</sub>	Data Set-up Time		250		100		ns
t <sub>HD, DAT</sub>	Data Hold Time		0	340	0	340	ns
t <sub>SU, STO</sub>	Set-up Time from Clock High to Stop		4.0		0.6		μs
t <sub>BUF</sub>	Start Set-up Time following a Stop		4.7		1.3		μs
t <sub>HD, STA</sub>	Start Hold Time		4.0		0.6		μs
t <sub>SU, STA</sub>	Start Set-up Time following Clock Low-to High Transition		4.7		0.6		μs

6425-04.TBL

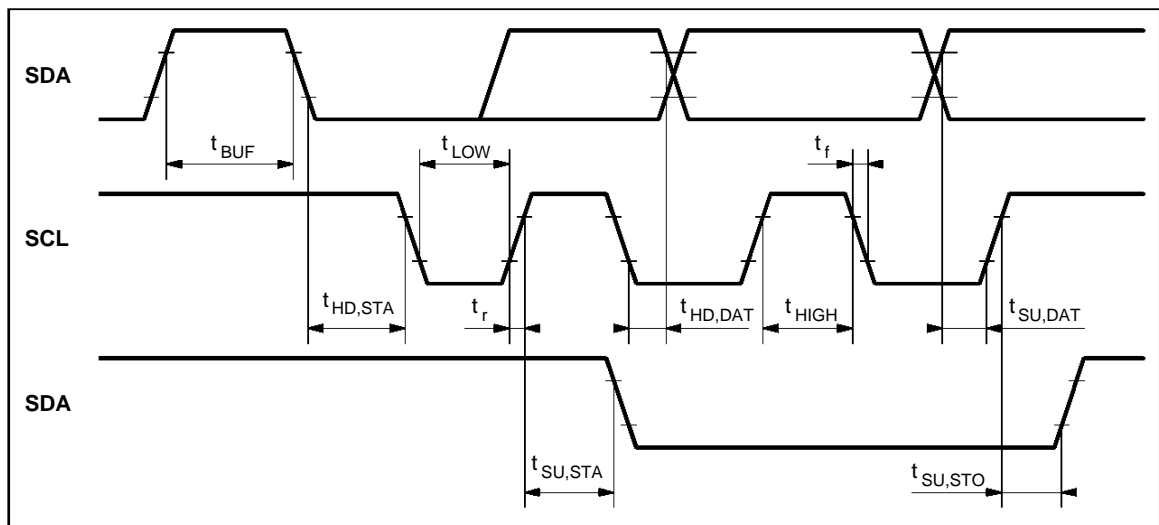
Figure 1 : I<sup>2</sup>C Bus Timing

6425-04.EPS

## I<sup>2</sup>C BUS SELECTION

### I<sup>2</sup>C Bus Slave Address

Address	A6	A5	A4	A3	A2	A1	A0	R/W
Value	1	0	0	1	0	A1	A0	0

### Sub-address I<sup>2</sup>C

Symbol	Parameter	Conditions	Pin 7 Voltage (typ.)	Unit
Vsub	Slave address HEXA	Sub-address (see note)		
1	90	A1 A0 0 0	GND	V
2	96	1 1	V <sub>CC</sub>	V
3	94	1 0	1/3	V <sub>CC</sub>
4	92	0 1	2/3	V <sub>CC</sub>

**Note :** The first 3 levels are defined by connecting the sub-address pin to the appropriate level. Sub-address 4 will be selected when this pin is left open.

### 1st Data Byte

	b7	b6	b5	b4	b3	b2	b1	b0	Selected Output
	a2	a1	a0	*	*	*	*	I	
Output Select	0	0	0	*	*	*	*	0	OUT1
	0	0	1	*	*	*	*	0	OUT2
	0	1	0	*	*	*	*	0	OUT3
	0	1	1	*	*	*	*	0	OUT4
	1	0	0	*	*	*	*	0	OUT5
	1	0	1	*	*	*	*	0	OUT6
	1	1	0	*	*	*	*	0	OUT7
	1	1	1	*	*	*	*	0	OUT8

### 2nd Data Byte

	b7	b6	b5	b4	b3	b2	b1	b0	Action
	a2	a1	a0	*	*	*	*	I	
Input Select	0	0	0	*	*	*	*	1	IN1
	0	0	1	*	*	*	*	1	IN2
	0	1	0	*	*	*	*	1	IN3
	0	1	1	*	*	*	*	1	IN4
	1	0	0	*	*	*	*	1	IN5
	1	0	1	*	*	*	*	1	IN6
Clamp	*	*	*	0	*	*	*	1	Free
	*	*	*	1	*	*	*	1	Clamped
Gain	*	*	*	*	0	*	*	1	0.5dB
	*	*	*	*	1	*	*	1	6.5dB
Mixer	*	*	*	*	*	0	*	1	Disabled
	*	*	*	*	*	1	*	1	Enabled
Tri-state	*	*	*	*	*	*	0	1	Low impedance
	*	*	*	*	*	*	1	1	Tri-state

### Power On Reset

When active : outputs in 3-state, inputs are clamped.

Symbol	Parameter	Conditions	Min.	Typ.	Max.	Unit
Reset	Start of Reset	Incr. V <sub>CC</sub>			2.5	V
	End of Reset	Decr. V <sub>CC</sub> Incr. V <sub>CC</sub>	4.5		4.2	V

**PIN CONFIGURATIONS**

**Figure 2 : Video IN**

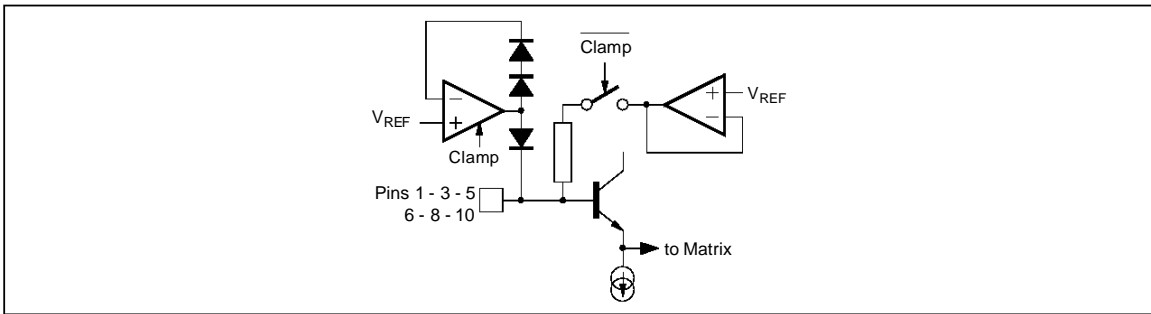

6425-06.EPS

**Figure 3 : Video OUT**

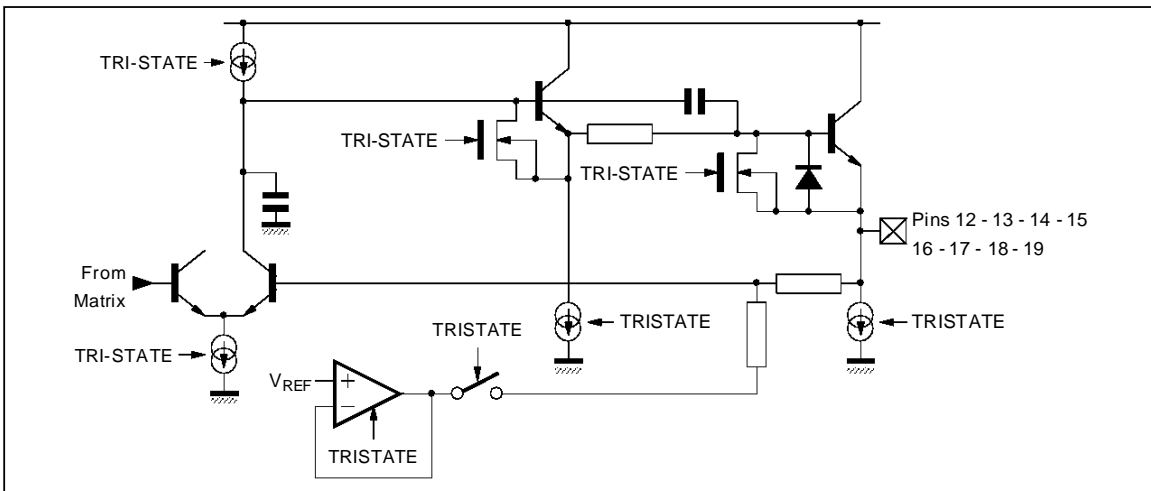

6425-06.EPS

**Figure 4 : PROG Pin**

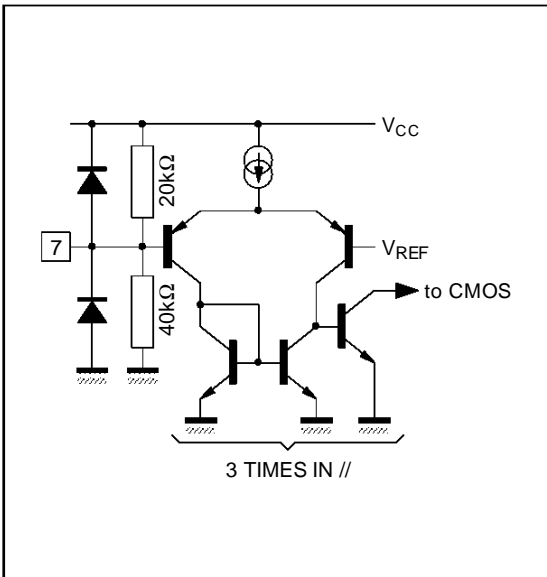

6425-07.EPS

**Figure 5 : Bus Inputs**

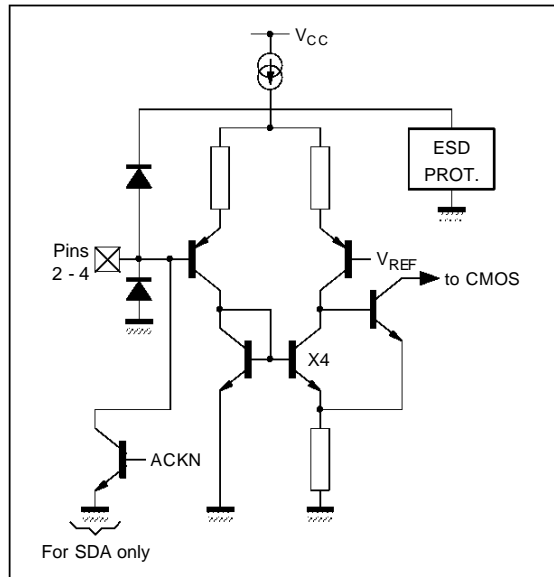

6425-08.EPS

TYPICAL APPLICATION

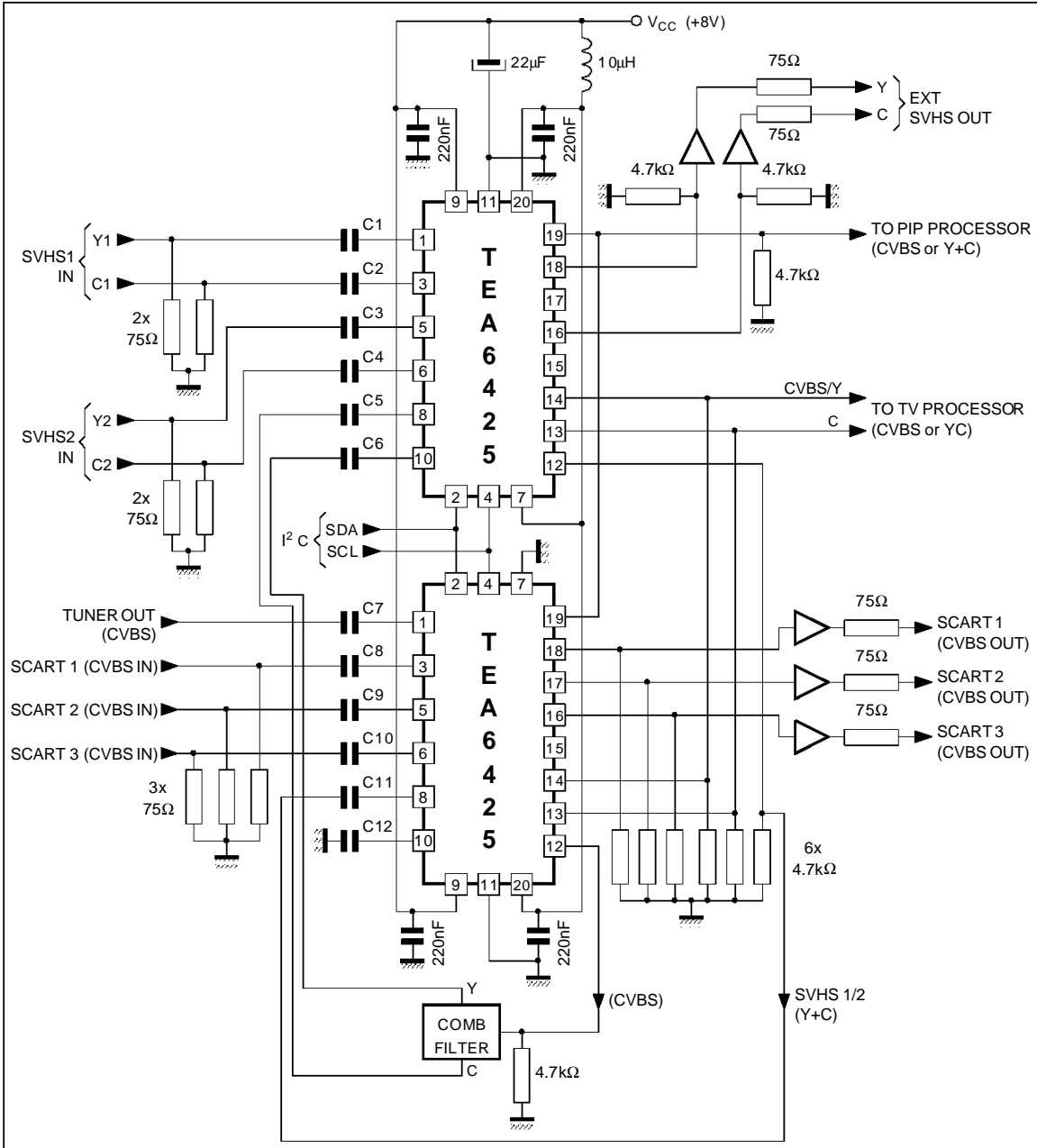

6425-09.EPS

**PACKAGE MECHANICAL DATA**  
20 PINS - PLASTIC DIP

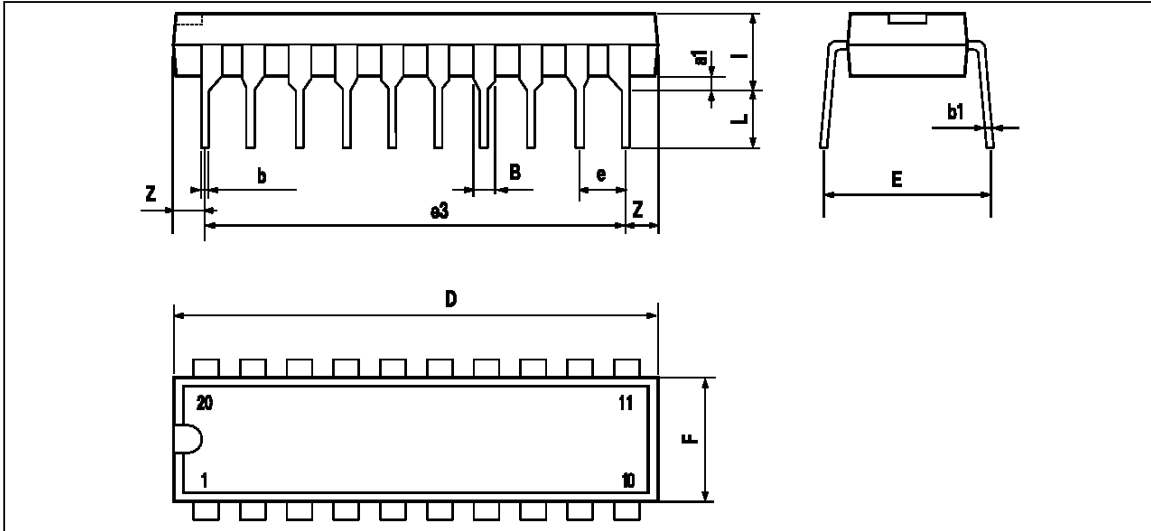

PM-DIP20.EPS

Dimensions	Millimeters			Inches		
	Min.	Typ.	Max.	Min.	Typ.	Max.
a1	0.254			0.010		
B	1.39		1.65	0.055		0.065
b		0.45			0.018	
b1		0.25			0.010	
D			25.4			1.000
E		8.5			0.335	
e		2.54			0.100	
e3		22.86			0.900	
F			7.1			0.280
I			3.93			0.155
L		3.3			0.130	
Z			1.34			0.053

DIP20.TBL

**PACKAGE MECHANICAL DATA**  
20 PINS - PLASTIC MICROPACKAGE

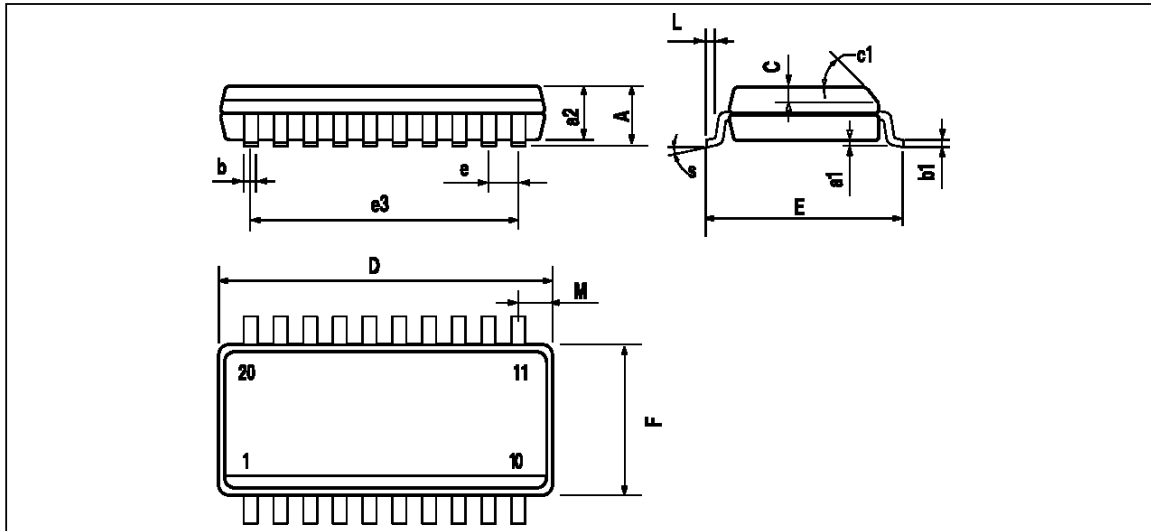

PM-SO20.EPS

Dimensions	Millimeters			Inches		
	Min.	Typ.	Max.	Min.	Typ.	Max.
A			2.65			0.104
a1	0.1		0.3	0.004		0.012
a2			2.45			0.096
b	0.35		0.49	0.014		0.019
b1	0.23		0.32	0.009		0.013
C		0.5			0.020	
c1	45° (typ.)					
D	12.6		13.0	0.496		0.512
E	10		10.65	0.394		0.419
e		1.27			0.050	
e3		11.43			0.450	
F	7.4		7.6	0.291		0.299
L	0.5		1.27	0.020		0.050
M			0.75			0.030
S	8° (Max.)					

SO20.TBL

Information furnished is believed to be accurate and reliable. However, SGS-THOMSON Microelectronics assumes no responsibility for the consequences of use of such information nor for any infringement of patents or other rights of third parties which may result from its use. No licence is granted by implication or otherwise under any patent or patent rights of SGS-THOMSON Microelectronics. Specifications mentioned in this publication are subject to change without notice. This publication supersedes and replaces all information previously supplied. SGS-THOMSON Microelectronics products are not authorized for use as critical components in life support devices or systems without express written approval of SGS-THOMSON Microelectronics.

© 1996 SGS-THOMSON Microelectronics - All Rights Reserved

Purchase of  $\mu$ C Components of SGS-THOMSON Microelectronics, conveys a license under the Philips  $\mu$ C Patent. Rights to use these components in a  $\mu$ C system, is granted provided that the system conforms to the  $\mu$ C Standard Specifications as defined by Philips.

SGS-THOMSON Microelectronics GROUP OF COMPANIES

Australia - Brazil - Canada - China - France - Germany - Hong Kong - Italy - Japan - Korea - Malaysia - Malta - Morocco  
The Netherlands - Singapore - Spain - Sweden - Switzerland - Taiwan - Thailand - United Kingdom - U.S.A.