

AUDIO CELLULAR MATRIX

- 5 STEREO INPUTS - 4 STEREO OUTPUTS
- 3-STATE OPERATION FOR EACH OUTPUT
- GAIN OUTPUT CONTROL
0dB/2/4/6dB/MUTE FOR EACH
- VERY LOW NOISE AND DISTORTION
- I²C BUS CONTROL
- 4 SUB-ADDRESS FACILITY
- 90dB CROSSTALK BETWEEN ANY INPUT AND OUTPUT

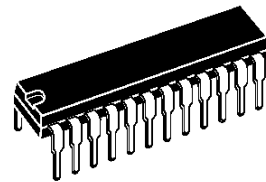

SHRINK 24
(Plastic Package)

ORDER CODE : TEA6430

DESCRIPTION

The TEA6430 switches 5 stereo inputs on 4 stereo outputs, providing the customer with high quality sound (low noise, low distortion). The 4 stereo outputs can be set separately in high impedance state, to enable parallel connection of several devices (up to 4). All functions are controlled through the I²C bus.

PIN CONNECTIONS

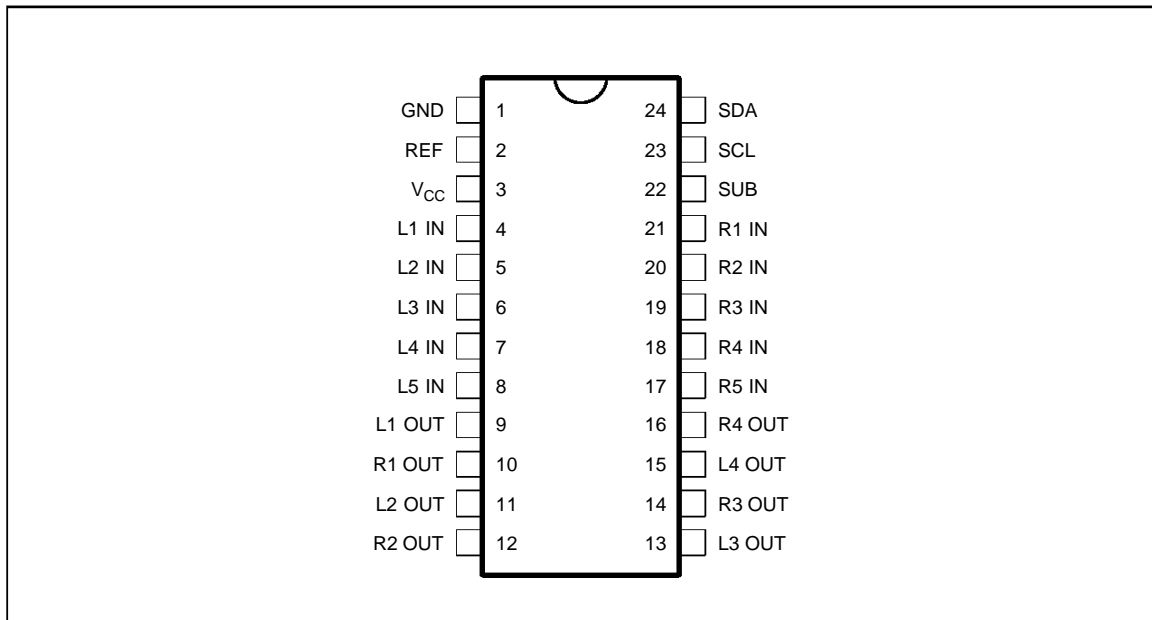

6430-01.EPS

BLOCK DIAGRAM

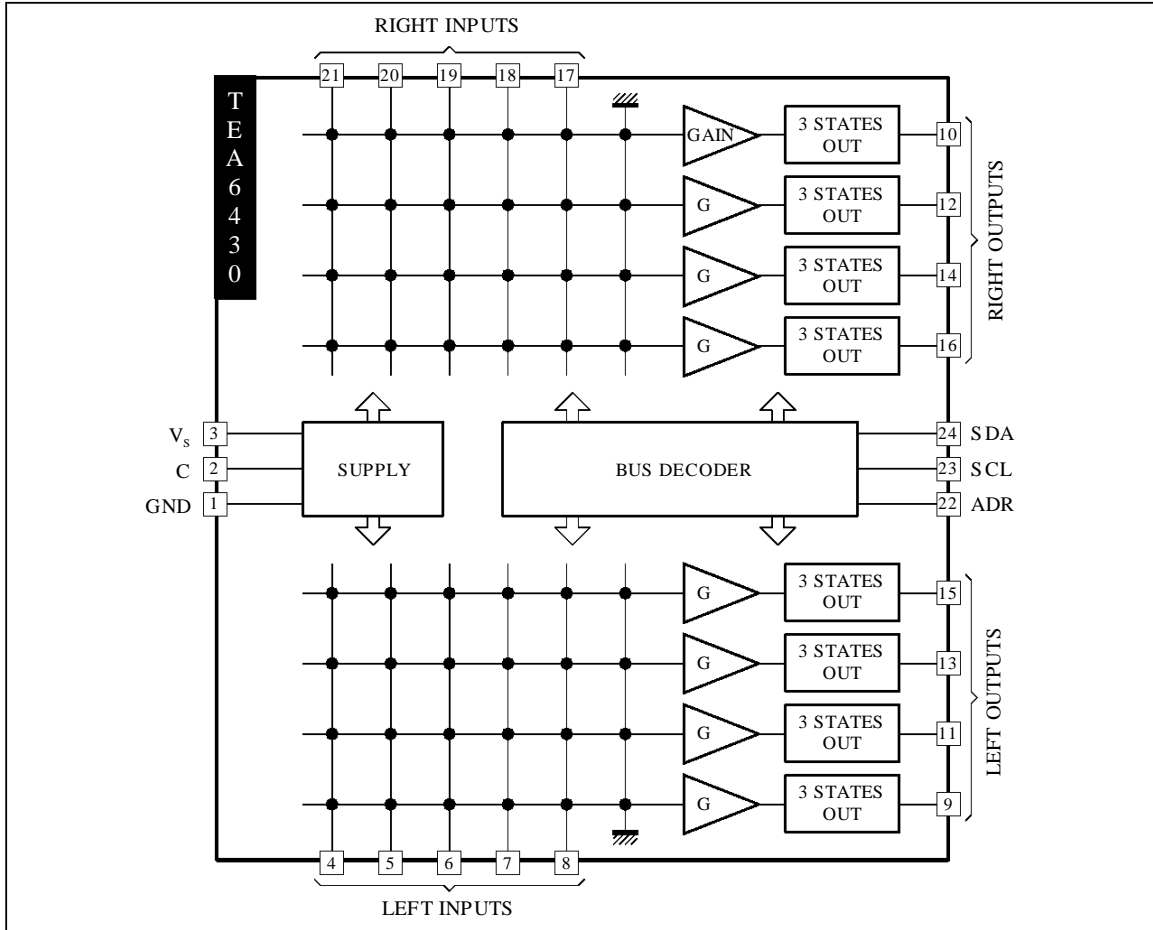

The output loads have to be larger than 2kΩ (typical 10kΩ) and 1500pF

ABSOLUTE MAXIMUM RATINGS

Symbol	Parameter	Value	Unit
V _{CC}	Supply Voltage	12	V
V _I	Voltage at Pin i to GND	0, V _{CC}	V
T _{oper}	Operating Ambient Temperature	0, + 70	°C
T _{stg}	Storage Temperature	-20, + 150	°C

THERMAL DATA

Symbol	Parameter	Value	Unit
R _{th(j-a)}	Junction-ambient Thermal Resistance	75	°C/W

ELECTRICAL CHARACTERISTICS

($V_{CC} = 8V$, $T_{amb} = 25^{\circ}C$, $R_L = 10k\Omega$, $R_G = 600\Omega$, $f = 1kHz$, $G = 0dB$, $V_{IN} = 0.5V_{RMS}$;
3-state is controlled by I²C bus, unless otherwise specified)

Symbol	Parameter	Test Conditions	Min.	Typ.	Max.	Unit
--------	-----------	-----------------	------	------	------	------

SUPPLY

V_{CC}	Supply Voltage		7.2	8	10.2	V
I_{CC}	Supply Current		4	7	10	mA
RR	Ripple Rejection	$V_{IN} = 0.5V_{RMS}$, $f = 1kHz$	70			dB

AUDIO INPUTS

V_{IN}	Max. Signal Amplitude		2			V_{RMS}
V_{DC}	Input DC Level			$V_{CC}/2$		V
R_I	Input Resistance		30	50	100	$k\Omega$

AUDIO OUTPUTS

R_{OUT}	Output Resistance			60	100	Ω
Z_{HI}	Output "off" Impedance	$f = 20kHz$, output disabled	50			$k\Omega$
V_{OFF}	DC Offset Change	Switching between inputs, see note 1		0.1	5	mV
V_{OUT}	Output DC Level		$0.4 V_{CC}$	$V_{CC}/2$	$0.6 V_{CC}$	V
V_N	Output Noise Voltage	$B = 20-20kHz$, flat, see note 2		2.5		μV
G	Gain	$B = 20-20kHz$, $R_L = 2k\Omega$	-0.5	0	+0.5	dB
	Isolation "off" State	$f = 1kHz$, output disabled	85			dB
THD	Distortion	$V_{IN} = 1V_{RMS}$, $f = 1kHz$		0.01	0.05	%
V_{CL}	Clipping Level	$d = 0.3\%$	2	2.3		V_{RMS}
C_S	L, R Channel Separation	$f = 1kHz$	-85			dB
	Crosstalk Audio Channels	$f = 1kHz$, see note 3	-85	-100		dB
C_L	Load Capacitance		1500			pF

- Notes :
- DC offset change is less than maximum limit, in all configurations (one or several devices in parallel), provided that the reference Pins (P2) are all connected together.
 - Flat filter according to CCIR-468-4, $B = 20Hz-20kHz$
 - Measured from any selected output which contains no signal to a set of other outputs.

6430-103.TBL

I²C BUS CHARACTERISTICS

Symbol	Parameter	Test Conditions	Standard Mode		Fast Mode		Unit
			Min.	Max.	Min.	Max.	

SCL

V _{IL}	Low Level Input Voltage		- 0.3	+ 1.5	- 0.3	+ 1.5	V
V _{IH}	High Level Input Voltage		3.0	V _{CC} + 0.5	3.0	V _{CC} + 0.5	V
I _{LI}	Input Leakage Current	V _I = 0 to V _{DD}	- 10	+ 10	- 10	+ 10	μA
f _{SCL}	Clock Frequency		0	100	0	400	kHz
t _R	Input Rise Time	1.5V to 3V		1000		300	ns
t _F	Input Fall Time	1.5V to 3V		300		300	ns
C _I	Input Capacitance			10		10	pF

SDA

V _{IL}	Low Level Input Voltage		- 0.3	+ 1.5	- 0.3	+ 1.5	V
V _{IH}	High Level Input Voltage		3.0	V _{CC} + 0.5	3.0	V _{CC} + 0.5	V
I _{LI}	Input Leakage Current	V _I = 0 to V _{DD}	- 10	+ 10	- 10	+ 10	μA
C _I	Input Capacitance			10		10	pF
t _R	Input Rise Time	1.5V to 3V		1000		300	ns
t _F	Input Fall Time	1.5V to 3V		300		300	ns
V _{OL}	Low Level Output Voltage	I _{OL} = 3mA		0.4		0.4	V
t _F	Output Fall Time	3V to 1.5V		250		250	ns
C _L	Load Capacitance			400		400	pF

TIMING

t _{LOW}	Clock Low Period		4.7		1.3		ms
t _{HIGH}	Clock High Period		4.0		0.6		ms
t _{SU,DAT}	Data Set-up Time		250		100		ns
t _{HD,DAT}	Data Hold Time		0	340	0	340	ns
t _{SU,STO}	Set-up Time from Clock High to Stop		4.0		0.6		μs
t _{BUF}	Start Set-up Time following a Stop		4.7		1.3		μs
t _{HD,STA}	Start Hold Time		4.0		0.6		μs
t _{SU,STA}	Start Set-up Time following Clock Low-to High Transition		4.7		0.6		μs

6430-04.TBL

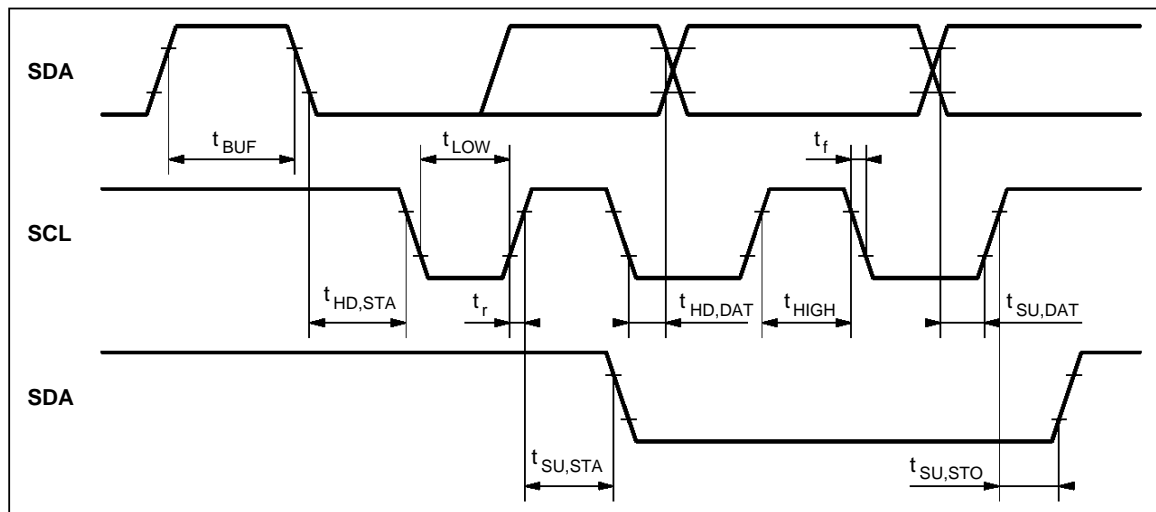
Figure 1 : I²C Bus Timing

6430-03.EPS

I²C BUS SELECTION

I²C Bus Slave Address

Address	A6	A5	A4	A3	A2	A1	A0	R/W
Value	1	0	0	1	1	A1	A0	0

Sub-address I²C

Symbol	Parameter	Conditions	Pin 22 Voltage (typ.)	Unit
Vsub	Slave address HEXA	Sub-address (see note)		
1	98	A1 0 A0 0	GND	V
2	9E	1 1	V _{CC}	V
3	9C	1 0	1/3	V _{CC}
4	9A	0 1	2/3	V _{CC}

Note : The first3 levels are defined by connecting the sub-address pin to the appropriate level. Sub-address 4 will be selected when this pin is left open.

Data Byte

	b7	b6	b5	b4	b3	b2	b1	b0	Action
	T	01	00	G1	G0	I2	I1	I0	
Input Select	*	*	*	*	*	0	0	0	IN1
	*	*	*	*	*	0	0	1	IN2
	*	*	*	*	*	0	1	0	IN3
	*	*	*	*	*	0	1	1	IN4
	*	*	*	*	*	1	0	0	IN5
	*	*	*	*	*	1	0	1	Mute
Output Select	*	0	0	*	*	*	*	*	OUT1
	*	0	1	*	*	*	*	*	OUT2
	*	1	0	*	*	*	*	*	OUT3
	*	1	1	*	*	*	*	*	OUT4
Gain	*	*	*	0	0	*	*	*	6dB
	*	*	*	0	1	*	*	*	4dB
	*	*	*	1	0	*	*	*	2dB
	*	*	*	1	1	*	*	*	0dB
Tri-state	0	*	*	*	*	*	*	*	Low impedance Tri-state
	1	*	*	*	*	*	*	*	

Example : 00111100 enables L(R)2 out and connect it with a gain of 0dB to L(R)5 in.

Power On Reset

When active : outputs in 3-state. All outputs are disabled and L(R)5 is selected to drive all outputs. Gain = 0dB.

Symbol	Parameter	Conditions	Min.	Typ.	Max.	Unit
Reset	Start of Reset	Incr. V _{CC}			2.5	V
		Decr. V _{CC}			4.2	V
	End of Reset	Incr. V _{CC}	4.5			V

TYPICAL PERFORMANCES

Figure 1 : Supply Current as a Function of Supply Voltage

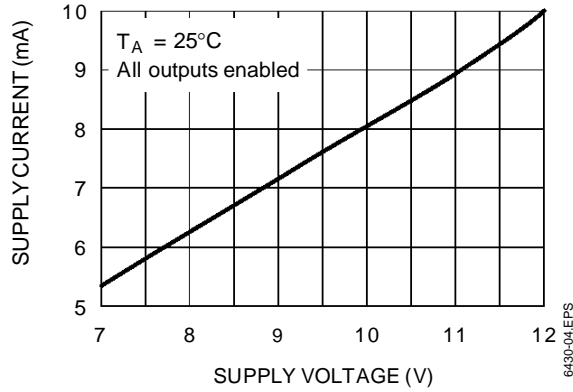

Figure 2 : Supply Current as a Function of Temperature

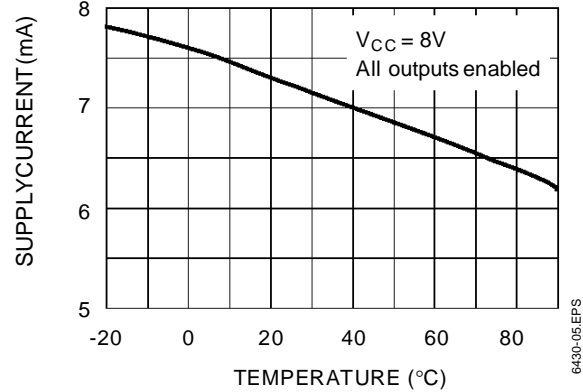

Figure 3 : Ripple Rejection as a Function of Supply Voltage

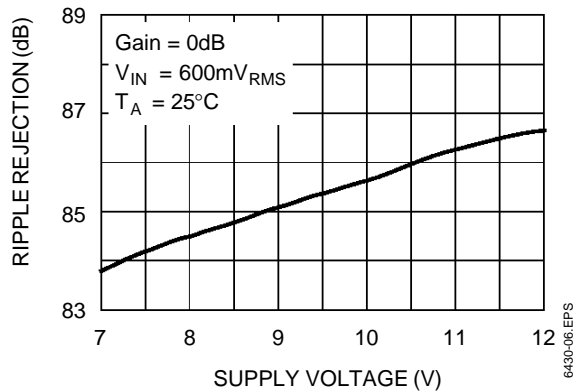

Figure 4 : Ripple Rejection as a Function of Temperature

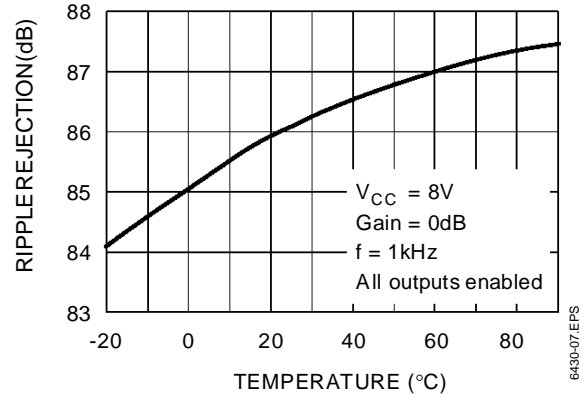

Figure 5 : Ripple Rejection as a Function of Gain

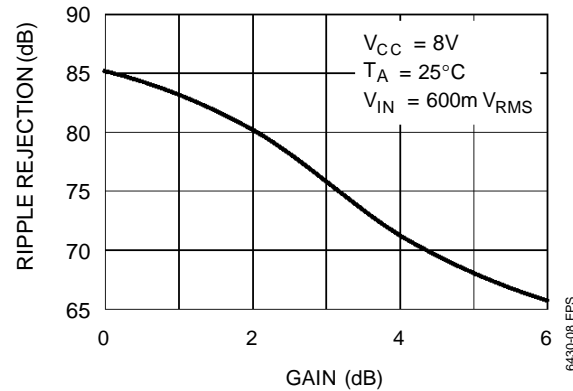
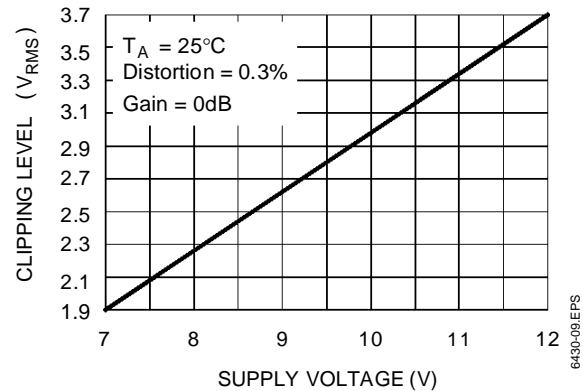
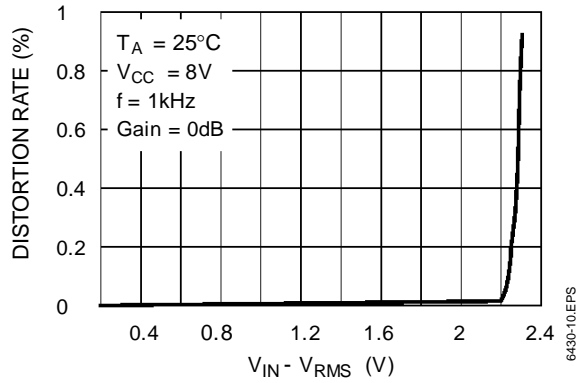
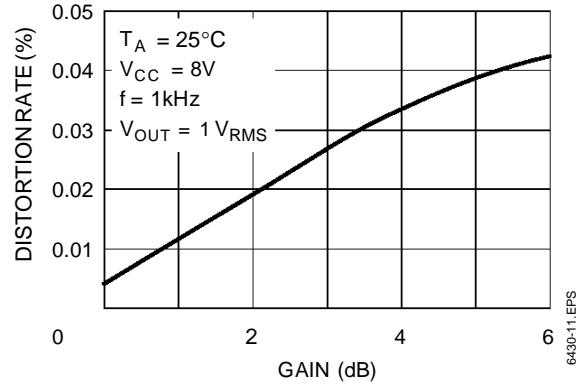
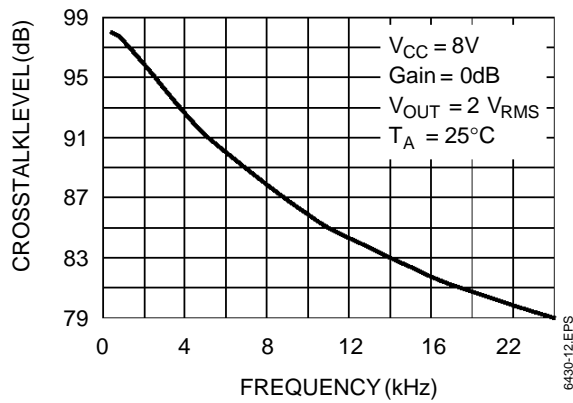
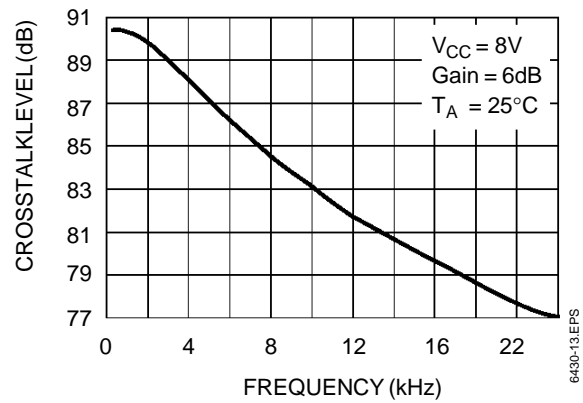

Figure 6 : Clipping Level as a Function of Supply Voltage



TYPICAL PERFORMANCES (continued)

Figure 7 : Distortion as a Function of Input Level**Figure 8 :** Distortion as a Function of Gain**Figure 9 :** Crosstalk Level as a Function of Frequency (Gain = 0dB)**Figure 10 :** Crosstalk Level as a Function of Frequency (Gain = 6dB)

PIN CONFIGURATIONS

Figure 11 : Audio IN

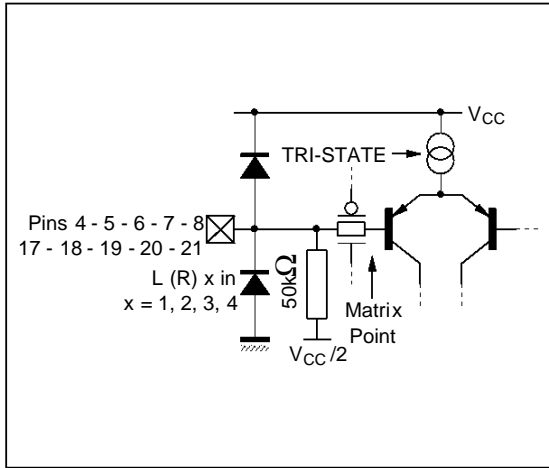

Figure 12 : Audio OUT

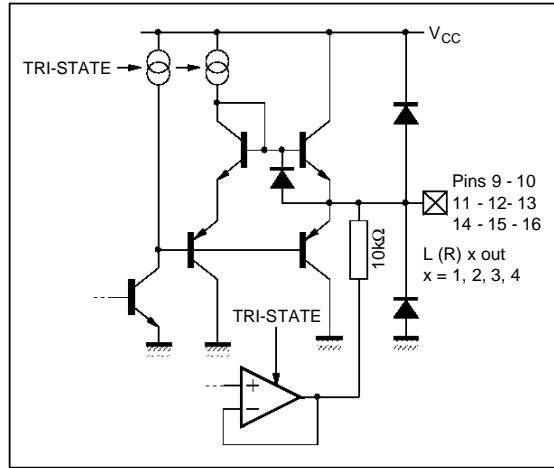

Figure 13 : PROG

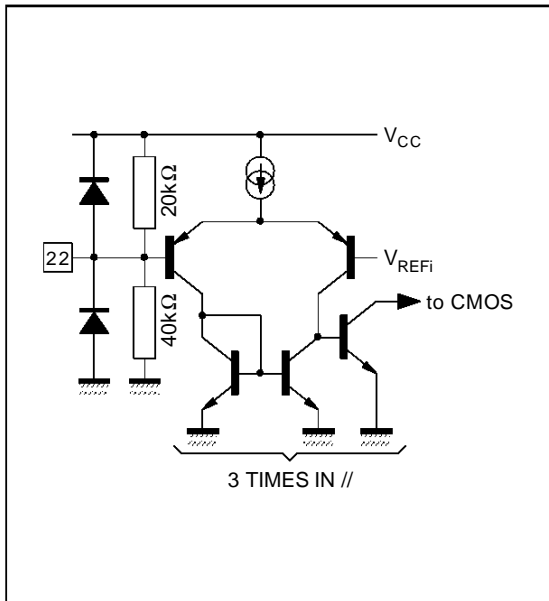
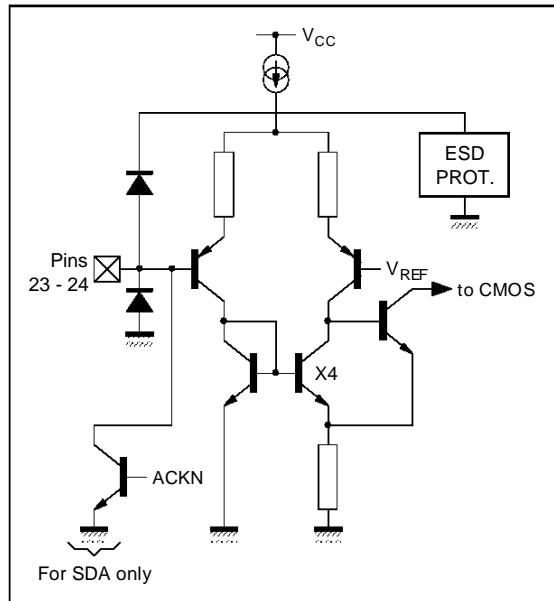
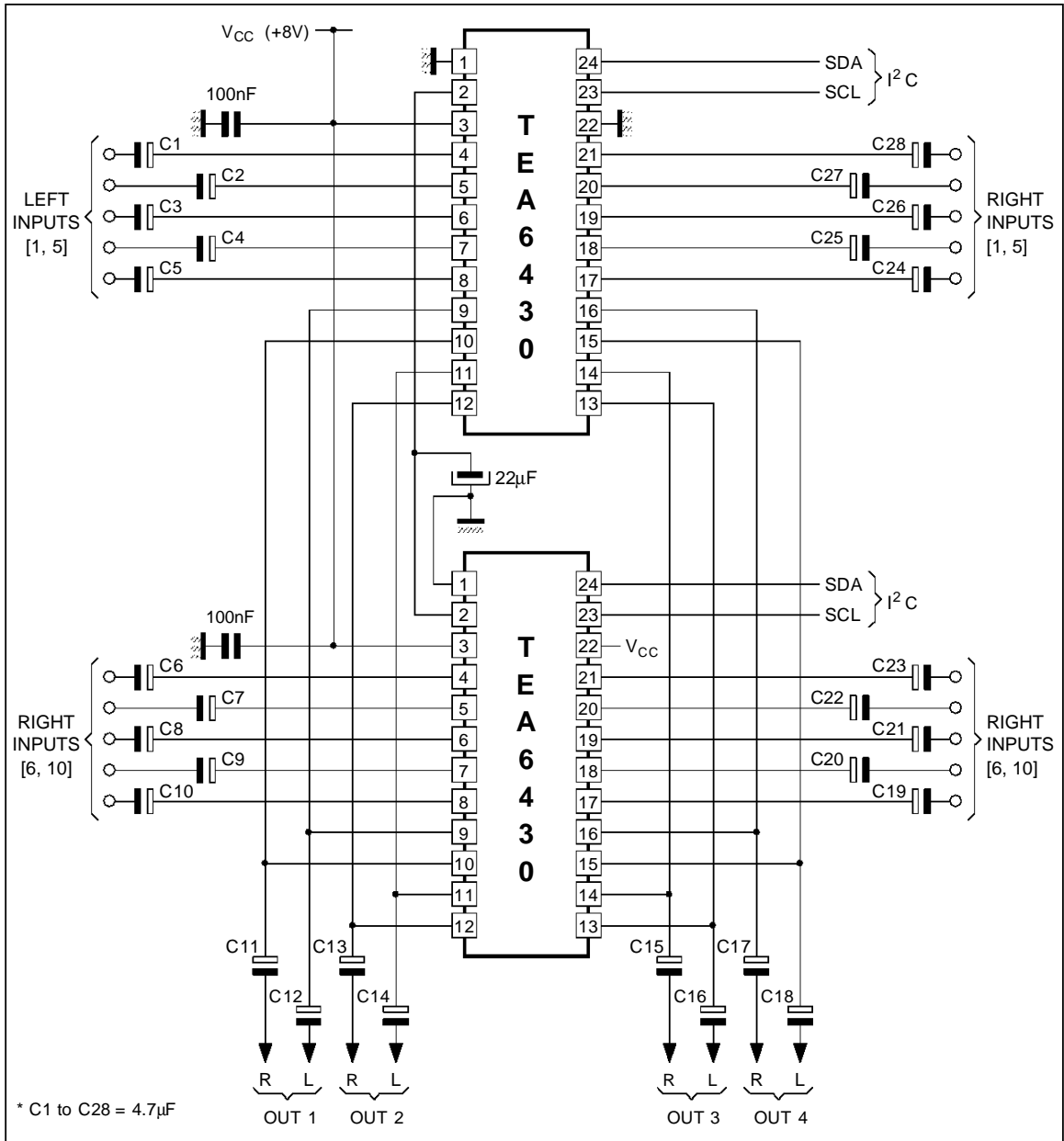

Figure 14 : Bus Inputs



TYPICAL APPLICATION



PACKAGE MECHANICAL DATA
24 PINS - PLASTIC SHRINK DIP

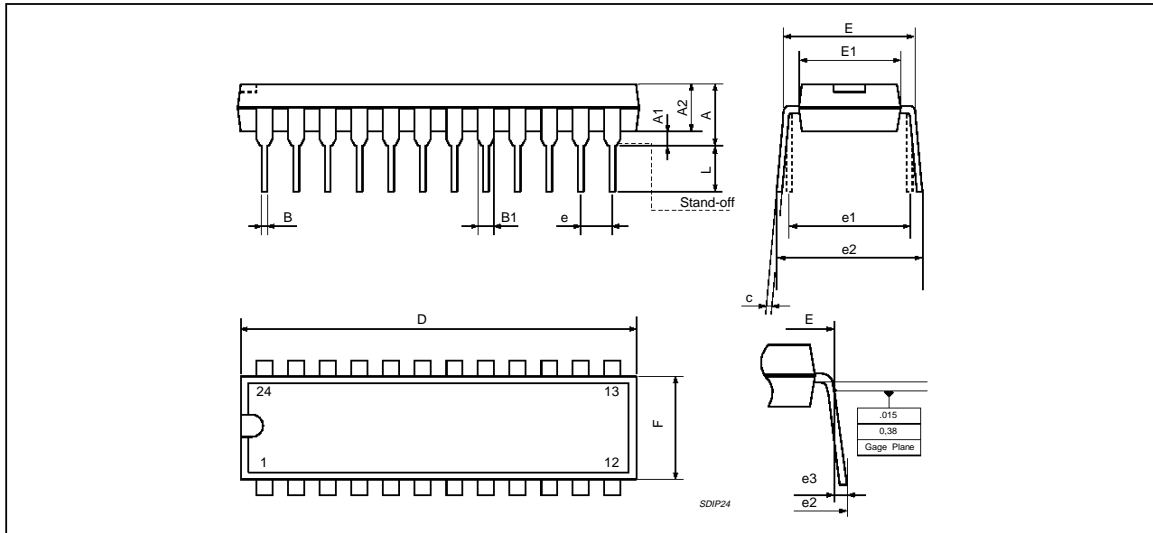

PMSDIP24.EPS

Dimensions	Millimeters			Inches		
	Min.	Typ.	Max.	Min.	Typ.	Max.
A			5.08			0.20
A1	0.51			0.020		
A2	3.05	3.30	4.57	0.120	0.130	0.180
B	0.36	0.46	0.56	0.0142	0.0181	0.0220
B1	0.76	1.02	1.14	0.030	0.040	0.045
C	0.23	0.25	0.38	0.0090	0.0098	0.0150
D	22.61	22.86	23.11	0.890	0.90	0.910
E	7.62		8.64	0.30		0.340
E1	6.10	6.40	6.86	0.240	0.252	0.270
e		1.778			0.070	
e1		7.62			0.30	
e2			10.92			0.430
e3			1.52			0.060
L	2.54	3.30	3.81	0.10	0.130	0.150

SDIP24.TBL

Information furnished is believed to be accurate and reliable. However, SGS-THOMSON Microelectronics assumes no responsibility for the consequences of use of such information nor for any infringement of patents or other rights of third parties which may result from its use. No licence is granted by implication or otherwise under any patent or patent rights of SGS-THOMSON Microelectronics. Specifications mentioned in this publication are subject to change without notice. This publication supersedes and replaces all information previously supplied. SGS-THOMSON Microelectronics products are not authorized for use as critical components in life support devices or systems without express written approval of SGS-THOMSON Microelectronics.

© 1996 SGS-THOMSON Microelectronics - All Rights Reserved

Purchase of μ C Components of SGS-THOMSON Microelectronics, conveys a license under the Philips μ C Patent. Rights to use these components in a μ C system, is granted provided that the system conforms to the μ C Standard Specifications as defined by Philips.

SGS-THOMSON Microelectronics GROUP OF COMPANIES

Australia - Brazil - Canada - China - France - Germany - Hong Kong - Italy - Japan - Korea - Malaysia - Malta - Morocco
The Netherlands - Singapore - Spain - Sweden - Switzerland - Taiwan - Thailand - United Kingdom - U.S.A.