

SPEECH CIRCUIT WITH POWER MANAGEMENT

PRELIMINARY DATA

- 2/4 WIRES INTERFACE WITH
 - double antisidetone network
 - AC impedance externally programmable
 - Rx output dynamic programmable
 - AGC attack-disconnect points programmable
- ANTI-CLIPPING/ANTI DISTORTION CIRCUIT PROGRAMMABLE
- DTMF INTERFACE
- 3.3 VOLTS SUPPLY FOR MICROPROCESSOR OR DIALER
- EXTRA CURRENT SUPPLY PROGRAMMABLE FOR LOUD SPEAKER
- DC CHARACTERISTIC PROGRAMMABLE FOR ALL SPECIFICATION
- LOW CURRENT OPERATION

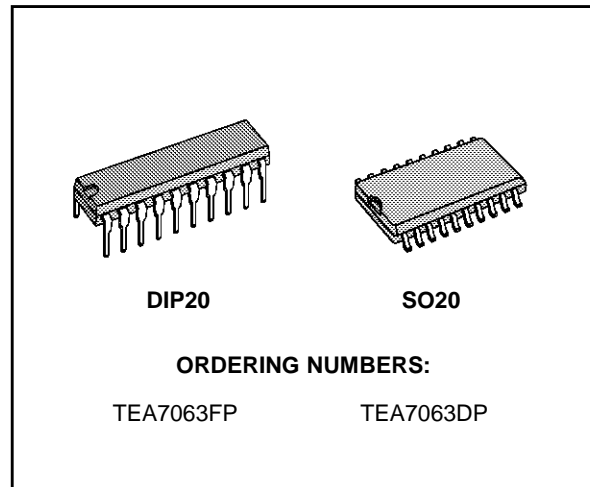

DESCRIPTION

The TEA7063 is designed to meet the different

worldwide specifications for telephone set in medium and high range equipments.

BLOCK DIAGRAM

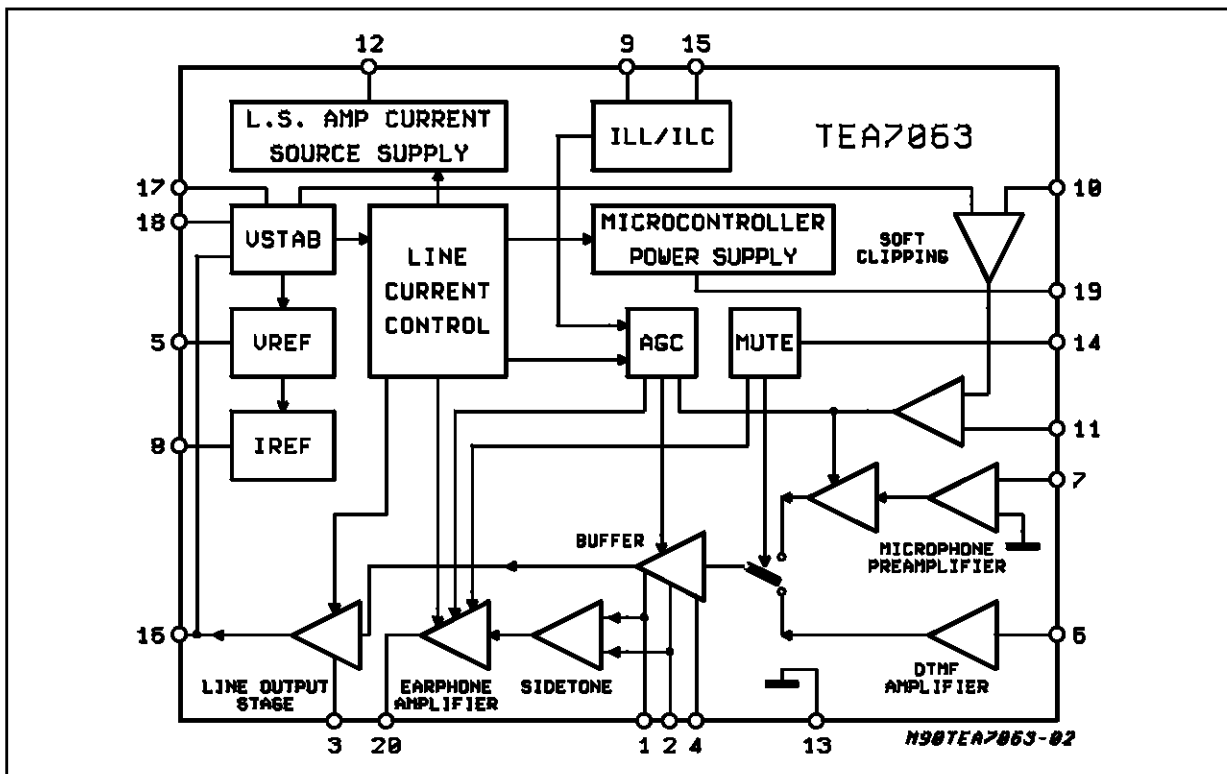

TEA7063

PIN CONNECTION (Top view)

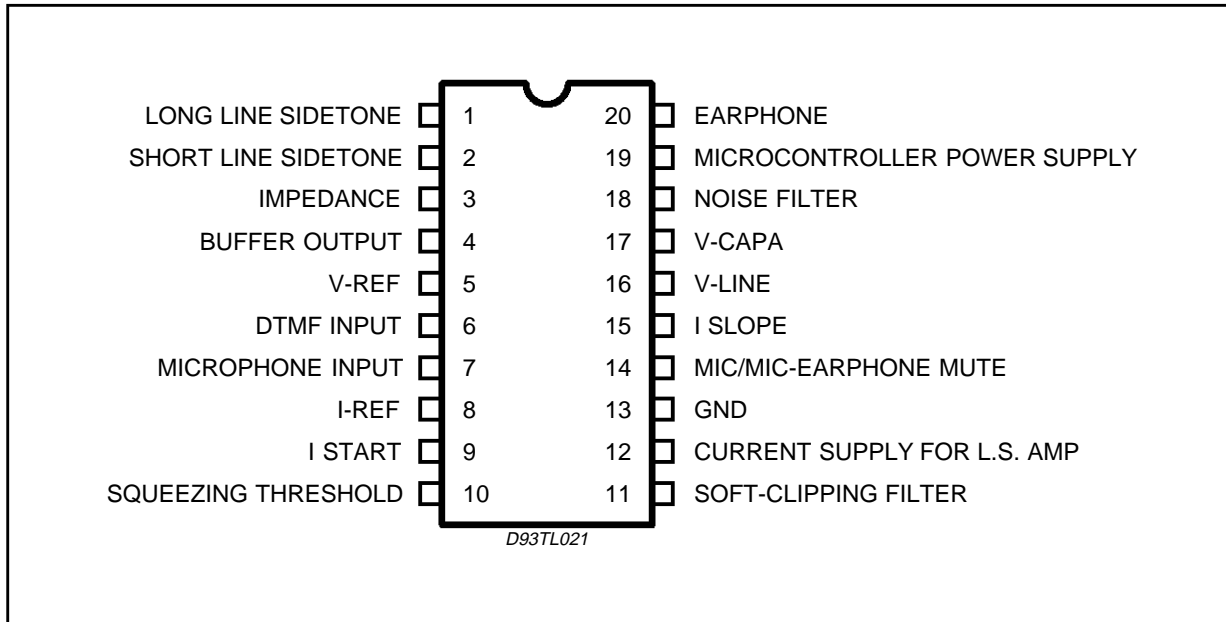

ABSOLUTE MAXIMUM RATINGS

Symbol	Parameter	Value	Unit
	Max. Current DC (steady)	150	mA
	Max. Voltage AC (steady)	7.5	V
	Max. Voltage AC + DC (steady)	9	V
	Max. Current (20ms) ONE SHOT	1	A
	Max. Voltage (20ms) ONE SHOT current < 1A	12	V
P_{tot}	Total Power Dissipation	1	W
T_J	Junction Temperature	130	°C

MAXIMUM OPERATING CONDITION

Symbol	Parameter	Value	Unit
V_{DC}	DC Voltage	7	V
V_{AC}	AC Voltage	2.2	Vp
I_{DC}	DC Current	110	mA
T_{OP}	Temperature Range	-20 to 70	°C

ELECTRICAL CHARACTERISTICS ($T_{amb} = 25^{\circ}\text{C}$; $f = 1\text{KHz}$; $R_9 = 100\text{K}\Omega$; unless otherwise specified)

Symbol	Parameter	Test Condition	Min.	Typ.	Max.	Unit
V_C	Stabilized Voltage (pin 17)	$I_L = 25\text{mA}$; $R_9 = 100\text{K}\Omega$	2.25	2.5	2.75	V
I_{int}	Internal Bias Current (pin 17)	$I_L = 25\text{mA}$ $I_L = 25\text{mA}$; $R_9 = 180\text{K}$ ($V_{16} - R_6 \cdot I_{int} + V_C$)	120	140 105	160	μA μA
V_{ref}	Reference Voltage	$I_L = 25\text{mA}$	1.05	1.2	1.35	V
I_{ref}	Current at V_{ref}		-100		+10	μA
V_{mp}	Stabilized Supply at pin 19		3.1	3.3	3.5	V
I_{cmp}	Charging Current at Pin 19	Pin 17 = GND	0.6 X I_{line}			mA
I_{spm}	Static Current at Pin 19	$I_L = 25\text{mA}$; $R_9 = 100\text{K}\Omega$	1.1	1.5		mA
		$I_L = 25\text{mA}$; $R_9 = 180\text{K}\Omega$		0.85		mA
I_{imp}	Internal Consumption		80	110	150	μA
I_{ea}	Supply Current for Parallel Circuits (pin 12)	$I_L = 25\text{mA}$	10	12		mA
		$I_L = 75\text{mA}$	50	57		mA
V_{mh} V_{mb}	Mute Microphone (pin 14)	ON	1.6			V
		OFF	0.25		0.8	V
V_{mh} V_{mb}	Mute Earphone (pin 14)	ON	2.7			V
		OFF	0.25		2.1	V
I_{mleak}	Mute Leakage Current (pin 14)	$V_{14} = 5\text{V}$			20	μA
G_S AGC_S	Tx Gain Long Line	$I_L = 25\text{mA}$	41.5	42.5	43.5	dB
			-7	-6	-5	
G_{mf}	DTMF Gain	Pin 14 > 1.6V	41.5	42.5	43.5	dB
THD_S	Tx Distortion	$I_L = 25\text{mA}$ $V_{mic} = -3\text{dBm} -GS$ $V_{mic} = -3\text{dBm} -GS + 15\text{dB}$			3	%
					10	%
Z_e	Microphone Impedance		20			$\text{K}\Omega$
N_{Tx}	Tx Noise (psometric)	$I_L = 25\text{mA}$ $2\text{K}\Omega$ at Pins 5-7		-74		dBm psoph
R_S	Tx Attenuation in Mute Mode	$I_L = 25\text{mA}$ Pin 14 > 1.6V	60			dB
G_r AGC_r	Rx Gain Long Line Line Length	$I_L = 25\text{mA}$	29	30	31	dB
			-7	-6	-5	
THD_r	Rx Distortion	$I_L = 25\text{mA}$ $V_{ro} = 500\text{mV}$ $V_{ro} = 630\text{mV}$			3	%
					10	%
N_{Rx}	Rx Noise	$I_L = 25\text{mA}$		-74		dBmp
R_r	Rx Attenuation in Mute Mode	$I_L = 25\text{mA}$ Pin = 14 > 2.7V	50			dB
G_{as}	Antisidetone	$I_L = 25\text{mA}$	22			dB
Z_{ac}	AC Impedance	$I_L = 25\text{mA}$	500	650	800	Ω
G_{rs}	Confidence Level = V_{LINE}/V_{REC} (in DTMF)	Pin 14 > 2.7V	35.5	38.5	41.5	dB
I_{ST}	Soft Clipping Current Level Control (pin 10)	$I_L = 25\text{mA}$; $R_9 = 100\text{K}\Omega$ $I_L = 25\text{mA}$; $R_9 = 180\text{K}\Omega$	2.30	2.55	2.80	mA μA
				1.4		
V_{ST}	Control Voltage Range (Pin 10)	$V_{ST} = R_{ST} \times I_{ST}$	0		1	V

CIRCUIT DESCRIPTION

1. DC CHARACTERISTICS

1.1 V_C (pin 17)

The stabilized voltage V_C is connected to V_{line} (pin 16) through an internal shunt regulator T1, T2, which presents to the line a high AC impedance at frequencies higher than 200Hz. At this purpose the value of C1 (at pin 17) must be not lower than 47µF (suggested value is 100µF).

The shunt regulator, T1 and T2, also controls the extra current source, or power management, at pin 12 (see also paragraph 6).

1.2 V_{LINE} (pin 16)

The line voltage (pin 16) is determined by the value of the external resistor R6 and by the internal current, I_{int}, flowing between V_C (pin 17) and

Ground (see also paragr.: 1.1):

$$V_{LINE} = V_C + R_6 \times I_{int}$$

V_C is fixed by design at about 2.5V.

I_{int} is reversely related to R9:

$$I_{int} = 8 \text{ Volt}/R9 + 60\mu\text{A} \text{ at } I_L > 25\text{mA}$$

$$I_{int} = 4 \text{ Volt}/R9 + 60\mu\text{A} \text{ at } I_L = 6\text{mA}$$

where I_L depends on I_{LB} (see supply management)

V_{LINE} must be externally adjusted (with R6) to guarantee both DC and AC characteristic in accordance to the specific standard of the different administrations.

Another adjustment of the DC characteristic is possible with R9. Increasing the value of R9 causes a decrease of I_{int} and consequently a reduction of the product I_{int} x R9. (see also Paragraph 7)

Figure 1

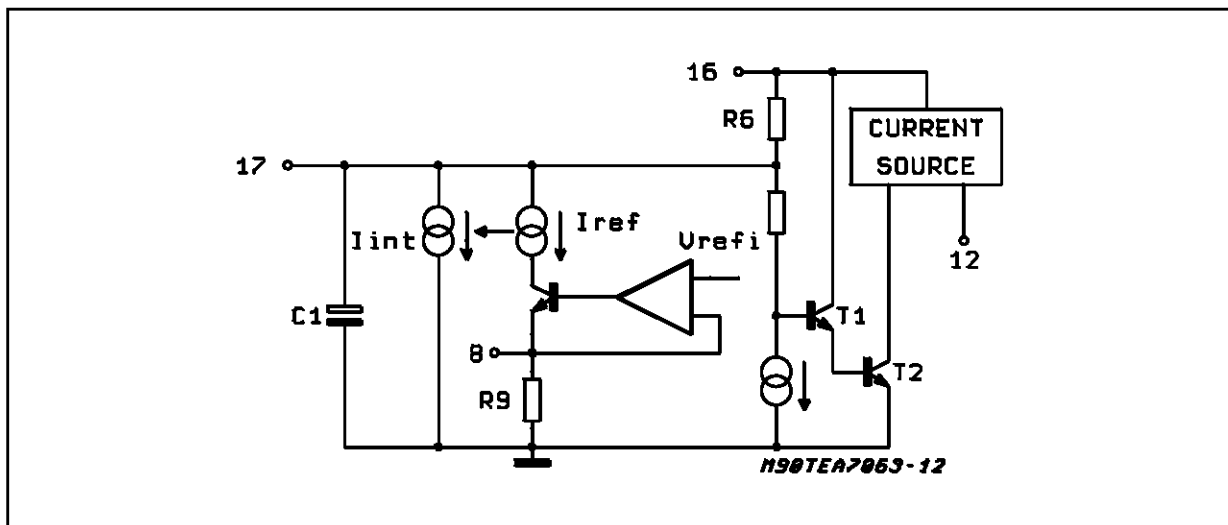
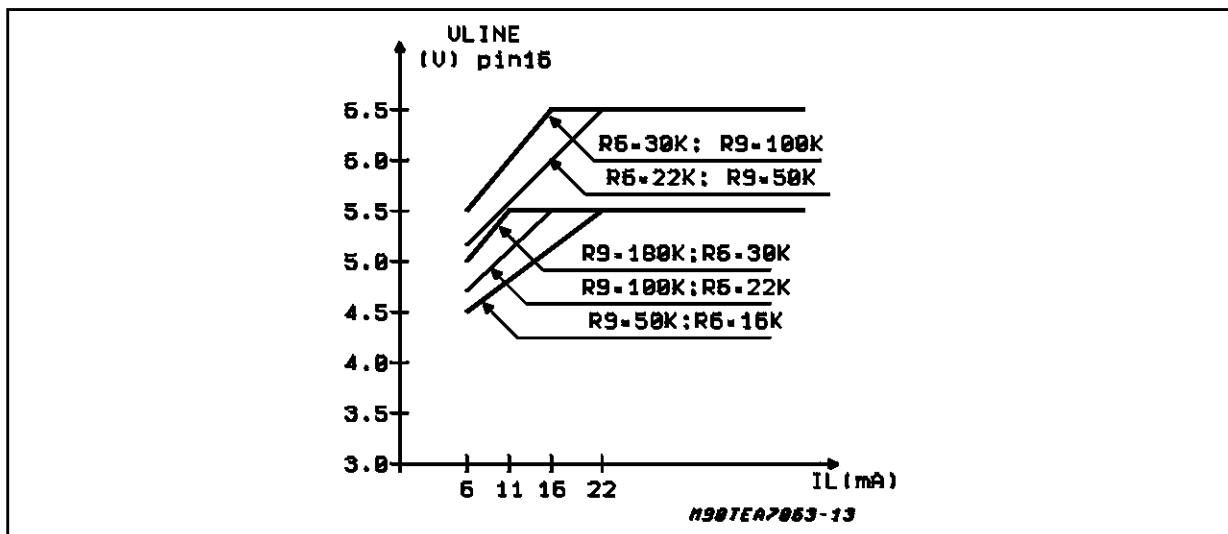

Figure 2



2. TRANSMISSION CHAIN

2.1 A.G.C. In Transmission

The transmission gain between Microphone Input (pin 7) and Vline (pin 16) is internally decreased of 6dB when the line current varies from ILL to ILS with a constant AC load of 600Ω.

The values of ILL (long line current) and ILS (short line current) are programmable through I-start (pin 9) and I-slope (pin 15) (see also paragr. 4).

2.2 Sending Impedance

The impedance of the Output Stage Amplifier, Z_{out} , is determined by the impedance Z_4 (at pin 3).

$$Z_{out} = 10.65 \times Z_4$$

The total AC impedance shown to the line is the parallel

$$Z_{par} = Z_{out} // Z_{int} // Z_{ext}$$

where:

- $Z_{int} = 10K\Omega // 8.5 \text{ nF}$ (internal)
- $Z_{ext} = R_6 // C_4$ (at pin 16)

2.3 Sending Mute

In normal speech operation (V_{mute} at pin 14 < 0.8V), the signal at Microphone Input (pin 7) is amplified to V_{line} (pin 16) with the gain G_s (long line) or 6dB lower (shorter lines) depending on AGC control (see paragr. 4).

In sending mute condition ($V_{14} > 1.6V$) these gains are reduced of at least 60dB. In the same condition, DTMF input (pin 6) is activated, with gain G_{mf} to the line independent from l_{line} length.

2.4 Antisidetone Buffer

The signal coming from the sending preamplifier is internally presented at pin 4 and than buffered to pins 1 and 2 for sidetone cancellation (see paragraph 3.2).

Figure 3

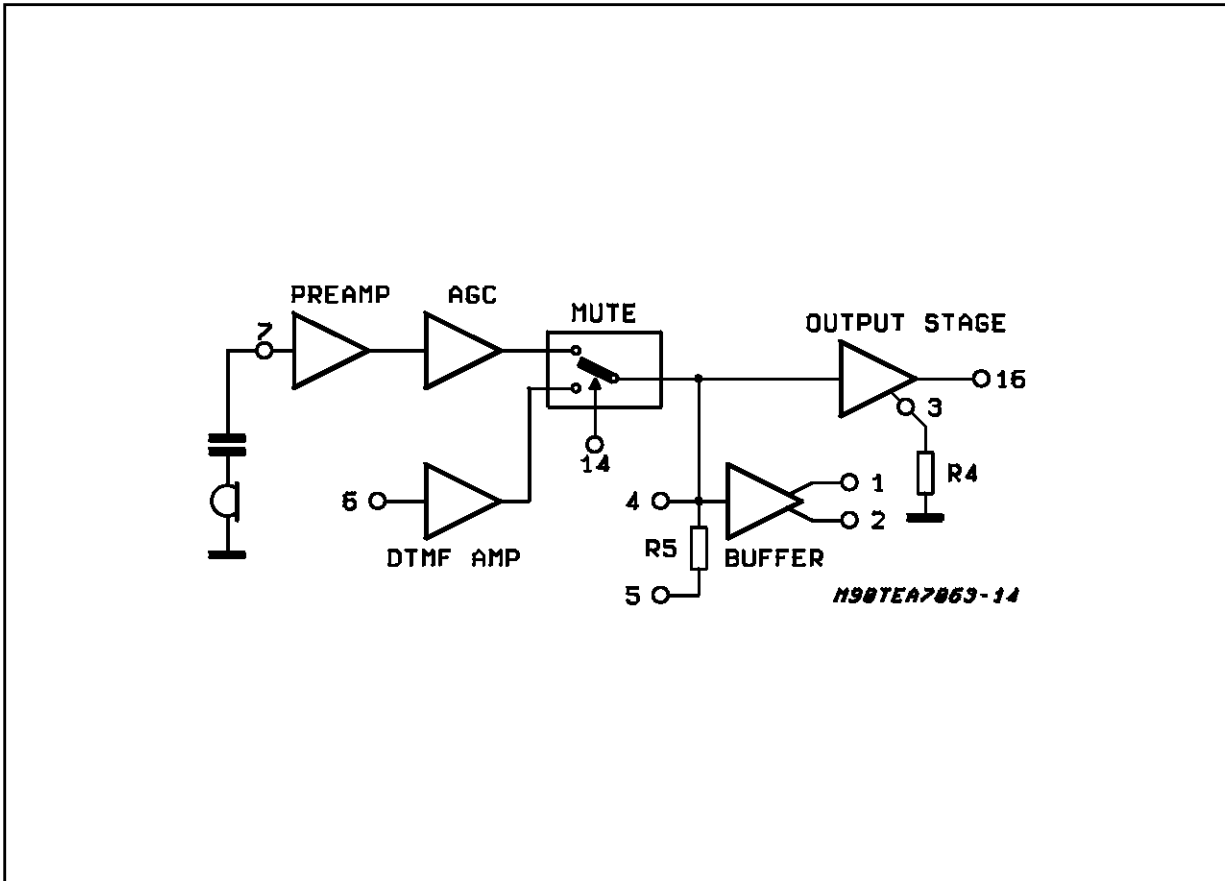

2.5 Soft Clipping

To avoid distortion on line, the TEA7063 has a "soft clipping" on transmit channel.

The resistor (Rsoft) on pin 10 fixes the maximum AC peak dynamic on the line: VSTL

$$V_{STL}(V_p) = V_{pin16}(DC) - 1.44 \cdot \frac{R_{soft} (\text{pin } 10)}{R_9 (\text{pin } 8)}$$

$$\text{where } R_{soft} \leq \frac{1V}{I_{ST}} \quad I_{ST} = \frac{470mV}{2 \cdot R_9 (\text{pin } 8)}$$

The capacitor (C10) and the resistor (R10) connected on pin 11 fix the constant time of the soft clipping.

Recommended values: C10 = 150nF; R10 = 560KΩ

Figure 4

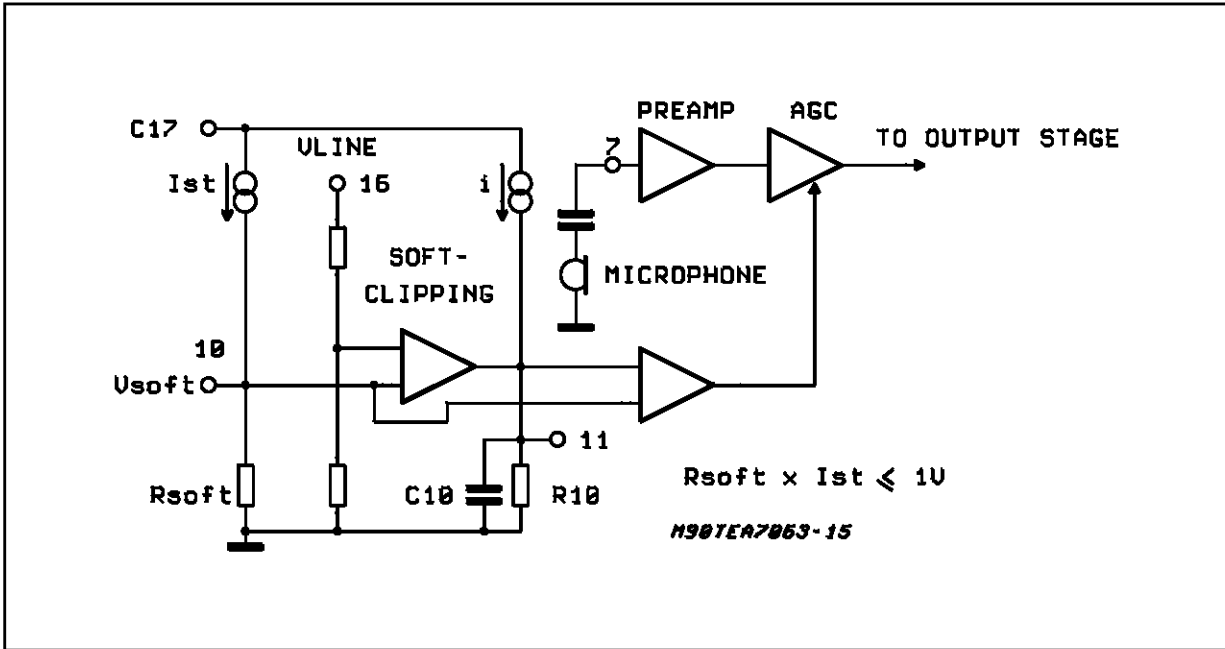
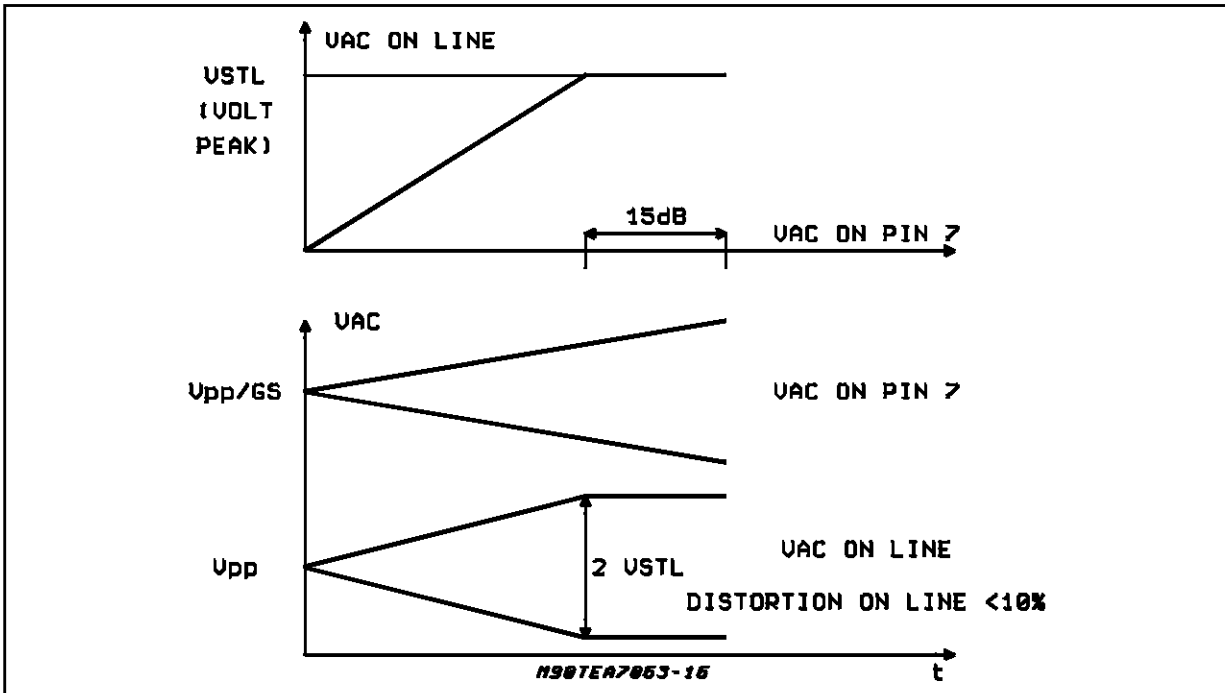

Figure 5: Transmit Curves



3. RECEIVE CHAIN

3.1 A.G.C. In Receive

As described for the transmission chain, also the receiving gains G_r , from pins 1 and 2 to pin 20, have a reduction of 6dB when l_{line} moves from ILL to ILS (see also paragr. 4).

3.2 Sidetone Compensation

The circuit is provided with a double anti-sidetone network to optimize both at long and short lines.

In case double antisidetone network is not requested by the application needs, pins 1 and 2 can be connected to each other and 5 external passive components can be saved (ZALL and ZRL).

Before entering pins 1 and 2, the received signal is reduced by the two attenuating networks:

- ZALL/ZRL to pin 1 for long lines sidetone compensation,
- ZALS/ZRS to pin 2 for short lines sidetone compensation.

ZRL and ZRS define the total receive gains:

$$a) \frac{V_{20}}{V_{16}} = G_r \cdot \frac{Z_{RL}}{Z_{RL} + Z_{ALL}} \text{ for long lines}$$

b)

$$\frac{V_{20}}{V_{16}} = (G_r - 6\text{dB}) \cdot \frac{Z_{RS}}{Z_{RS} + Z_{ALS}} \text{ for short lines}$$

ZALL and ZALS define the sidetone compensation of the circuit.

The equivalent balancing impedance is given by the formula:

$$Z_{AL} = K \cdot Z_{ALS} + (1 - K) \cdot Z_{ALL}$$

where:

- $K = 0$ at $l_{LINE} = ILL$ or lower (long line)
- K varies linearly from 0 to 1 with l_{line} between ILL and ILS
- $K = 1$ at $l_{LINE} = ILS$ or higher (short line)..

Calculations to define ZALL and ZALS are:

$$a) \quad Z_{ALL} = 70 \cdot R_5 \cdot \frac{Z_{line}(\text{long}) // Z_{ext} // Z_{int} // Z_{out}}{Z_{out}}$$

$$b) \quad Z_{ALL} = 70 \cdot R_5 \cdot \frac{Z_{line}(\text{short}) // Z_{ext} // Z_{int} // Z_{out}}{Z_{out}}$$

where:

- $Z_{ext} = R_6 // C_4 // (Z_{electret})$ (at pin 13)
- $Z_{int} = 10K\Omega // 8.5nF$ (internal impedance)
- $Z_{out} = 10.65 \cdot Z_4$ (at pin 3; see paragr. 2.2)
- $Z_{line}(\text{short})$ and (long) are the impedances of the line at minimum and maximum line length
- $R_5 = 5.1K\Omega \pm 1\%$ (typically)

3.3 AC Impedance

The total AC impedance of the circuit to the line is:

$$Z_{AC} = Z_{out} // Z_{int} // Z_{ext} \quad (Z_{ALS}, Z_{ALL} \gg Z_{AC})$$

3.4 Receive Mute (and confidence level)

When the receive channel is muted ($V_{pin 14} > 2.7V$) the receive gain is reduced of 60dB minimum.

Figure 6

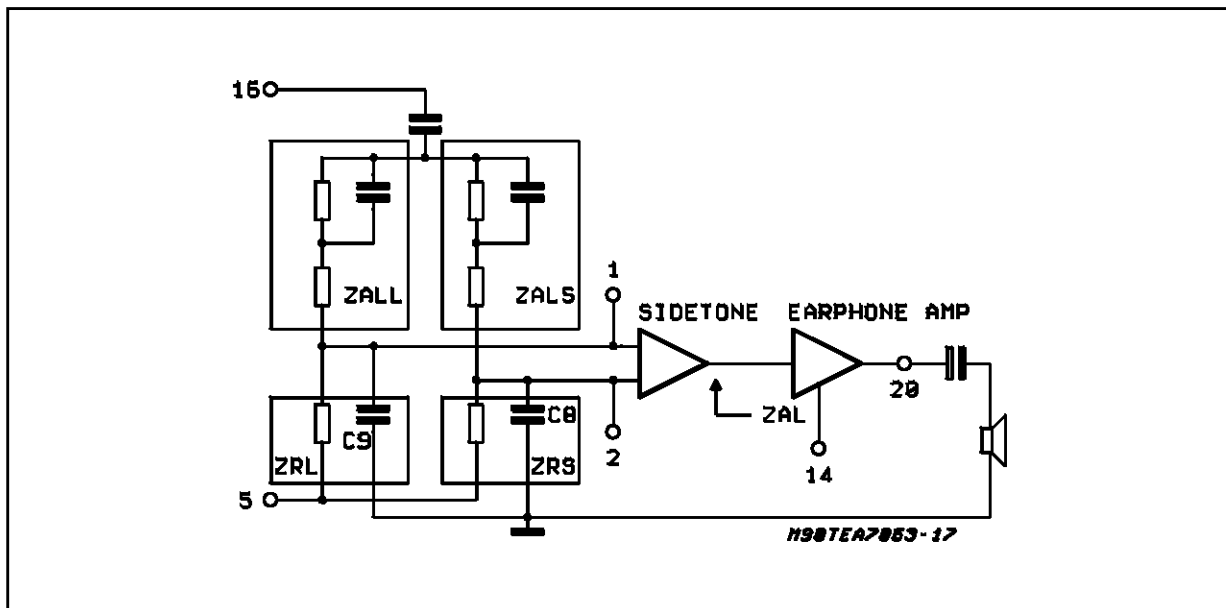

In this condition an internal connection is activated from line DTMF output (pin 16) to Receive Output (pin 20) with an attenuation GRS = 38.5dB to provide acoustic feedback of the DTMF emission.

4. A.G.C AND SIDETONE PROGRAMMING

4.1 Programmable Controls

AGC and sidetone attack and disconnect points (or currents) are programmable externally through two independent pins, I-start (pin 9) and I-slope (pin 15).

4.2 I-Start (pin 9)

An external resistor RLL connected between I-start (pin 9) and Microprocessor Supply (pin 19) controls the attack point of AGC and ZAL (antidetone Z).

ILL is the line current at which the control starts. Formulas for ILL and RLL with R9 = 100K are:

$$ILL = \frac{2880}{RLL} + 11\text{mA}$$

$$RLL = \frac{2880}{(ILL - 11\text{mA})}$$

4.3 I-Slope (pin 15)

An external resistor RLS connected between I-slope (pin 15) and Microprocessor Supply (pin 19) controls the disconnected point of AGC and

ZAS (antidetone Z). ILS is the line current at which the control stops. Formulas for ILS and RLS with R9 = 100K are:

$$ILS = \frac{4680}{RLS} + ILL;$$

$$RLS = \frac{4680}{(ILS - ILL)}$$

4.4 A.G.C. OFF (pin 9 and 15)

Programming ILL and ILS respectively higher than 70mA and 450mA is forcing the IC in AGC OFF Condition.

Suggested external components are:

RLL = 51K Ω and RLS = 10K Ω

In this case sending, receiving gain and sidetone compensation are independent of the line length. Pins 1 and 2 can be connected to each other saving 5 passive external components at pin 2.

4.5 Secret Function for Private (pin 14)

The two separate thresholds for sending and Receiving Mute (pin 14) allow "Secret Function" (only microphone muted).

Pin 14 can be set:

- between 0.25V and 0.8V for speech mode,
- between 1.6V and 2.1V for "secret" mode (microphone muted),
- between 2.7V and 3.3V for "all muted" mode

Figure 7

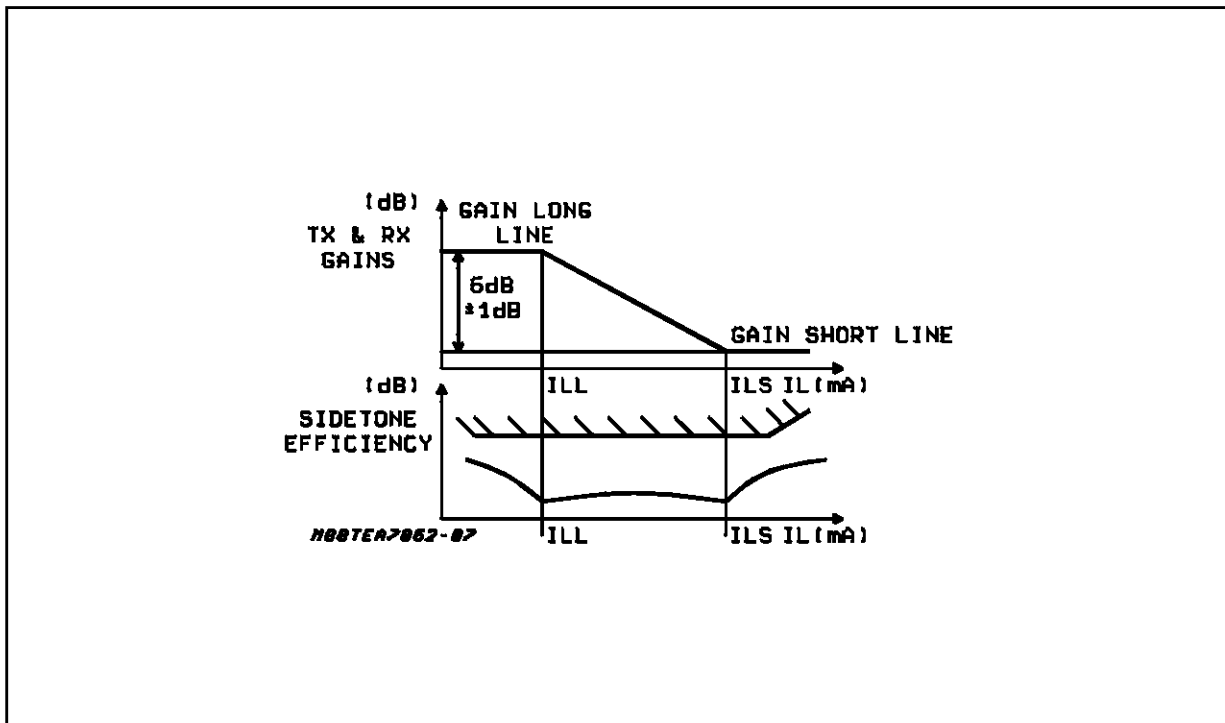

5. MICROPROCESSOR INTERFACE

5.1 Microprocessor Supply (pin 19)

At "off-hook" the first priority of the circuit is to make some current available at the Microprocessor Supply (pin 19) to charge quickly the external capacitor C2.

This charging current is $I_{cpm} = 0.6 \cdot I_{LINE}$

T-charge of about 10ms is necessary, with $C2 = 47\mu F$. to charge pin 19 at the specified value of 3.3V typical at $I_{LINE} = 25mA$:

$$T\text{-charge} = \frac{3.3V \cdot C2}{0.6 \cdot I_{LINE}} \text{ typically}$$

$V_{mp} = 3.3V$ in normal operation and current increases linearly from 0.5mA min, at $I_{LINE} = 6mA$, to 1.5mA, at $I_{LINE} = 25mA$, remaining stable for higher values of I_{LINE} . (with $R9 = 100K$)

In general:

$$I_{mp} = \frac{130\text{Volt}}{R9} + 0.3mA \text{ at } I_L > 25mA$$

$$I_{mp} = \frac{11\text{Volt}}{R9} + 0.3mA \text{ at } I_L > 6mA$$

A zener of 3.9V typical is generally suggested to

Figure 8

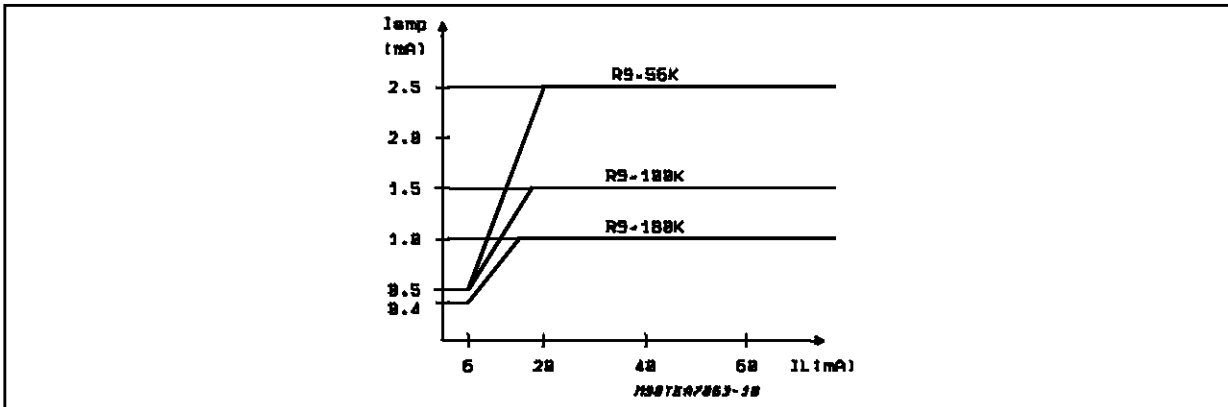

6. CURRENT SOURCE FOR SPEAKERPHONE

6.1 Current Source (pin 12)

Most of the DC current available from the line is delivered by the speech circuit at the output I_{source} (pin 12) through an internal current generator.

Typical values of this current, I_{LS} with $R9 = 100K$, are:

$$I_{LS} = (0.3 \cdot I_{LINE}) \text{ for } I_{LINE} < 16.5mA$$

$$I_{LS} = (0.9 \cdot I_{LINE} - 10mA) \text{ for } I_{LINE} > 16.5mA$$

(ex: $I_{LINE} = 16mA$ then $I_{LS} = 5mA$)

$I_{LINE} = 30mA$ then $I_{LS} = 17mA$

$I_{LINE} = 60mA$ then $I_{LS} = 44mA$.

The voltage level at pin 12 must be defined by an external regulator (i.e.: zener) and, if necessary, filtered with a capacitor (47 to 220 μF).

In case V_{LINE} (at pin 16) approaches voltage at pin 12, then the internal current source switches off and its DC current is shunt to ground through and internal complementary generator, thus avoiding any negative effect on the AC and DC impedances of the telephone set application.

Figure 9

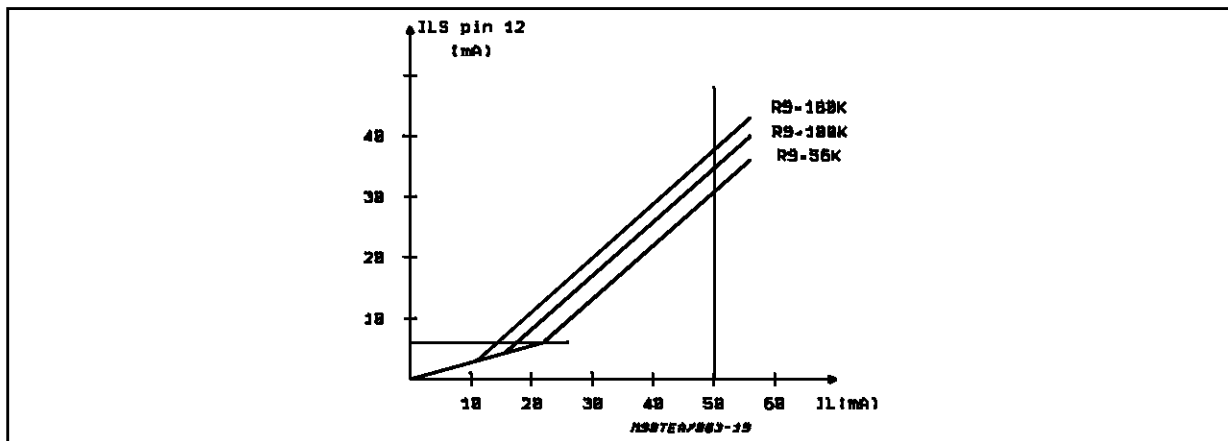

7. INTERNAL DESCRIPTION OF CURRENT MANAGEMENT

7.1 Internal Power Supply Management

R9 fixes the line power supply management.
R9 fixes the values of: I_{ear} , I_{up} , I_{ref} and ILS.

A current line information is used to modify the values of I_{ear} , I_{up} , I_{ref} and ILS between a minimum and a maximum values.

On Fig 10:

The transmit output stage is represented by a current source (I_{tr}). The I_{tr} value depends of the DC voltage on V_{LINE} (pin 16) and R_{ZAC} value.

The other internal stages connected to V_{LINE} (pin 16) are represented by a constant 1.3mA current source.

7.2 DC Characteristics (internal)

The DC characteristic is equals to:

$$V_{LINE} \text{ (pin 16)} = V_C \text{ (pin 17)} + R_6 \cdot I_{int}$$

I_{int} is the sum of all the current sources connected on V_C (pin 17):

$$[I_p + I_{ref} + V_{pin17} / (r_7 + r_8)]$$

- I_p is the bias internal operational amplifiers power supply.

$$- I_{ref} = 1 / 3 \cdot (V_{refi} / R_9); \text{ with } V_{refi} = 470\text{mV}$$

$$- I_{ref} = 156 / R_9 \text{ mA}$$

The current line information changes I_{int} value;

$$\text{at low line current (6mA): } I_{int} = 4V / R_9 + 60\mu\text{A}$$

$$\text{at low line current (IL = ILb): } I_{int} = 8V / R_9 + 60\mu\text{A}$$

7.3 Microcontroller Supply (internal)

$$I_{up} = [(p_2 / r_2) \cdot I_{ref} + 0.3] \text{ mA} = [(p_2 / r_2) \cdot 156 / R_9 + 0.3] \text{ mA}$$

The current line information changes p_2/r_2 value;

$$\text{at low line current (6mA): } p_2 / r_2 = 70$$

$$\text{at a line current (IL = ILb): } p_2 / r_2 = 820$$

7.4 Earphone Current Supply (internal)

$$I_{ear} = (p_1 / r_1) \cdot I_{ref} \text{ mA} = (p_1 / r_1) \cdot (156 / R_9) \text{ mA}$$

The current line information changes p_1/r_1 value;

$$\text{at low line current (6mA): } p_1 / r_1 = 200$$

$$\text{at a line current (IL = ILb): } p_1 / r_1 = 2700$$

The maximum peak dynamic on the earphone is:

$$V_{pear} = Z_{ear} \cdot I_{ear}$$

7.5 Transmit Output Stage (internal)

The output stage bias current depends of the DC voltage on pin 16 and on R_{ZAC} impedance.

$$I_{tr} = \frac{0.1425 \cdot V_{LINE} - 0.517}{R_Z} \text{ (R}_Z \text{ is the resistor connected between pin3 and the ground)}$$

7.6 Loudspeaker Current Source (internal)

The current source for external peripherals has two slopes:

- First slope; before I_{ear} , I_{up} , I_{tr} and I_{int} are stabilized at their maximum values: (IL = ILb)

$$ILS = 0.285 \cdot IL$$

- Second slope; after I_{ear} , I_{up} , I_{tr} and I_{int} are stabilized at their maximum values: (for IL > ILb)

$$\Delta (ILS) = 0.91 \cdot \Delta (I_{LINE})$$

I_{ear} , I_{up} , I_{tr} and I_{int} are stabilized at their maximum values between 16 and 26mA, the absolute IL value depends of R9 value. The line current (ILb) where I_{ear} , I_{up} , I_{tr} , I_{int} are stabilized at their maximum values and where the slope of ILS change is:

$$ILb = \frac{I_{ear} + I_{up} + I_{tr} + I_{int} + 1.3}{0.715}$$

7.7 Numerical Example

1) R9 = 100K Ω ; R6 = 25K Ω

- ◆ DC characteristic = 6V for I_{int} max:
= 5V for I_{int} min:

$$I_{int} \text{ min (IL = 6mA)} = 4 / 100K + 60 = 100\mu\text{A}$$

$$I_{int} \text{ min (IL = ILb)} = 8 / 100K + 60 = 140\mu\text{A}$$

$$V_{pin17} = 2.5V \Rightarrow R_6 = 25K\Omega \Rightarrow$$

$$V_{pin16} \text{ min (IL = 6mA)} = 2.5 + 25 \cdot 100E - 3 = 5V$$

$$V_{pin16} \text{ max (IL = ILb)} = 2.5 + 25 \cdot 140E - 3 = 6V$$

- ◆ Current Sources

$$I_{up} \text{ min (IL = 6mA)} = 0.4\text{mA}$$

$$I_{up} \text{ max (IL = ILb)} = 1.6\text{mA}$$

$$I_{ear} \text{ min (IL = 6mA)} = 0.3\text{mA}$$

$$I_{ear} \text{ max (IL = ILb)} = 4.2\text{mA}$$

with $R_Z = 75\Omega$

$$I_{tr} \text{ min (IL = 6mA)} = 2.6\text{mA}$$

$$I_{tr} \text{ max (IL = ILb)} = 4.5\text{mA}$$

$$ILS \text{ min (IL = 6mA)} = 1.3\text{mA}$$

$$\text{◆ } ILb = \frac{1.6 + 4.2 + 4.5 + 0.14 + 1.3}{0.715} \text{ mA}$$

$$ILb = 16.5\text{mA}$$

$$ILS \text{ (for IL = ILb)} = 0.285 \cdot ILb = 4.7\text{mA}$$

- ◆ at IL = 100mA:

$$\Delta (ILS) = 0.91 \cdot \Delta (IL) = 0.91 \cdot (100 - 16.5) = 76\text{mA}$$

$$ILS = 4.7 + 76 = 80.7\text{mA}$$

2) R9 = 56K Ω ; R6 = 18K Ω

- ◆ DC characteristic = 6.1V for I_{int} max:
= 4.8V for I_{int} min:

TEA7063

$$I_{\text{int min}} (I_L = 6\text{mA}) = 4 / 56\text{K} + 60 = 130\mu\text{A}$$

$$I_{\text{int min}} (I_L = I_{Lb}) = 8 / 56\text{K} + 60 = 200\mu\text{A}$$

$$V_{\text{pin17}} = 2.5\text{V} \Rightarrow R_6 = 18\text{K}\Omega \Rightarrow$$

$$V_{\text{pin16 min}} (I_L = 6\text{mA}) = 2.5 + 18 \cdot 130\text{E}^{-3} = 4.85\text{V}$$

$$V_{\text{pin16 max}} (I_L = I_{Lb}) = 2.5 + 18 \cdot 200\text{E}^{-3} = 6.1\text{V}$$

◆ Current Sources

$$I_{\text{up min}} (I_L = 6\text{mA}) = 0.5\text{mA}$$

$$I_{\text{up max}} (I_L = I_{Lb}) = 2.5\text{mA}$$

$$I_{\text{ear min}} (I_L = 6\text{mA}) = 0.55\text{mA}$$

$$I_{\text{ear max}} (I_L = I_{Lb}) = 7.5\text{mA}$$

with $R_z = 75\Omega$

$$I_{\text{tr min}} (I_L = 6\text{mA}) = 2.35\text{mA}$$

$$I_{\text{tr max}} (I_L = I_{Lb}) = 4.5\text{mA}$$

$$I_{\text{LS min}} (I_L = 6\text{mA}) = 1.17\text{mA}$$

$$\begin{aligned} \text{◆ } I_{Lb} \\ I_{Lb} = \frac{2.5 + 7.5 + 4.5 + 0.2 + 1.3}{0.715} \text{ mA} \end{aligned}$$

$$I_{Lb} = 22.4\text{mA}$$

$$I_{\text{LS}} (\text{for } I_L = I_{Lb}) = 0.285 \cdot I_{Lb} = 6.4\text{mA}$$

◆ at $I_L = 100\text{mA}$:

$$\Delta(I_{\text{LS}}) = 0.91 \cdot \Delta(I_L) = 0.91 \cdot (100 - 22.6) = 64\text{mA}$$

$$I_{\text{LS}} = 6.4 + 64 = 70.4\text{mA}$$

Figure 10: Line Power Supply Management

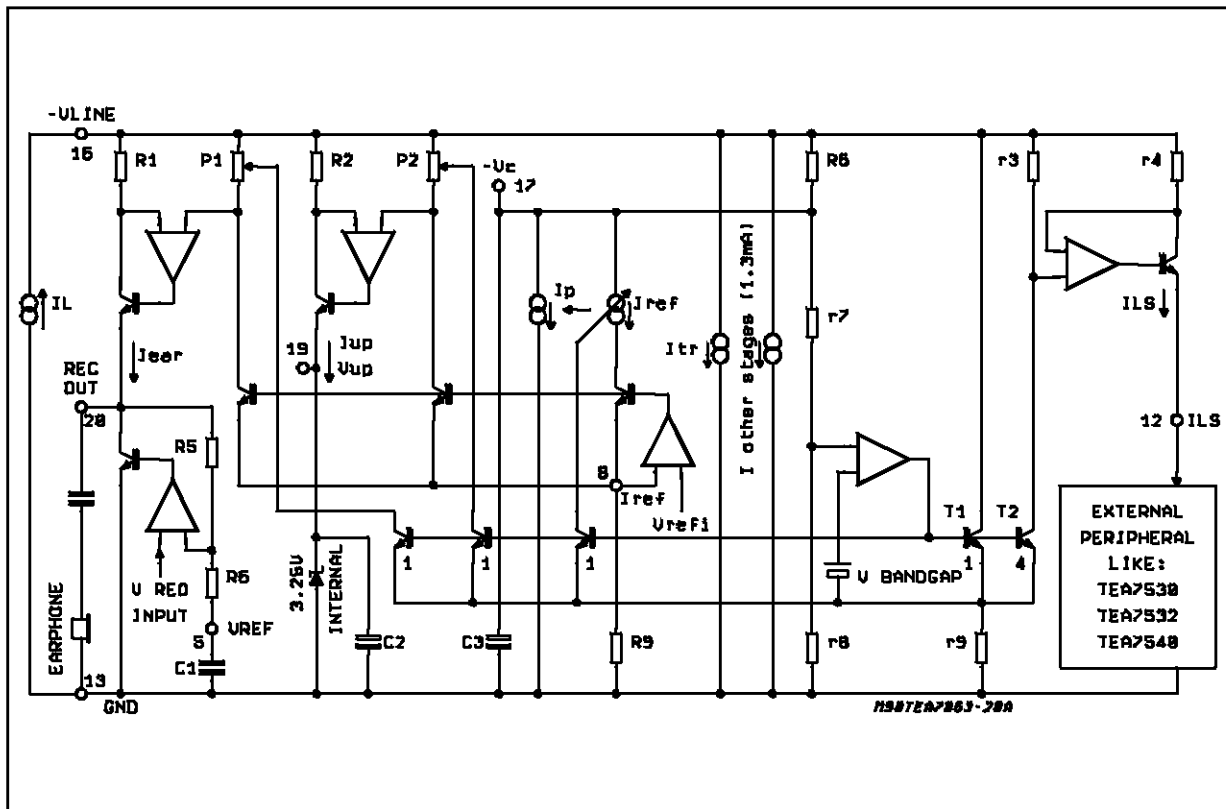

SO20 PACKAGE MECHANICAL DATA

DIM.	mm			inch		
	Min.	Typ.	Max.	Min.	Typ.	Max.
A			2.65			0.104
a1	0.1		0.2	0.004		0.008
a2			2.45			0.096
b	0.35		0.49	0.014		0.019
b1	0.23		0.32	0.009		0.013
C		0.5			0.020	
c1	45° (typ.)					
D	12.6		13.0	0.496		0.510
E	10		10.65	0.394		0.419
e		1.27			0.050	
e3		11.43			0.450	
F	7.4		7.6	0.291		0.300
L	0.5		1.27	0.020		0.050
M			0.75			0.030
S	8° (max.)					

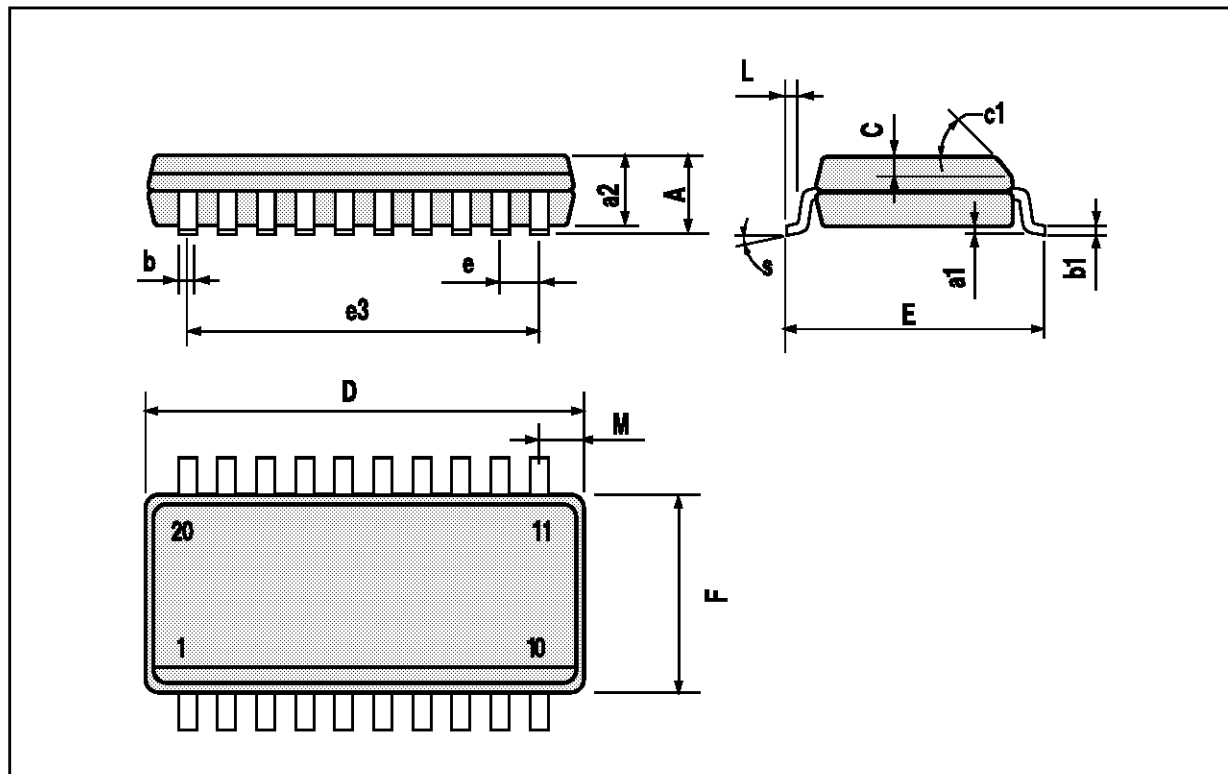

DIP20 PACKAGE MECHANICAL DATA

DIM	mm			inch		
	Min.	Typ.	Max.	Min.	Typ.	Max.
a1	0.254			0.010		
B	1.39		1.65	0.055		0.065
b		0.45			0.018	
b1		0.25			0.010	
D			25.4			1.000
E		8.5			0.335	
e		2.54			0.100	
e3		22.86			0.900	
F			7.1			0.280
i			3.93			0.155
L		3.3			0.130	
Z			1.34			0.053

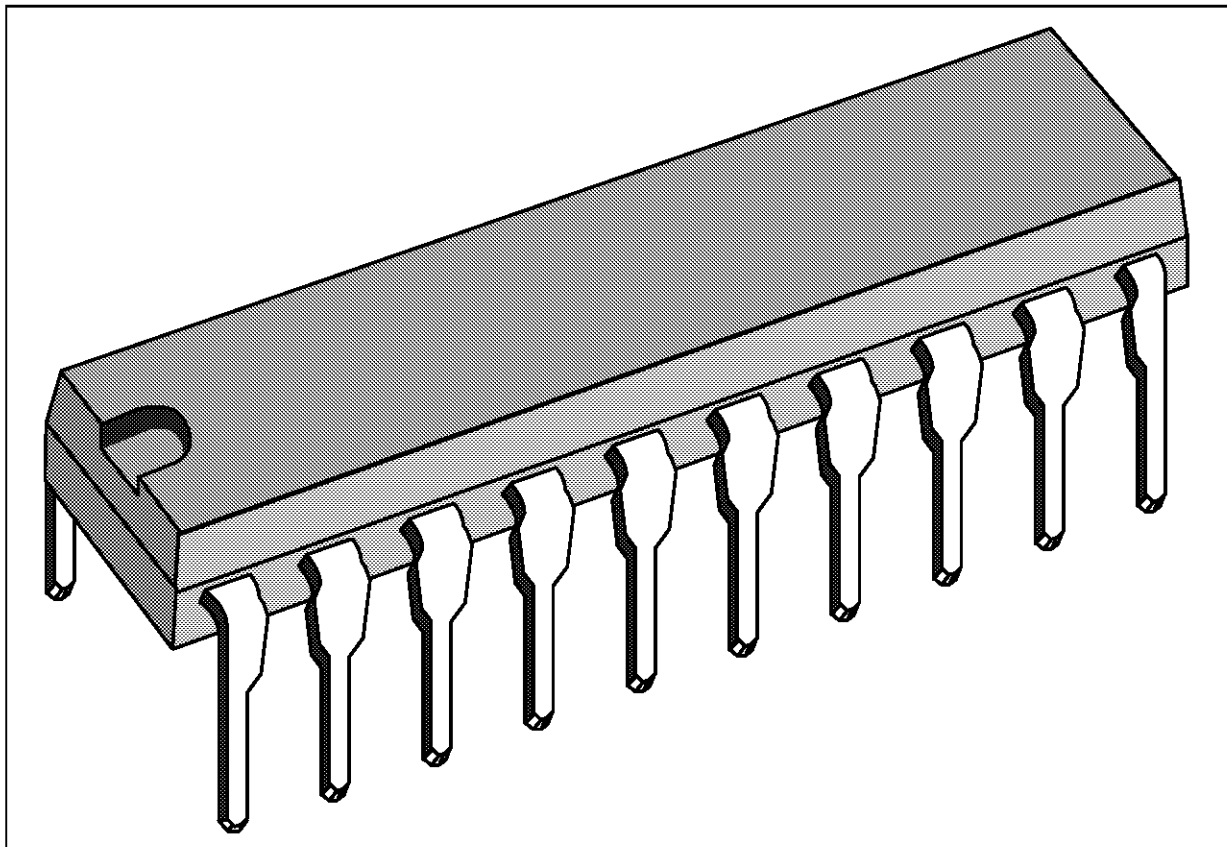

Information furnished is believed to be accurate and reliable. However, SGS-THOMSON Microelectronics assumes no responsibility for the consequences of use of such information nor for any infringement of patents or other rights of third parties which may result from its use. No license is granted by implication or otherwise under any patent or patent rights of SGS-THOMSON Microelectronics. Specifications mentioned in this publication are subject to change without notice. This publication supersedes and replaces all information previously supplied. SGS-THOMSON Microelectronics products are not authorized for use as critical components in life support devices or systems without express written approval of SGS-THOMSON Microelectronics.

© 1994 SGS-THOMSON Microelectronics - All Rights Reserved

SGS-THOMSON Microelectronics GROUP OF COMPANIES

Australia - Brazil - France - Germany - Hong Kong - Italy - Japan - Korea - Malaysia - Malta - Morocco - The Netherlands
Singapore - Spain - Sweden - Switzerland - Taiwan - Thailand - United Kingdom - U.S.A.