

TRIAC (ISOLATED TYPE)

TG35C/E/D



UL;E76102 (M)

TG35C/E/D are isolated molded triacs suitable for wide range of applications like copier, microwave oven, solid state switch, motor control, light control and heater control.

- $I_T(AV)$ 35A
- High surge capability 330A
- Isolated Nounting (AC2500V)
- Tab Terminals

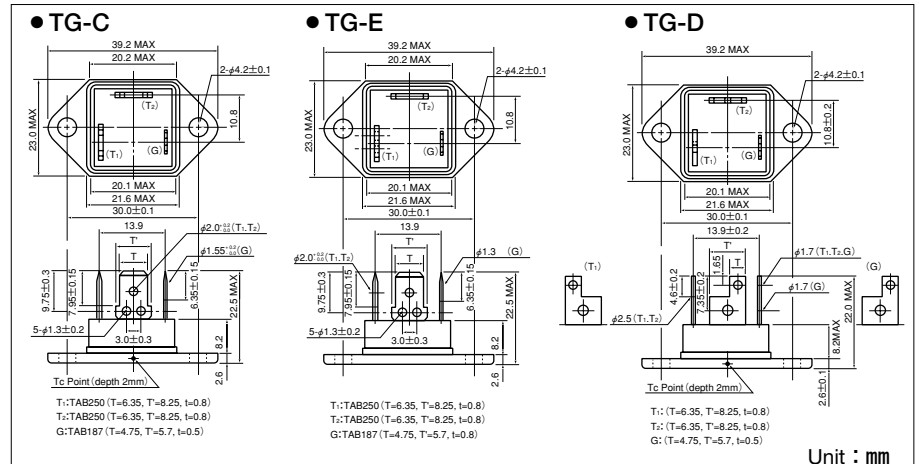
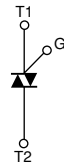

Maximum Ratings

($T_j=25^\circ\text{C}$ unless otherwise specified)

Symbol	Item	Ratings		Unit
		TG35C40	TG35C60	
V_{DRM}	Repetitive Peak Off-State Voltage	400	600	V

Symbol	Item	Conditions	Ratings	Unit
$I_{T(RMS)}$	R.M.S. On-State Current	$T_c=58^\circ\text{C}$	35	A
I_{TSM}	Surge On-State Current	One cycle, 50Hz/60Hz, peak, non-repetitive	300/330	A
I^2t	I^2t	Value for one cycle of surge current	450	A^2S
P_{GM}	Peak Gate Power Dissipation		10	W
$P_{G(AV)}$	Average Gate Power Dissipation		1	W
I_{GM}	Peak Gate Current		3	A
V_{GM}	Peak Gate Voltage		10	V
di/dt	Critical Rate of Rise of On-State Current	$I_G=100\text{mA}$, $T_j=25^\circ\text{C}$, $V_D=1/2V_{DRM}$, $dI_G/dt=1\text{A}/\mu\text{s}$	50	$\text{A}/\mu\text{s}$
T_j	Operating Junction Temperature		-25 to +125	$^\circ\text{C}$
T_{stg}	Storage Temperature		-40 to +125	$^\circ\text{C}$
V_{iso}	Isolation Breakdown Voltage (R.M.S.)	A.C.1 minute	2500	V
	Mounting Torque (M4)	Recommended Value 1.0-1.4 (10-14)	1.5 (15)	$\text{N}\cdot\text{m}$ ($\text{kgf}\cdot\text{cm}$)
	Mass	Typical value (Excluding bolt, nut and wrapping material)	23	g

Electrical Characteristics

Symbol	Item	Conditions	Ratings	Unit
I_{DRM}	Repetitive Peak Off-State Current, max	$V_D=V_{DRM}$, Single phase, half wave, $T_j=125^\circ\text{C}$	5	mA
V_{TM}	Peak On-State Voltage, max	On-State Current ($\sqrt{2} \times I_{T(RMS)}$), Inst. measurement	1.4	V
I_{GT1}^+	Gate Trigger Current, max	$T_j=25^\circ\text{C}$, $I_T=1\text{A}$, $V_D=6\text{V}$	50	mA
I_{GT1}^-		$T_j=25^\circ\text{C}$, $I_T=1\text{A}$, $V_D=6\text{V}$	50	
I_{GT3}^+			—	
I_{GT3}^-		$T_j=25^\circ\text{C}$, $I_T=1\text{A}$, $V_D=6\text{V}$	50	
V_{GT1}^+	Gate Trigger Voltage, max	$T_j=25^\circ\text{C}$, $I_T=1\text{A}$, $V_D=6\text{V}$	3	V
V_{GT1}^-		$T_j=25^\circ\text{C}$, $I_T=1\text{A}$, $V_D=6\text{V}$	3	
V_{GT3}^+			—	
V_{GT3}^-		$T_j=25^\circ\text{C}$, $I_T=1\text{A}$, $V_D=6\text{V}$	3	
V_{GD}	Non-Trigger Gate Voltage, min	$T_j=125^\circ\text{C}$, $V_D=1/2V_{DRM}$	0.2	V
t_{gt}	Turn On Time, max.	$I_{T(RMS)}$, $I_G=100\text{mA}$, $V_D=1/2V_{DRM}$, $T_j=25^\circ\text{C}$, $dI_G/dt=1\text{A}/\mu\text{s}$	10	V
dv/dt	Critical Rate of Rise on-State Voltage, min.	$T_j=125^\circ\text{C}$, $V_D=2/3V_{DRM}$, Exponential wave.	20	$\text{V}/\mu\text{s}$
$(dv/dt)_c$	Critical Rate of Rise off-State Voltage at commutation, min	$T_j=125^\circ\text{C}$, $V_D=2/3V_{DRM}$, $(di/dt)_c=15\text{A}/\text{ms}$	5	$\text{V}/\mu\text{s}$
I_H	Holding Current, typ.	$T_j=25^\circ\text{C}$	30	mA
$R_{th(j-c)}$	Thermal Impedance, max	Junction to case	1.5	$^\circ\text{C}/\text{W}$

