

2544

Data Sheet
29317.6T

QUAD DARLINGTON POWER DRIVER

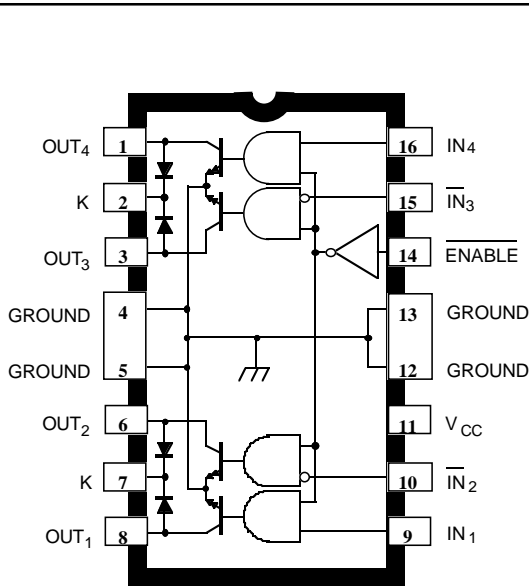

Dwg. PP-017A

Combining logic gates and high-current bipolar outputs, the UDN2544B quad Darlington power driver provides an interface between low-level logic circuitry and high-power loads. Each of the four outputs can sink up to 1.8 A in the on state with peak inrush currents to 2.5 A. The four power outputs are each comprised of an open-collector Darlington driver and an internal flyback/clamp diode for switching inductive loads. They feature a minimum breakdown and sustaining voltage of 50 V. The logic inputs are compatible with TTL and 5 V CMOS logic systems.

This device is particularly well-suited for unipolar stepper motor drive applications. With complementary control inputs and an active-low ENABLE, the UDN2544B makes it easy to implement full stepping of a stepper motor with only two microcontroller/microprocessor control lines. Other typical applications include relay or solenoid driving and incandescent or LED lamp driving.

The UDN2544B is supplied in a 16-pin batwing power DIP. The batwing construction provides for maximum package power dissipation in a standard DIP construction. At 25°C, and with only 1 sq. in. of copper foil at the ground tabs, the package is capable of safely dissipating 3.8 W.

FEATURES

- 1.8 A Continuous Output Current
- Output Voltage to 50 V
- Inputs Configured for Unipolar Stepper Motors
- Active-Low Output Enable
- TTL and 5 V CMOS Compatible Inputs
- Integral Transient-Suppression Diodes

ABSOLUTE MAXIMUM RATINGS at $T_A = 25^\circ\text{C}$

Output Voltage, V_{OUT}	50 V
Output Current, I_{OUT}	
(Peak)	2.5 A
(Continuous)	1.8 A
Logic Supply Voltage, V_{CC}	7.0 V
Input Voltage, V_{IN}	7.0 V
Package Power Dissipation, P_D	See Graph
Operating Temperature Range, T_A	-20°C to +85°C
Storage Temperature Range, T_S	-55°C to +150°C

Always order by complete part number: **UDN2544B**.

2544 QUAD DARLINGTON POWER DRIVER

ELECTRICAL CHARACTERISTICS at $T_A = +25^\circ\text{C}$, $T_J \leq 150^\circ\text{C}$, $V_{CC} = 4.75\text{ V to } 5.25\text{ V}$.

Characteristic	Symbol	Test Conditions	Limits			Units
			Min.	Typ.	Max.	
Output Leakage Current	I_{CEX}	$V_{OUT} = 50\text{ V}$	—	<1.0	100	μA
Output Sustaining Voltage	$V_{CE(sus)}$	$I_{OUT} = 1.8\text{ A}$, $L = 3.0\text{ mH}$	50	—	—	V
Output Saturation Voltage	$V_{CE(SAT)}$	$I_{OUT} = 600\text{ mA}$	—	0.9	1.0	V
		$I_{OUT} = 1.0\text{ A}$	—	1.0	1.2	V
		$I_{OUT} = 1.8\text{ A}$	—	1.3	1.6	V
Input Voltage	Logic 1	$V_{IN(1)} \text{ or } V_{EN(1)}$	2.4	—	—	V
	Logic 0	$V_{IN(0)} \text{ or } V_{EN(0)}$	—	—	0.8	V
Input Current	Logic 1	$V_{IN(1)} \text{ or } V_{EN(1)} = 2.4\text{ V}$	—	—	10	μA
	Logic 0	$V_{IN(0)} \text{ or } V_{EN(0)} = 0.8\text{ V}$	—	—	-100	μA
Total Supply Current	I_{CC}	All Outputs ON, Outputs Open	—	14	20	mA
		All Outputs OFF	—	0.4	2.0	mA
Clamp Diode Forward Voltage	V_F	$I_F = 1.0\text{ A}$	—	1.3	1.6	V
		$I_F = 1.8\text{ A}$	—	1.6	2.0	V
Clamp Diode Leakage Current	I_R	$V_R = 50\text{ V}$	—	< 1.0	100	μA

Typical Data is for design information only.

Negative current is defined as coming out of (sourcing) the specified terminal.

As used here, -100 is defined as greater than +10 (absolute magnitude convention) and the minimum is implicitly zero.

TRUTH TABLE

ENABLE	IN ₁	OUT ₁	IN ₂	OUT ₂	IN ₃	OUT ₃	IN ₄	OUT ₄
L	H	ON	H	OFF	H	OFF	H	ON
	L	OFF	L	ON	L	ON	L	OFF
H	X	OFF	X	OFF	X	OFF	X	OFF

X = Don't care

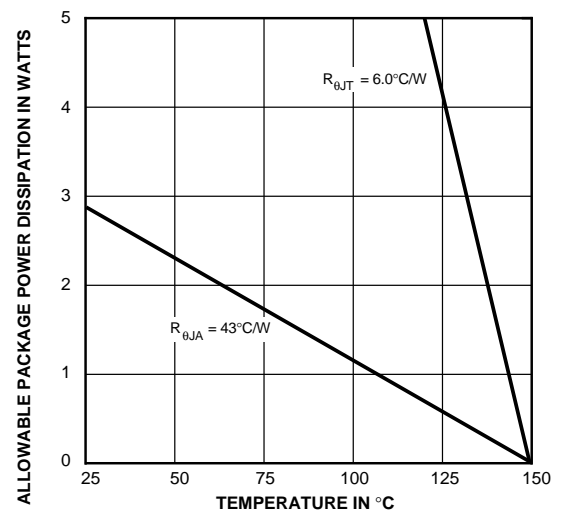

Dwg. GP-010B



2544 QUAD DARLINGTON POWER DRIVER

TYPICAL APPLICATION (UNIPOLAR STEPPER MOTOR WITH ZENER FLYBACK)

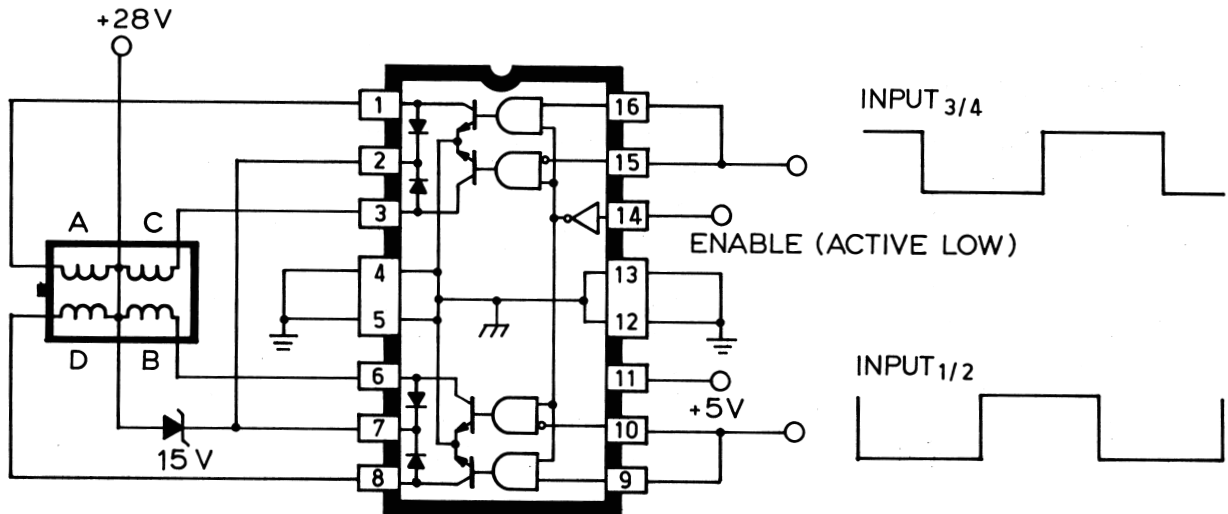

Dwg. EP-015

TRUTH TABLE

INPUTS		WINDINGS			
1/2	3/4	A	B	C	D
L	H	ON	ON	OFF	OFF
L	L	OFF	ON	ON	OFF
H	L	OFF	OFF	ON	ON
H	H	ON	OFF	OFF	ON

APPLICATIONS INFORMATION

A typical application is shown driving a four-phase unipolar stepper motor. Note that with the complimentary control inputs, only two logic signals are needed to drive the motor in the two-phase format. The two phase drive format illustrated, energizes two adjacent phases in each detent position (AB, BC, CD, DA) to provide an improved torque-speed product and greater detent torque.

A Zener diode can be used to increase the flyback voltage. The increased flyback voltage gives a much faster inductive load turn-OFF current decay resulting in improved motor performance. The maximum Zener voltage, plus the load supply voltage, plus the flyback diode forward voltage must not exceed the device's rated sustaining voltage.

With external control circuitry, the ENABLE input (active low) can be used for chopper (PWM) applications. If the ENABLE input is not used, it should be tied low.

All inputs will float high if open circuited.

Allegro MicroSystems, Inc. reserves the right to make, from time to time, such departures from the detail specifications as may be required to permit improvements in the design of its products.

The information included herein is believed to be accurate and reliable. However, Allegro MicroSystems, Inc. assumes no responsibility for its use; nor for any infringements of patents or other rights of third parties which may result from its use.

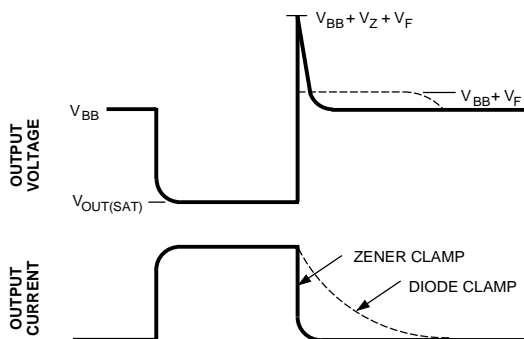

Dwg. WP-001

2544 QUAD DARLINGTON POWER DRIVER

Dimensions in Inches (controlling dimensions)

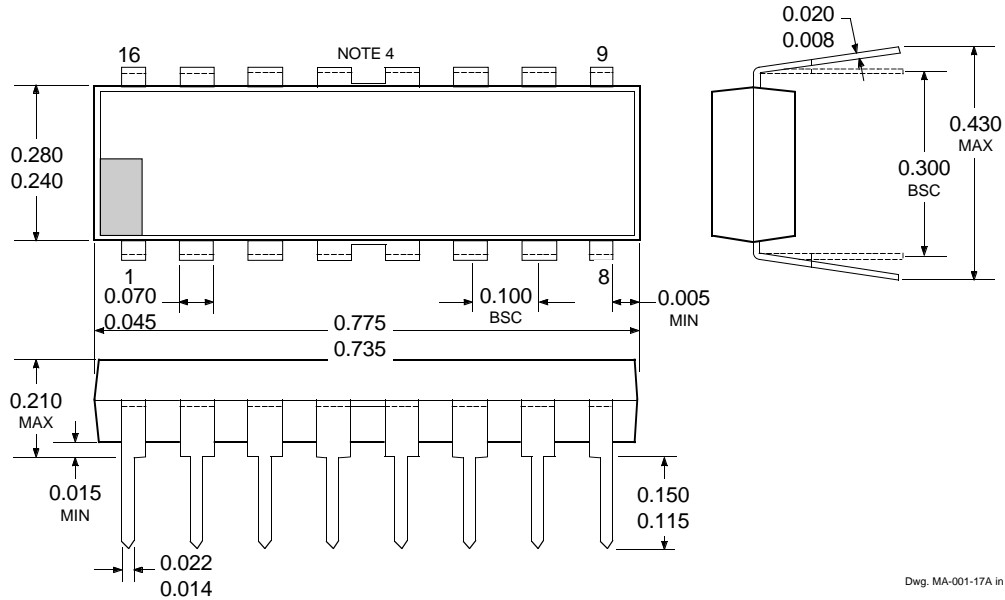

Dimensions in Millimeters (for reference only)

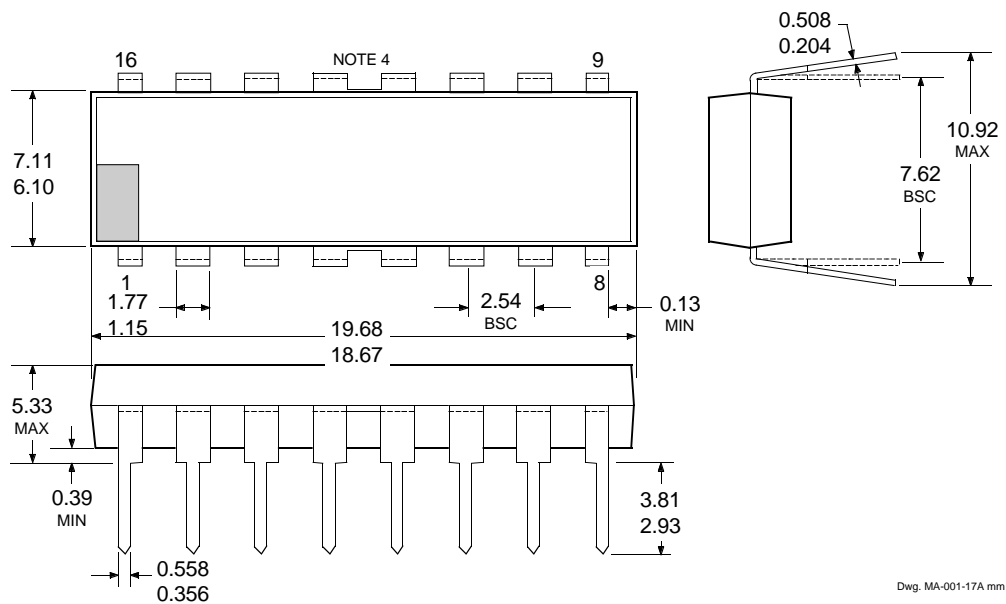

- NOTES: 1. Leads 1, 8, 9, and 16 may be half leads at vendor's option.
 2. Lead thickness is measured at seating plane or below.
 3. Lead spacing tolerance is non-cumulative.
 4. Webbed lead frame. Leads indicated are internally one piece.
 5. Exact body and lead configuration at vendor's option within limits shown.