

2596 AND 2597

8-CHANNEL SATURATED SINK DRIVERS

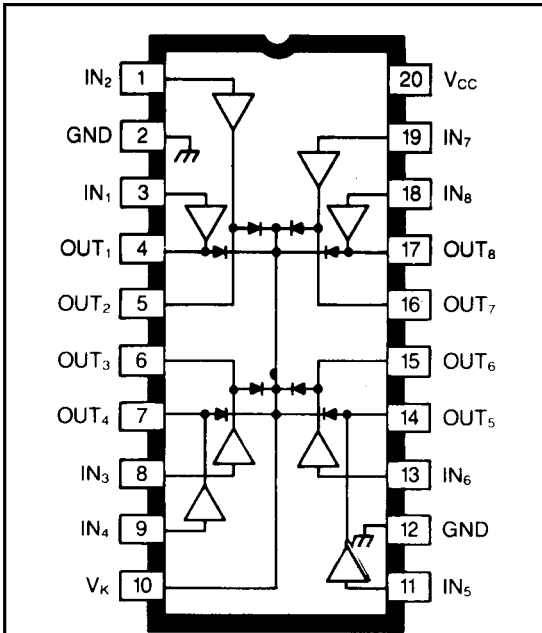

Dwg. No. W-100

ABSOLUTE MAXIMUM RATINGS at $T_A = +25^\circ\text{C}$

Output Voltage, V_{CE}	50 V
Output Current, I_{OUT}	
(UDN2596A)	500 mA
(UDN2597A)	1.0 A
Supply Voltage, V_{CC}	7.0 V
Input Voltage, V_{IN}	7.0 V
Package Power Dissipation,	
P_D	2.27 W*
Operating Temperature Range,	
T_A	-20°C to +85°C
Storage Temperature Range,	
T_S	-65°C to +150°C
*Derate at the rate of 18.2 mW/°C above $T_A = +25^\circ\text{C}$	

Low output-saturation voltages at high load currents are provided by UDN2596A and UDN2597A sink driver ICs. These devices can be used as interface buffers between standard low-power digital logic (particularly MOS) and high-power loads such as relays, solenoids, stepping motors, and LED or incandescent displays. The eight saturated sink drivers in each device feature high-voltage, high-current open-collector outputs. Transient suppression clamp diodes and a minimum 35 V output sustaining voltage allow their use with many inductive loads.

The saturated (non-Darlington) NPN outputs provide low collector-emitter voltage drops as well as improved turn-off times due to an active pull-down function within the output predrive section. The UDN2596A is for use with output loads to 500 mA while the UDN2597A is for use with loads to 1 A. Adjacent outputs may be paralleled for higher load currents.

Inputs require very low input current and are activated by a low logic level consistent with the much greater sinking capability associated with NMOS, CMOS, and TTL logic. The UDN2596A and UDN2597A are rated for use with 5 V logic levels.

Both devices are furnished in 20-pin DIP packages with copper leadframes for improved thermal characteristics. The UDN2596A is also available for operation between -40°C and +85°C. To order, change the prefix from 'UDN' to 'UDQ'.

FEATURES

- Non-Inverting Function
- Low Output ON Voltages
- Up to 1.0 A Sink Capability
- 50 V Min. Output Breakdown
- Output Transient-Suppression Diodes
- Output Pull-Down for Fast Turn-Off
- TTL, CMOS Compatible Inputs
- Automotive Capable

ONE OF EIGHT DRIVERS

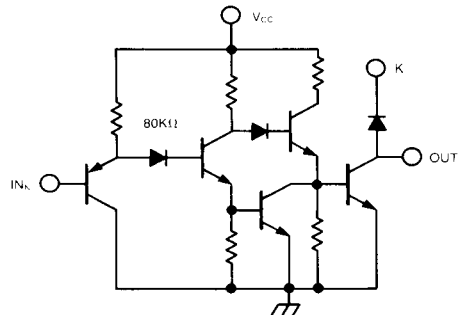

Dwg. No. W-101

2596 AND 2597
8-CHANNEL
SATURATED SINK DRIVERS

ELECTRICAL CHARACTERISTICS at $T_A = +25^\circ\text{C}$, $V_{CC} = 5.0\text{ V}$

Characteristics	Symbol	Applicable Devices	Test Conditions	Limits		
				Min.	Max.	Units
Output Leakage Current	I_{CEX}	Both	$V_{OUT} = 50\text{ V}$, $V_{IN} = 2.4\text{ V}$	—	10	μA
Output Sustaining Voltage	$V_{CE(sus)}$	UDN2596A	$I_{OUT} = 300\text{ mA}$, $L = 2\text{ mH}$	35	—	V
		UDN2597A	$I_{OUT} = 750\text{ mA}$, $L = 2\text{ mH}$	35	—	V
Output Saturation Voltage	$V_{CE(SAT)}$	UDN2596A	$I_{OUT} = 300\text{ mA}$	—	0.5	V
		UDN2597A	$I_{OUT} = 750\text{ mA}$	—	1.0	V
Clamp Diode Leakage Current	I_R	Both	$V_R = 50\text{ V}$	—	10	μA
Clamp Diode Forward Voltage	V_F	UDN2596A	$I_F = 300\text{ mA}$	—	1.8	V
		UDN2597A	$I_F = 750\text{ mA}$	—	1.8	V
Logic Input Current	$I_{IN(0)}$	UDN2596A	$V_{IN} = 0.8\text{ V}$	—	-15	μA
		UDN2597A	$V_{IN} = 0.8\text{ V}$	—	-50	μA
	$I_{IN(1)}$	Both	$V_{IN} = 2.4\text{ V}$	—	10	μA
Supply Current	$I_{CC(ON)}$	UDN2596A	any one driver $V_{IN} = 0.8\text{ V}$	—	6.0	mA
		UDN2597A	any one driver $V_{IN} = 0.8\text{ V}$	—	31	mA
	$I_{CC(OFF)}$	UDN2596A	all drivers $V_{IN} = 2.4\text{ V}$	0.75	1.3	mA
		UDN2597A	all drivers $V_{IN} = 2.4\text{ V}$	0.75	15	mA
Turn-On Delay	t_{pd0}	Both	$0.5 E_{IN}$ to $0.5 E_{OUT}$	—	3.0	μs
Turn-Off Delay	t_{pd1}	Both	$0.5 E_{IN}$ to $0.5 E_{OUT}$	—	2.0	μs

TYPICAL APPLICATION
DUAL STEPPER MOTOR DRIVE

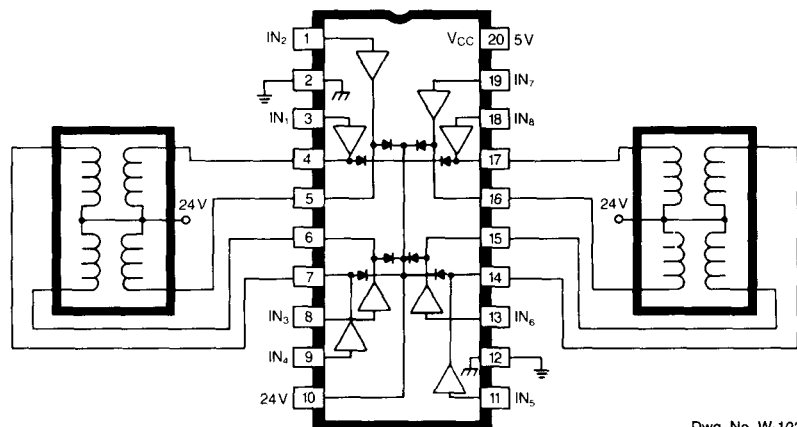

Dwg. No. W-102A

RECOMMENDED
OPERATING CONDITIONS

Type Number	Logic	I_{OUT}
UDN2596A	5.0 V	300 mA
UDN2597A	5.0 V	750 mA

Note: Pins 2 and 12 must both be connected to power ground.

2596 AND 2597
8-CHANNEL
SATURATED SINK DRIVERS

Dimensions in Inches
 (controlling dimensions)

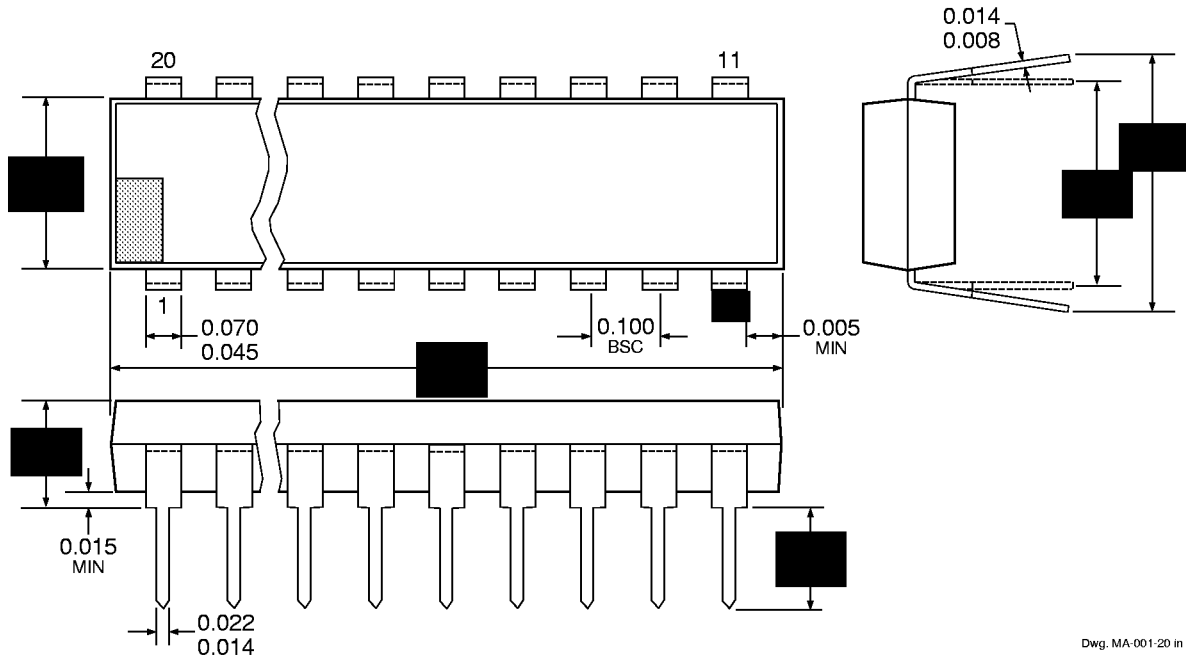

Dwg. MA-001-20 in

Dimensions in Millimeters
 (for reference only)

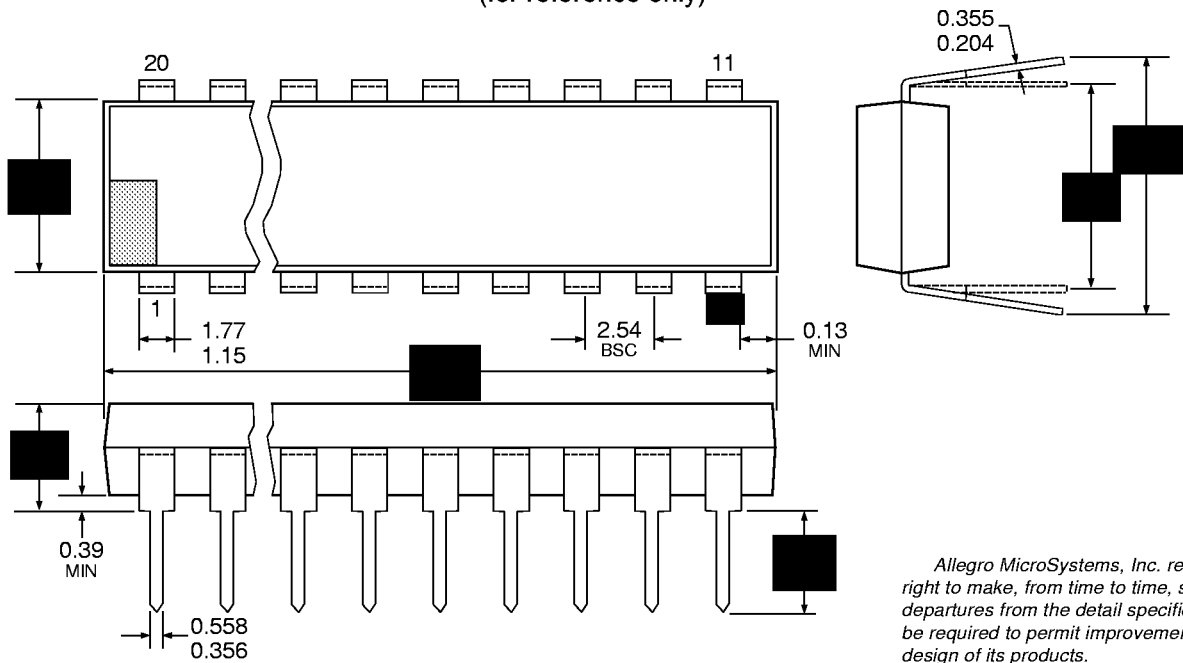

- NOTES: 1. Exact body and lead configuration at vendor's option within limits shown.
 2. Lead spacing tolerance is non-cumulative.
 3. Lead thickness is measured at seating plane or below.

Allegro MicroSystems, Inc. reserves the right to make, from time to time, such departures from the detail specifications as may be required to permit improvements in the design of its products.

The information included herein is believed to be accurate and reliable. However, Allegro MicroSystems, Inc. assumes no responsibility for its use; nor for any infringements of patents or other rights of third parties which may result from its use.