

BIPOLAR ANALOG INTEGRATED CIRCUIT

μ PC4062

DUAL J-FET INPUT LOW-POWER OPERATIONAL AMPLIFIER

DESCRIPTION

The μ PC4062 is a low-power, J-FET input, operational amplifier featuring low supply voltage operation from ± 2 V. Supply current of μ PC4062 is 1/10 the supply current of a μ PC4082 op-amp. With very low input bias current characteristics, the μ PC4062 is an excellent choice for hand-held measurement equipment and other low-power application circuits.

FEATURES

- Low supply current: 400 μ A (TYP.)
- Very low input bias and offset currents
- High input impedance...J-FET Input Stage
- Low supply voltage operation
- Output short circuit protection
- Internal frequency compensation

EQUIVALENT CIRCUIT (1/2 Circuit)

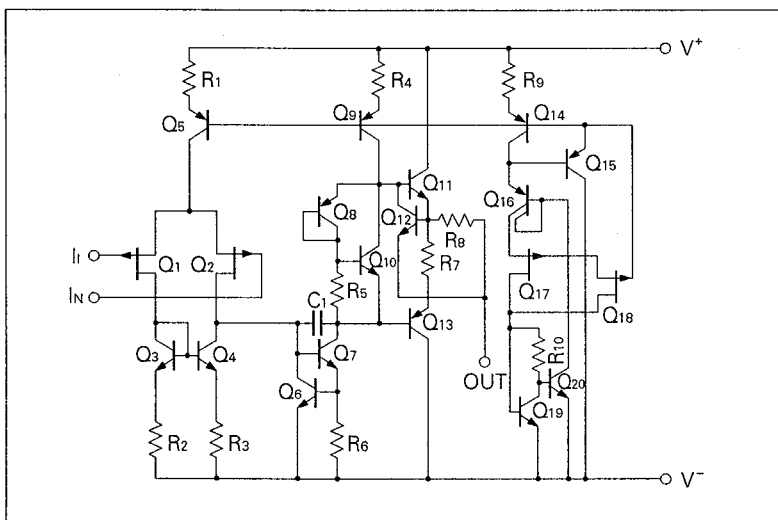

CONNECTION DIAGRAM (Top View)

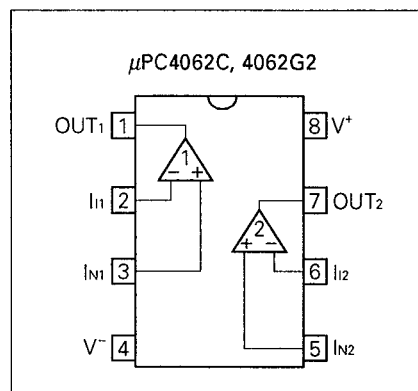

ORDERING INFORMATION

PART NUMBER	PACKAGE	QUALITY GRADE
μ PC4062C	8 PIN PLASTIC DIP (300 mil)	Standard
μ PC4062G2	8 PIN PLASTIC SOP (225 mil)	Standard

Please refer to "Quality grade on NEC Semiconductor Devices" (Document number IEI-1209) published by NEC Corporation to know the specifications of quality grade on the devices and its recommended applications.

ABSOLUTE MAXIMUM RATINGS (T_a = 25 °C)

PARAMETER		SYMBOL	μPC4062	UNIT
Voltage between V ⁺ and V ⁻ (Note 1)		V ⁺ - V ⁻	-0.3 to +36	V
Differential Input Voltage		V _{ID}	±30	V
Input Voltage (Note 2)		V _I	V ⁻ -0.3 to V ⁺ +0.3	V
Output Voltage (Note 3)		V _O	V ⁻ -0.3 to V ⁺ +0.3	V
Power Dissipation	C Package (Note 4)	P _T	350	mW
	G2 Package (Note 5)		440	mW
Output Short Circuit Duration (Note 6)			Indefinite	sec
Operating Temperature Range		T _{opt}	-20 to +80	°C
Storage Temperature Range		T _{stg}	-55 to +125	°C

Note 1. Reverse connection of supply voltage can cause destruction.

Note 2. The input voltage should be allowed to input without damage or destruction. Even during the transition period of supply voltage, power on/off etc., this specification should be kept. The normal operation will establish when the both inputs are within the Common Mode Input Voltage Range of electrical characteristics.

Note 3. This specification is the voltage which should be allowed to supply to the output terminal from external without damage or destructive. Even during the transition period of supply voltage, power on/off etc., this specification should be kept. The output voltage of normal operation will be the Output Voltage Swing of electrical characteristics.

Note 4. Thermal derating factor is -5.0 mW / °C when ambient temperature is higher than 55 °C.

Note 5. Thermal derating factor is -4.4 mW / °C when ambient temperature is higher than 25 °C.

Note 6. Pay careful attention to the total power dissipation not to exceed the absolute maximum ratings, Note 4 and Note 5.

RECOMMENDED OPERATING CONDITIONS

CHARACTERISTIC	SYMBOL	MIN.	TYP.	MAX.	UNIT
Supply Voltage	V [±]	± 2		± 16	V
Output Current (SOURCE)	I _{O SOURCE}			5	mA
Output Current (SINK)	I _{O SINK}			3.5	mA
Capacitive Load (A _v = +1)	C _L			100	pF

ELECTRICAL CHARACTERISTICS (T_a = 25 °C, V[±] = ±15 V)

CHARACTERISTIC	SYMBOL	MIN.	TYP.	MAX.	UNIT	CONDITION
Input Offset Voltage	V _{io}		±2	±10	mV	R _s ≤ 50 Ω
Input Offset Current (Note 7)	I _{io}		±5	±50	pA	
Input Bias Current (Note 7)	I _B		10	100	pA	
Large Signal Voltage Gain	A _v	3	9		V/mV	R _L ≥ 10 kΩ, V _o = ±10 V
Supply Current	I _{cc}		400	500	μA	I _o = 0 A, Both Amplifiers
Common Mode Rejection Ratio	CMR	70	90		dB	
Supply Voltage Rejection Ratio	SVR	70	90		dB	
Output Voltage Swing	V _{om}	±12	+14.0 -13.6		V	R _L ≥ 10 kΩ
Common Model Input Voltage Range	V _{icm}	±12	+15 -13		V	
Slew Rate	SR		3		V/μs	A _v = 1
Unity Gain Frequency	f _{unity}		1		MHz	
Input Equivalent Noise Voltage Density	e _n		30		nV/√Hz	R _s = 100 Ω, f = 1 kHz
Channel Separation			120		dB	
Input Offset Voltage	V _{io}			±15	mV	R _s ≤ 50 Ω, T _a = -20 to +70 °C
Average V _{io} Temperature Drift	ΔV _{io} /ΔT		±10		μV/°C	T _a = -20 to +70 °C
Input Offset Current (Note 7)	I _{io}			±2	nA	T _a = -20 to +70 °C
Input Bias Current (Note 7)	I _B			3.5	nA	T _a = -20 to +70 °C

Note 7. Input bias currents flow into IC. Because each currents are gate leak current of P-channel J-FET on input stage.

And that are temperature sensitive. Short time measuring method is recommendable to maintain the junction temperature close to the ambient temperature.

TYPICAL PERFORMANCE CHARACTERISTICS ($T_a = 25\text{ }^\circ\text{C}$, TYP.)

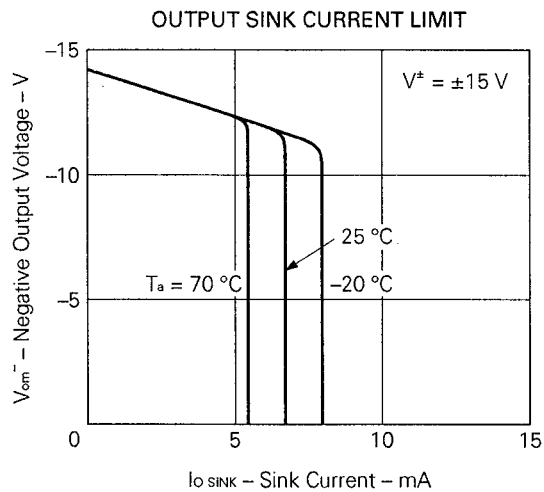
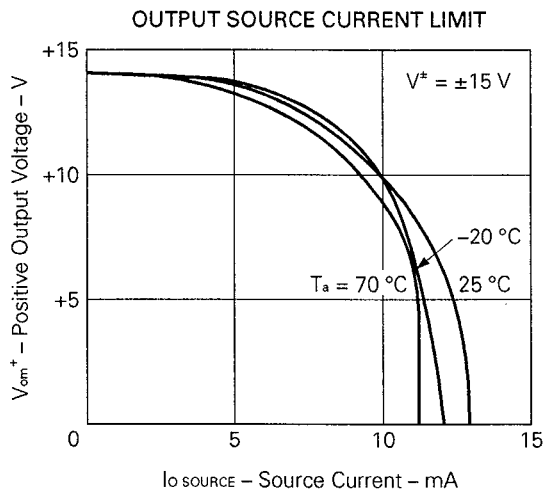
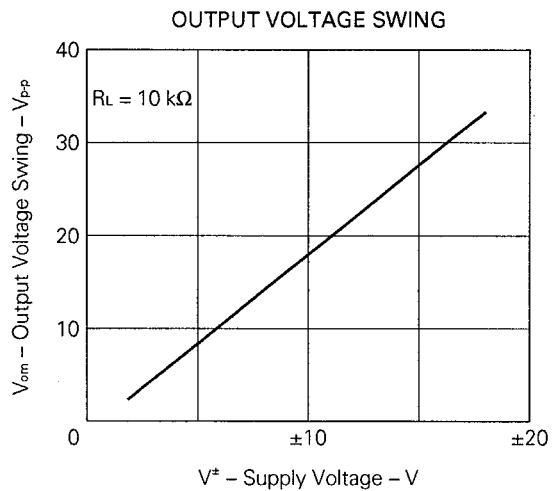
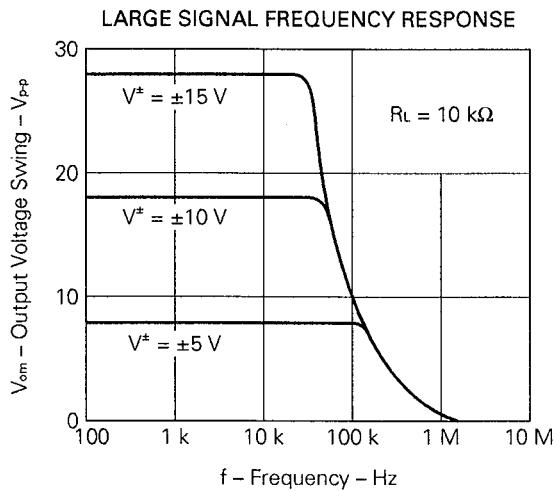
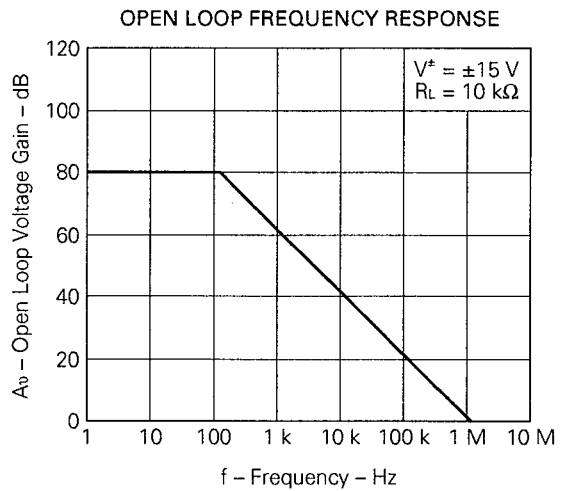
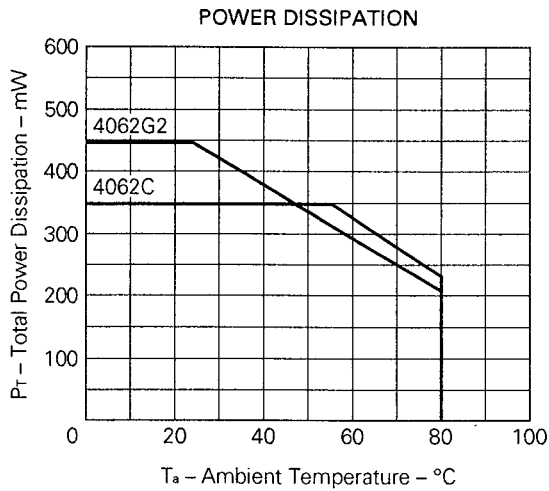

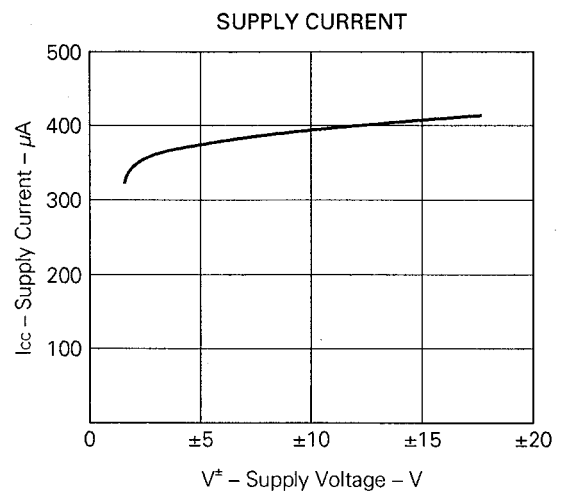
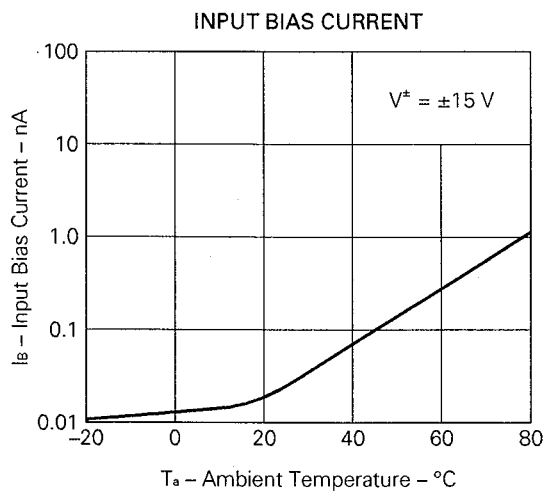
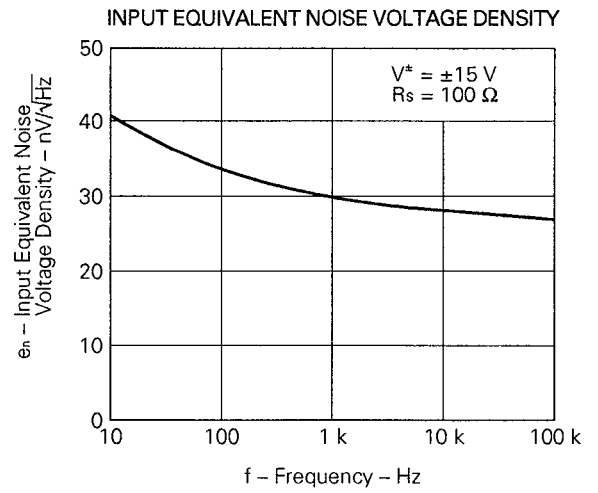
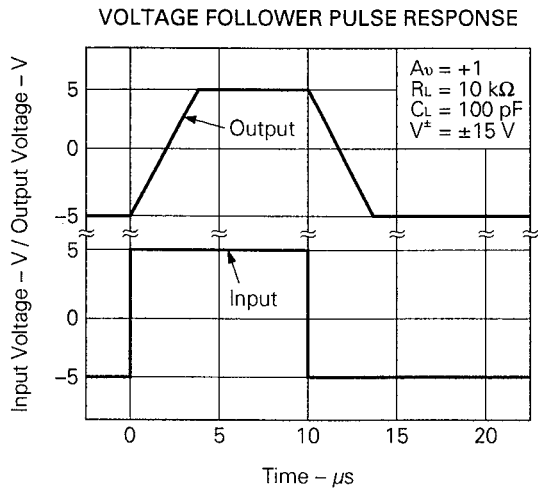

8PIN PLASTIC DIP (300 mil)

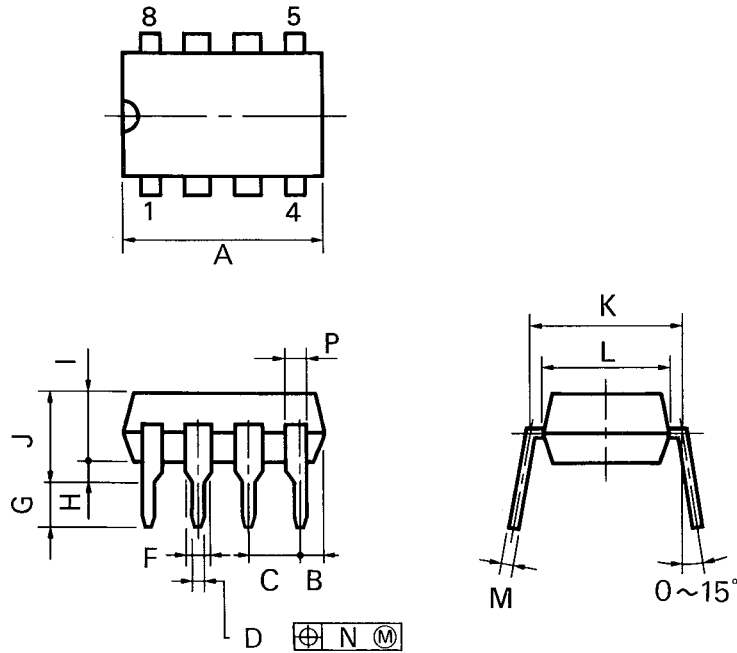

P8C-100-300B,C

NOTES

- 1) Each lead centerline is located within 0.25 mm (0.01 inch) of its true position (T.P.) at maximum material condition.
- 2) Item "K" to center of leads when formed parallel.

ITEM	MILLIMETERS	INCHES
A	10.16 MAX.	0.400 MAX.
B	1.27 MAX.	0.050 MAX.
C	2.54 (T.P.)	0.100 (T.P.)
D	0.50 ^{+0.10}	0.020 ^{+0.004} _{-0.005}
F	1.4 MIN.	0.055 MIN.
G	3.2 ^{+0.3}	0.126 ^{+0.012}
H	0.51 MIN.	0.020 MIN.
I	4.31 MAX.	0.170 MAX.
J	5.08 MAX.	0.200 MAX.
K	7.62 (T.P.)	0.300 (T.P.)
L	6.4	0.252
M	0.25 ^{+0.10} _{-0.05}	0.010 ^{+0.004} _{-0.003}
N	0.25	0.01
P	0.9 MIN.	0.035 MIN.

8 PIN PLASTIC SOP (225 mil)

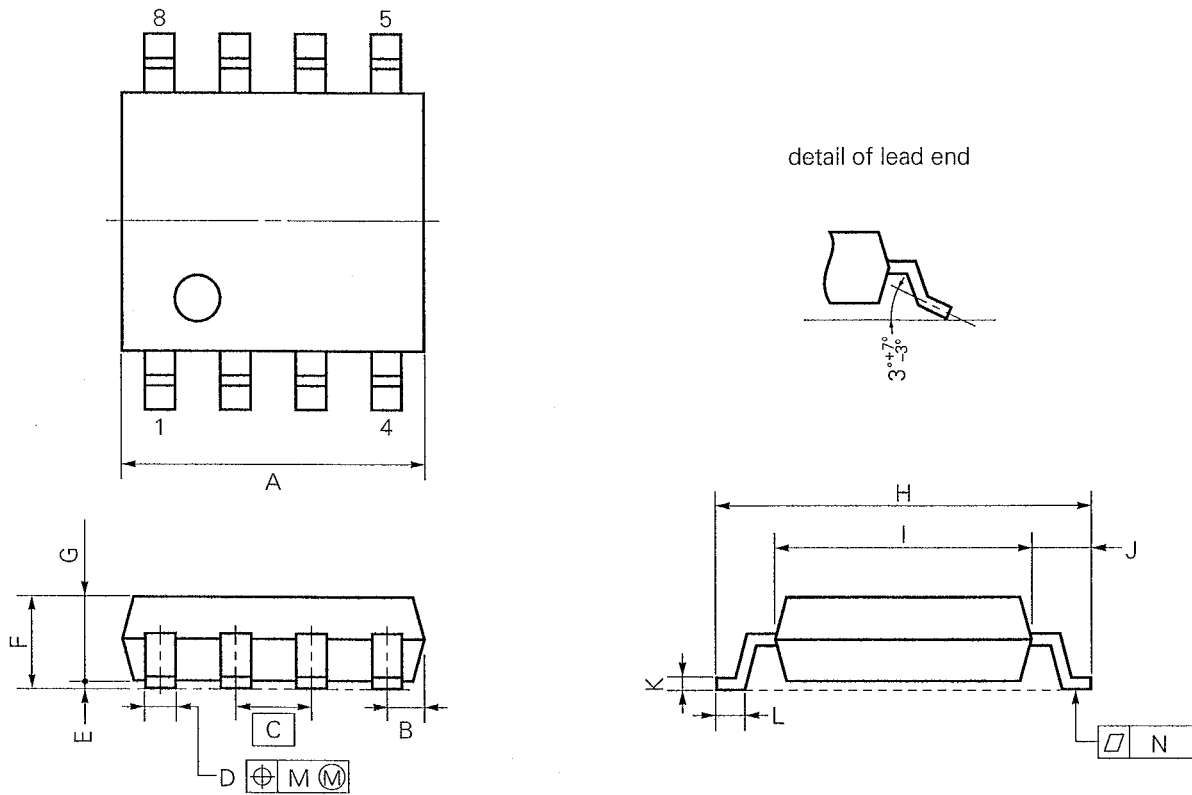

NOTE

Each lead centerline is located within 0.12 mm (0.005 inch) of its true position (T.P.) at maximum material condition.

S8GM-50-225B-2

ITEM	MILLIMETERS	INCHES
A	5.37 MAX.	0.212 MAX.
B	0.78 MAX.	0.031 MAX.
C	1.27 (T.P.)	0.050 (T.P.)
D	0.40 ^{+0.10} _{-0.05}	0.016 ^{+0.004} _{-0.003}
E	0.1±0.1	0.004±0.004
F	1.8 MAX.	0.071 MAX.
G	1.49	0.059
H	6.5±0.3	0.256±0.012
I	4.4	0.173
J	1.1	0.043
K	0.15 ^{+0.10} _{-0.05}	0.006 ^{+0.004} _{-0.002}
L	0.6±0.2	0.024 ^{+0.008} _{-0.009}
M	0.12	0.005
N	0.15	0.006

RECOMMENDED SOLDERING CONDITIONS

The following conditions (see table below) must be met when soldering this product.
Please consult with our sales offices in case other soldering process is used, or in case soldering is done under different conditions.

TYPES OF SURFACE MOUNT DEVICE

For more details, refer to our document "SEMICONDUCTOR DEVICE MOUNTING TECHNOLOGY MANUAL" (IEI-1207).

[μPC4062G2]

Soldering method	Soldering conditions	Recommended condition symbol
Infrared ray reflow	Peak package's surface temperature: 230 °C or below, Reflow time: 30 seconds or below (210 °C or higher), Number of reflow process: 1, Exposure limit*: None	IR30-00-1
VPS	Peak package's surface temperature: 215 °C or below, Reflow time: 40 seconds or below (200 °C or higher), Number of reflow process: 1, Exposure limit*: None	VP15-00-1
Wave soldering	Solder temperature: 260 °C or below, Flow time: 10 seconds or below Number of flow process: 1, Exposure limit*: None	WS15-00-1
Partial heating method	Terminal temperature: 300 °C or below, Flow time: 10 seconds or below, Exposure limit*: None	

*: Exposure limit before soldering after dry-pack package is opened.
Storage conditions: 25 °C and relative humidity at 65 % or less.

Note: Do not apply more than a single process at once, except for "Partial heating method."

TYPES OF THROUGH HOLE DEVICE

[μPC4062C]

Soldering method	Soldering conditions	Recommended condition symbol
Wave soldering	Solder temperature: 260 °C or below, Flow time: 10 seconds or below	