

QUAD HIGH SIDE SMART POWER SOLID STATE RELAY

TARGET DATA

TYPE	V _{demag} *	R _{DS(on)} *	I _{OUT} *	V _{CC}
VN330SP	V _{CC} -55V	0.2 Ω	1 A	36 V

* per Channel

- OUTPUT CURRENT (CONTINUOUS):
1A PER CHANNEL
- DIGITAL INPUTS WITH 30V MAX VOLTAGE
- SHORTED LOAD AND
OVERTEMPERATURE PROTECTIONS
- 1A (EACH CHANNEL) CURRENT LIMITER
- UNDER VOLTAGE SHUT DOWN
- OPEN DRAIN DIAGNOSTIC OUTPUT
- FAST DEMAGNETIZATION OF INDUCTIVE
LOADS

DESCRIPTION

The VN330SP is a monolithic device made using SGS-THOMSON Vertical Intelligent Power Technology, intended for driving four independent resistive or inductive loads with one side connected to ground.

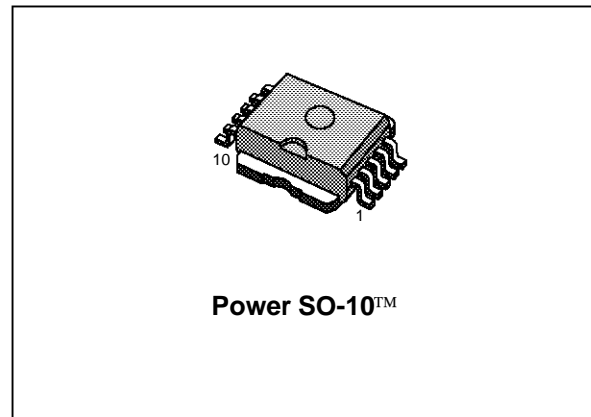

Active current limitation avoids dropping the system power supply in case of shorted load. Built-in thermal shut-down protects the chip from over temperature and short circuit. The open drain diagnostic output indicates short circuit and over temperature conditions.

BLOCK DIAGRAM

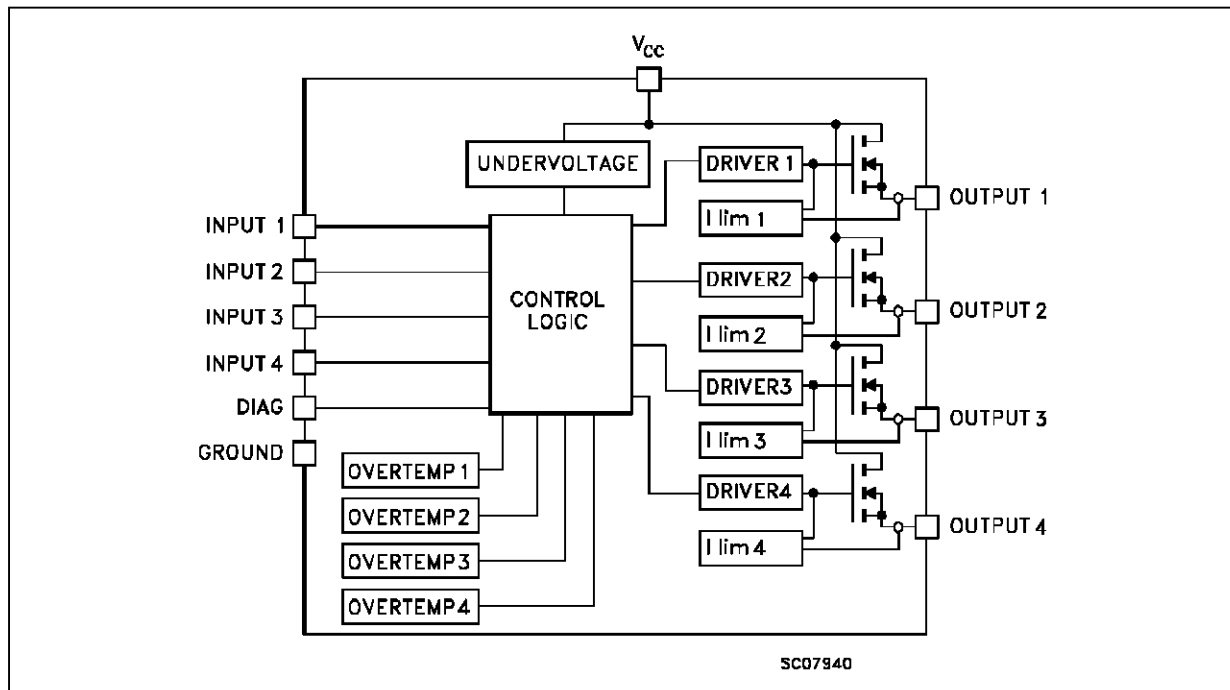

ABSOLUTE MAXIMUM RATING

Symbol	Parameter	Value	Unit
V_{CC}	Power Supply Voltage	45	V
$-V_{CC}$	Reverse Supply Voltage	-0.3	V
I_{OUT}	Output Current (cont.)	Internally Limited	A
I_R	Reverse Output Current (per channel)	-6	A
I_{IN}	Input Current (per channel)	± 10	mA
I_{DIAG}	DIAG Pin Current	± 10	mA
V_{ESD}	Electrostatic Discharge (1.5 k Ω , 100 pF)	2000	V
P_{tot}	Power Dissipation at $T_c \leq 25^\circ C$	Internally Limited	W
T_j	Junction Operating Temperature	Internally Limited	$^\circ C$
T_{stg}	Storage Temperature	-55 to 150	$^\circ C$

CONNECTION DIAGRAM

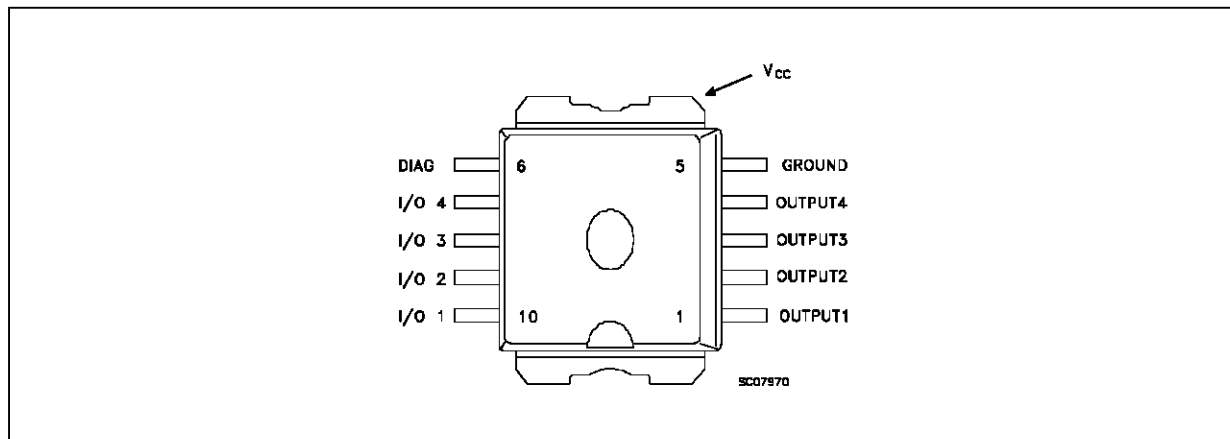

CURRENT AND VOLTAGE CONVENTIONS

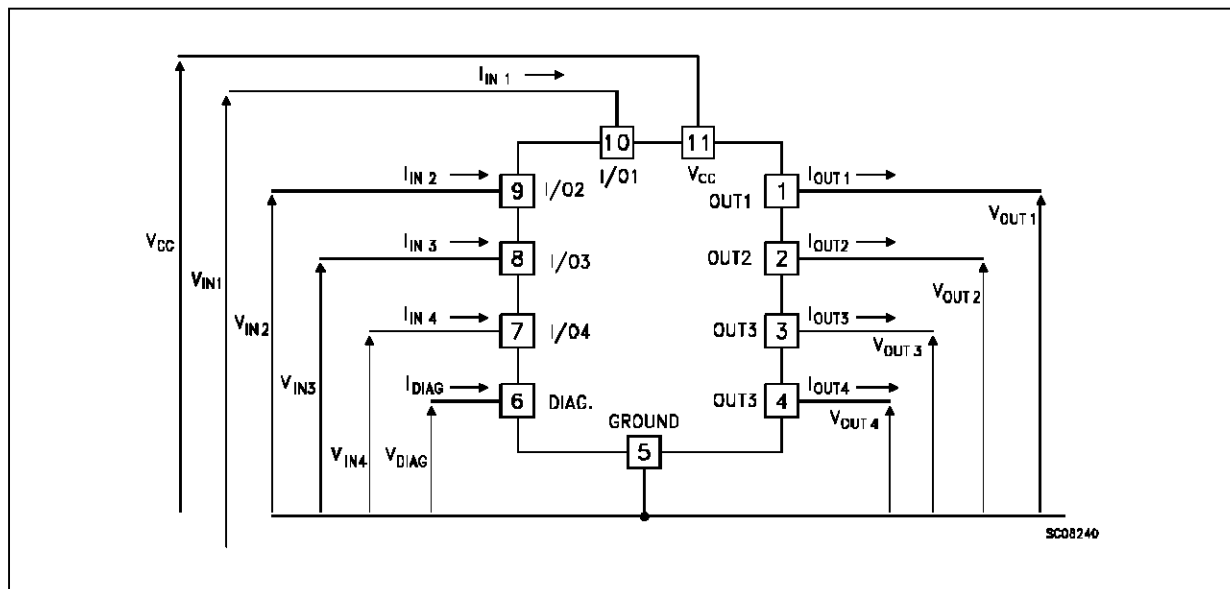

THERMAL DATA

$R_{thj-case}$	Thermal Resistance Junction-case (1)	Max	2	$^{\circ}C/W$
$R_{thj-amb}$	Thermal Resistance Junction-ambient (§)	Max	50	$^{\circ}C/W$

(1) All channels ON

(§) When mounted using minimum recommended pad size on FR-4 board

ELECTRICAL CHARACTERISTICS (V_{CC} 10 to 36 V; $-25 < T_{case} < 85^{\circ}C$ unless otherwise specified)

POWER

Symbol	Parameter	Test Conditions	Min.	Typ.	Max.	Unit
V_{CC}	Supply Voltage		10		36	V
R_{on}	On State Resistance	$I_{OUT} = 0.5 A$ $I_{OUT} = 0.5 A \quad T_j = 25^{\circ}C$			0.4 0.2	Ω Ω
I_s	Supply Current	All Channel Off On State ($T_c = 100^{\circ}C$) $I_{out1} \dots I_{out4} = 0$			1 10	mA mA
V_{demag}	Output Voltage at Turn-Off	$I_{out} = 0.5A \quad L_{LOAD} = 1 mH$	$V_{CC}-65$	$V_{CC}-55$	$V_{CC}-45$	V

SWITCHING

Symbol	Parameter	Test Conditions	Min.	Typ.	Max.	Unit
$t_{d(on)}$	Turn-on Delay Time Of Output Current	$I_{OUT} = 0.5 A$ Resistive Load Input Rise Time $< 0.1 \mu s \quad T_j = 25^{\circ}C$		10	20	μs
t_r	Rise Time Of Output Current	$I_{OUT} = 0.5 A$ Resistive Load Input Rise Time $< 0.1 \mu s \quad T_j = 25^{\circ}C$		15	45	μs
$t_{d(off)}$	Turn-off Delay Time Of Output Current	$I_{OUT} = 0.5 A$ Resistive Load Input Rise Time $< 0.1 \mu s \quad T_j = 25^{\circ}C$		15	30	μs
t_f	Fall Time Of Output Current	$I_{OUT} = 0.5 A$ Resistive Load Input Rise Time $< 0.1 \mu s \quad T_j = 25^{\circ}C$		6	15	μs
$(di/dt)_{on}$	Turn-on Current Slope	$I_{OUT} = 0.5 A$ $I_{OUT} = I_{lim} \quad 25 < T_j < 140^{\circ}C$			0.5 2	$A/\mu s$ $A/\mu s$
$(di/dt)_{off}$	Turn-off Current Slope	$I_{OUT} = 0.5 A$ $I_{OUT} = I_{li} \quad 25 < T_j < 140^{\circ}C$			2 4	$A/\mu s$ $A/\mu s$

LOGIC INPUT

Symbol	Parameter	Test Conditions	Min.	Typ.	Max.	Unit
V_{IL}	Input Low Level Voltage				2	V
V_{IH}	Input High Level Voltage		3.5			V
$V_{I(hyst.)}$	Input Hysteresis Voltage			0.5		V
I_{IN}	Input Current	$V_{IN} = 0$ to 30 V $V_{IN} = 0$ to 2 V	25		600	μA μA
V_{ICL}	Input Clamp Voltage	$I_{IN} = 1 mA$ $I_{IN} = -1 mA$	31	36 -0.7		V V

ELECTRICAL CHARACTERISTICS (continued)
PROTECTION AND DIAGNOSTICS

Symbol	Parameter	Test Conditions	Min.	Typ.	Max.	Unit
V _{STAT} (•)	Status Voltage Output Low	I _{STAT} = 5 mA (Fault Condition)			1	V
V _{SCL} (•)	Status Clamp Voltage	I _{STAT} = 1 mA I _{STAT} = -1 mA	31	36 -0.7		V V
V _{USD}	Under Voltage Shut Down		5		8	A
I _{LIM}	DC Short Circuit Current	V _{CC} = 24 V R _{LOAD} < 100 mΩ	0.7	1	1.5	A
t _{sc}	Switch-off Time in Short Circuit Condition at Start-Up				100	μs
I _{OVPK}	Peak Short Circuit Current				TBD	A
T _{TSD}	Thermal Shut-down Temperature		150	170		°C
T _R	Reset Temperature		135	155		°C

(*) The V_{IH} is internally clamped at 6V about. It is possible to connect this pin to an higher voltage via an external resistor calculated to not exceed 10 mA at the input pin.
 (•) Status determination > 100 μs after the switching edge.
 Note: If INPUTn pin is left floating the corresponding channel will automatically switch off. If GND pin is disconnected, all channels will switch off provided V_{CC} does not exceed 36V

Figure 1: SWITCHING PARAMETERS TEST CONDITIONS

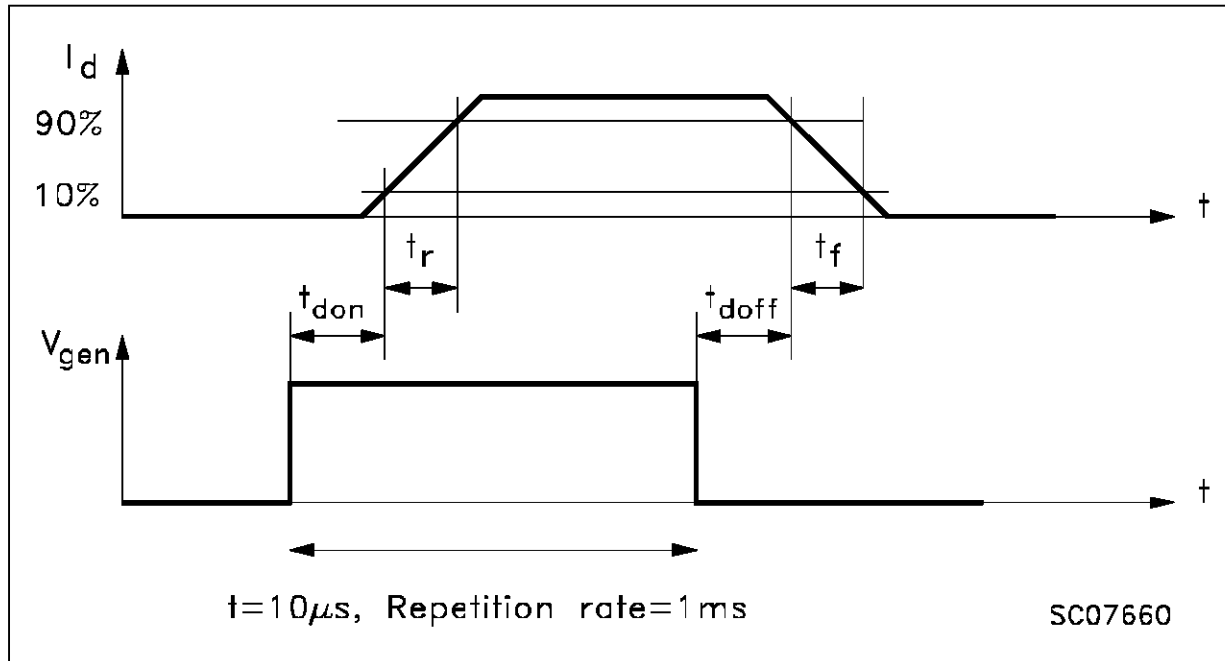

TRUTH TABLE

	INPUTn	OUTPUTn	DIAGNOSTIC
Normal Operation	L	L	H
	H	H	H
Over-temperature	L	L	H
	H	L	L
Under-voltage	L	L	H
	H	L	H
Shorted Load (current limitation)	L	L	H
	H	H	H

Figure 1: Waveforms

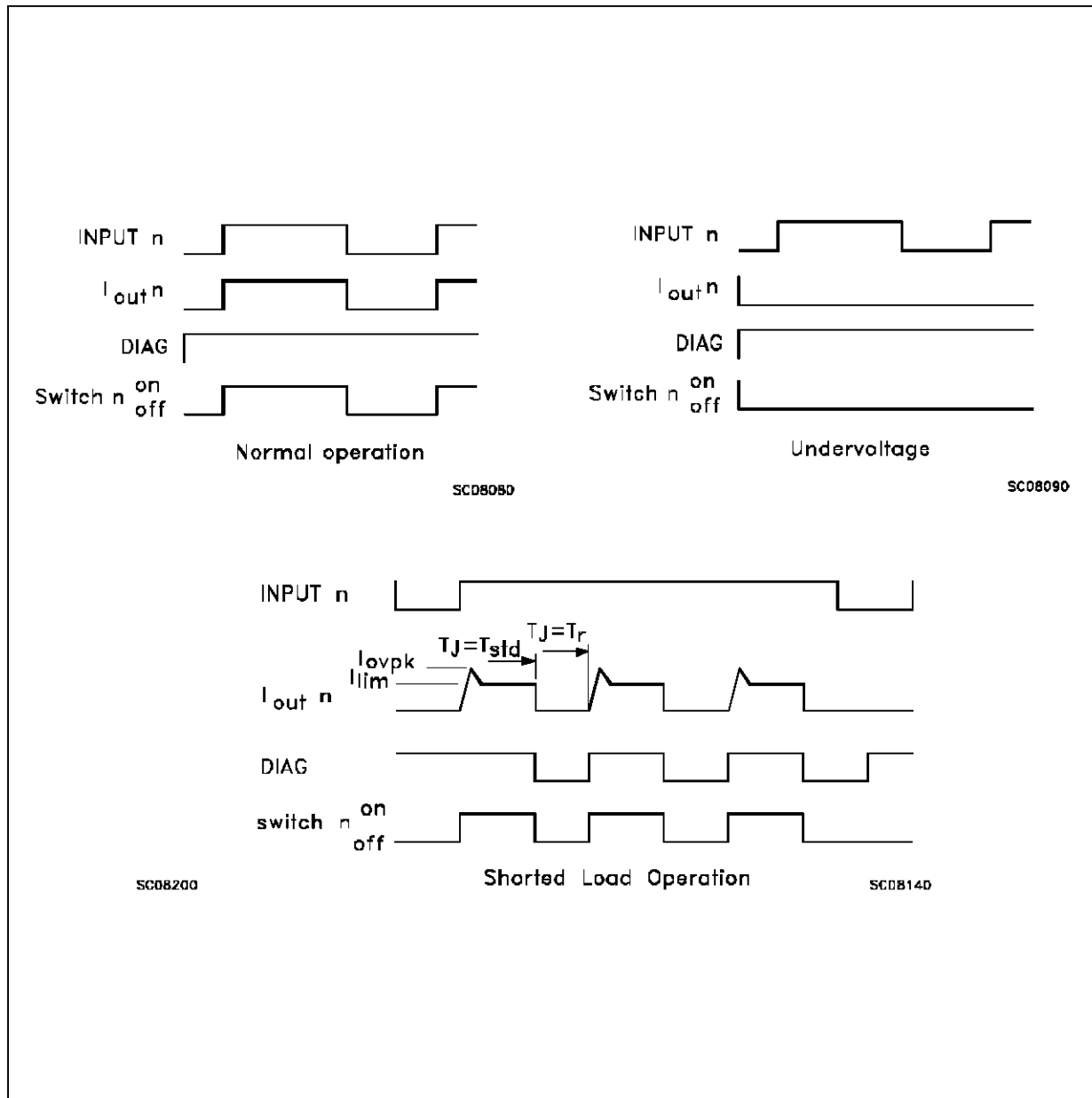

Power SO-10 MECHANICAL DATA

DIM.	mm			inch		
	MIN.	TYP.	MAX.	MIN.	TYP.	MAX.
A	3.45	3.5	3.55	0.135	0.137	0.140
B		1.28	1.30		0.050	0.051
C			0.15			0.006
D	9.40	9.50	9.60	0.370	0.374	0.378
E	4.98	5.08	5.48	0.196	0.200	0.216
E1	0.40	0.45	0.60	0.016	0.018	0.024
E2	1.17	1.27	1.37	0.046	0.050	0.054
F	9.30	9.40	9.50	0.366	0.370	0.374
F1	7.95	8.00	8.15	0.313	0.315	0.321
G	7.40	7.50	7.60	0.291	0.295	0.299
H	6.80	6.90	7.00	0.267	0.417	0.421
I		0.10			0.004	
K	13.80	14.10	14.40	0.543	0.555	0.567
L		0.40	0.50		0.016	0.020
M	1.60	1.67	1.80	0.063	0.066	0.071
N	0.60	0.08	1.00	0.024	0.031	0.039

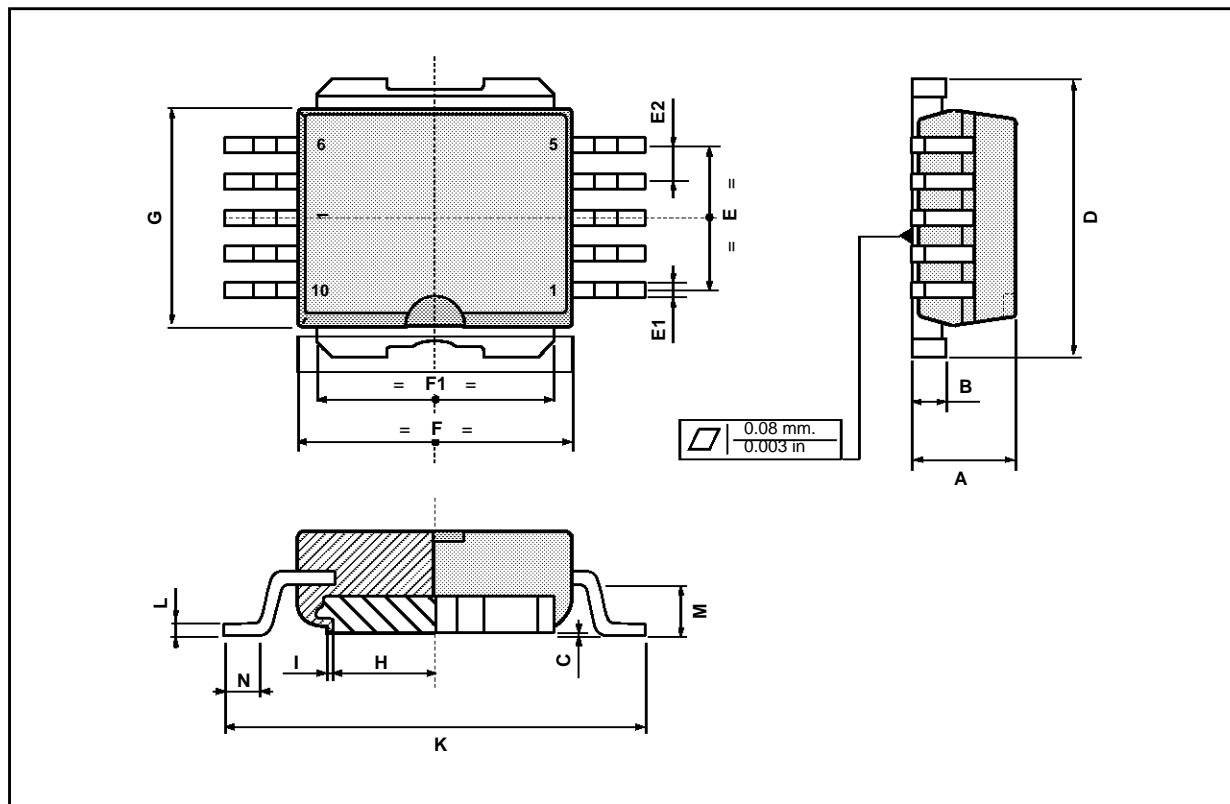

Information furnished is believed to be accurate and reliable. However, SGS-THOMSON Microelectronics assumes no responsibility for the consequences of use of such information nor for any infringement of patents or other rights of third parties which may result from its use. No license is granted by implication or otherwise under any patent or patent rights of SGS-THOMSON Microelectronics. Specifications mentioned in this publication are subject to change without notice. This publication supersedes and replaces all information previously supplied. SGS-THOMSON Microelectronics products are not authorized for use as critical components in life support devices or systems without express written approval of SGS-THOMSON Microelectronics.

© 1994 SGS-THOMSON Microelectronics - All Rights Reserved

SGS-THOMSON Microelectronics GROUP OF COMPANIES

Australia - Brazil - France - Germany - Hong Kong - Italy - Japan - Korea - Malaysia - Malta - Morocco - The Netherlands -
Singapore - Spain - Sweden - Switzerland - Taiwan - Thailand - United Kingdom - U.S.A