

1MBI200NH-060

IGBT Module

600V / 200A Chopper Module

■ Features

- High speed switching
- Low inductance module structure
- Suitable for Chopper and Dynamic brake circuit

■ Applications

- Uninterruptible power supply
- Inverter for Motor drive



■ Maximum ratings and characteristics

● Absolute maximum ratings (at Tc=25°C unless otherwise specified)

Item		Symbol	Rating	Unit	
IGBT	Collector-Emmitter voltage	V _{CEs}	600	V	
	Gate-Emmitter voltage	V _{GEs}	±20	V	
	Collector current	Continuous	I _c	200	A
		1ms	I _{c pulse}	400	A
Max. power dissipation	P _c	780	W		
FWD	Repetitive peak dissipation	V _{RRM}	600	V	
	Forward current	I _F	200	A	
		1ms	I _{F pulse}	400	A
Operating temperature	T _j	+150	°C		
Storage temperature	T _{stg}	-40 to +125	°C		
Isolation voltage	V _{is}	AC 2500 (1min.)	V		
Screw torque	Mounting *1	3.5	N·m		
	Terminals *1	3.5	N·m		

*1 : Recommendable value : 2.5 to 3.5 N·m (M5)

■ Equivalent Circuit Schematic

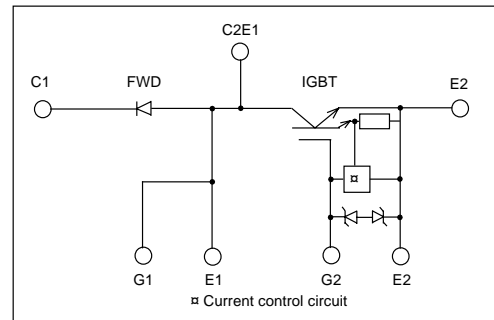

● Electrical characteristics (at Tj=25°C unless otherwise specified)

Item	Symbol	Characteristics			Conditions	Unit	
		Min.	Typ.	Max.			
IGBT	Zero gate voltage collector current	I _{CEs}	-	-	2.0	V _{GE} =0V, V _{CE} =600V	mA
	Gate-Emmitter leakage current	I _{GES}	-	-	30	V _{CE} =0V, V _{GE} =±20V	μA
	Gate-Emmitter threshold voltage	V _{GE(th)}	4.5	-	7.5	V _{CE} =20V, I _c =200mA	V
	Collector-Emmitter saturation voltage	V _{CE(sat)}	-	-	2.8	V _{GE} =15V, I _c =200A	V
	Input capacitance	C _{ies}	-	13200	-	V _{GE} =0V	pF
	Output capacitance	C _{oes}	-	2930	-	V _{CE} =10V	
	Reverse transfer capacitance	C _{res}	-	1330	-	f=1MHz	
	Turn-on time	t _{on}	-	0.6	1.2	V _{CC} =300V	μs
			-	0.2	0.6	I _c =200A	
		Turn-off time	t _{off}	-	0.6	1.0	
	t _f	-	0.2	0.35	R _G =9.1ohm		
FWD	Diode forward on voltage	V _F	-	-	3.0	I _F =200A, V _{GE} =0V	V
	Reverse recovery time	t _{rr}	-	-	0.3	I _F =200A	μs
	Reverse current	I _{RRM}	-	-	2.0	V _R =600V	mA

● Thermal resistance characteristics

Item	Symbol	Characteristics			Conditions	Unit
		Min.	Typ.	Max.		
Thermal resistance	R _{th(j-c)}	-	-	0.16	IGBT	°C/W
	R _{th(j-c)}	-	-	0.35	FWD	°C/W
	R _{th(c-f)*2}	-	0.025	-	the base to cooling fin	°C/W

*2 : This is the value which is defined mounting on the additional cooling fin with thermal compound

■ Characteristics (Representative)

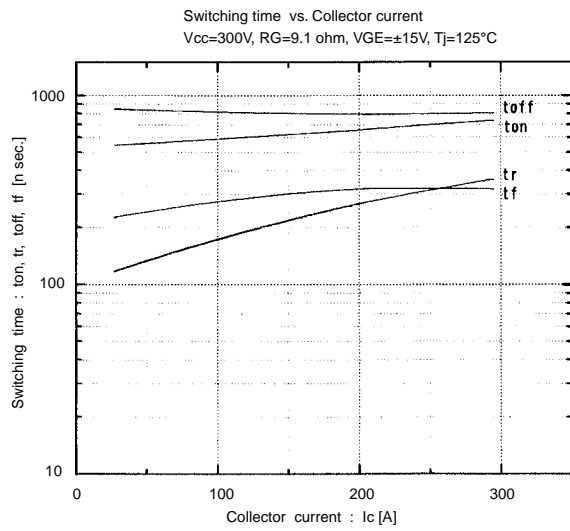
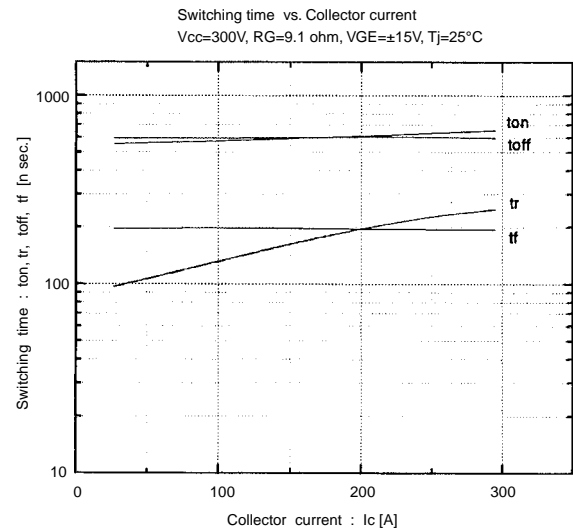
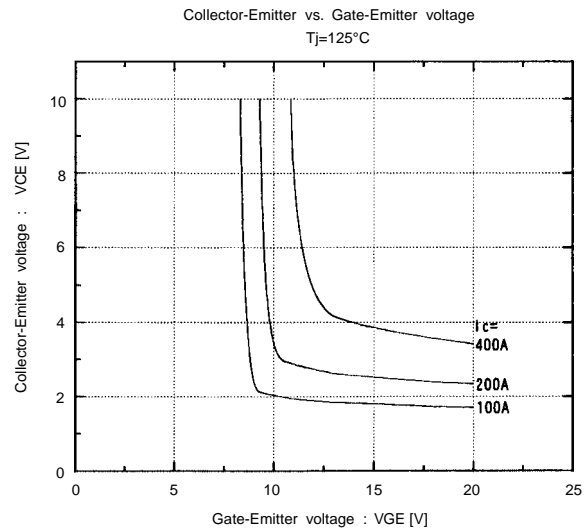
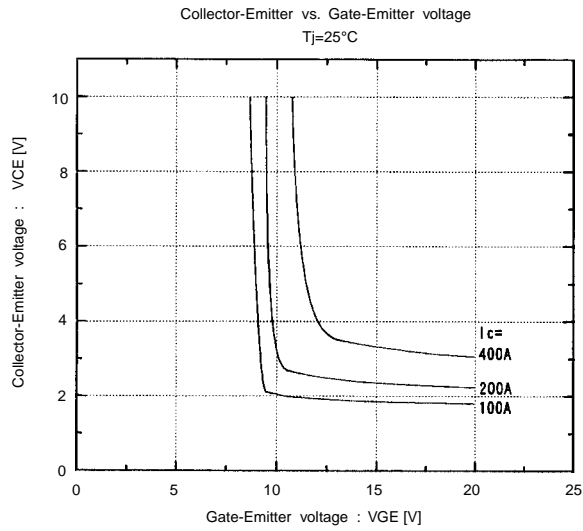
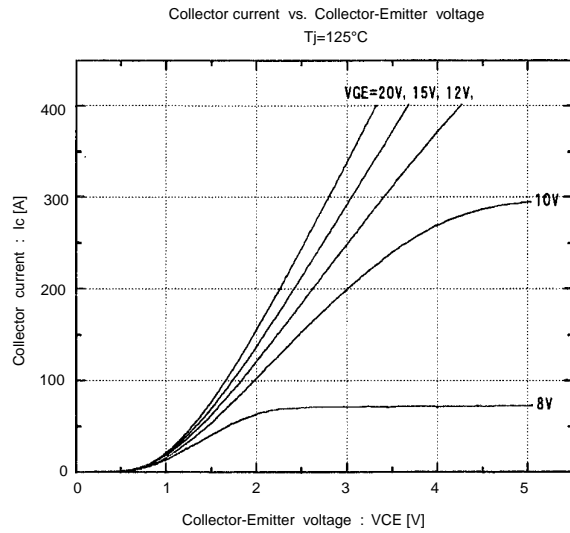
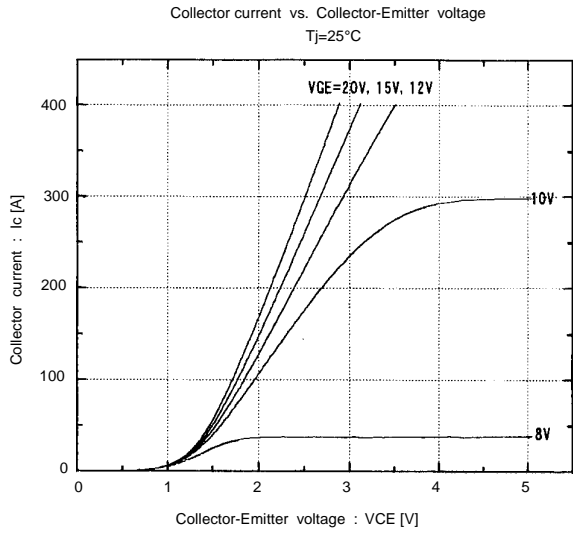

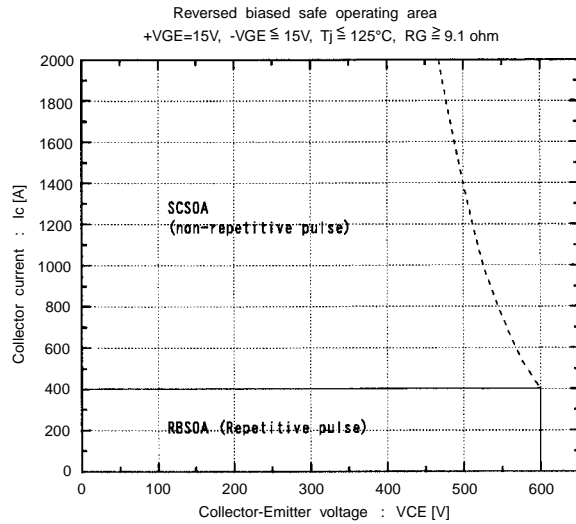
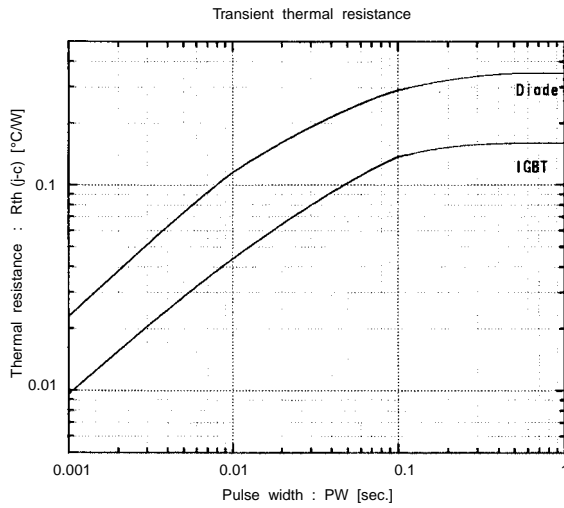
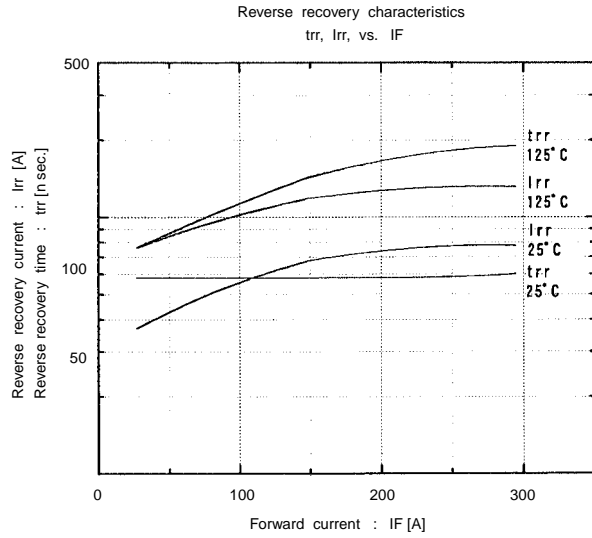
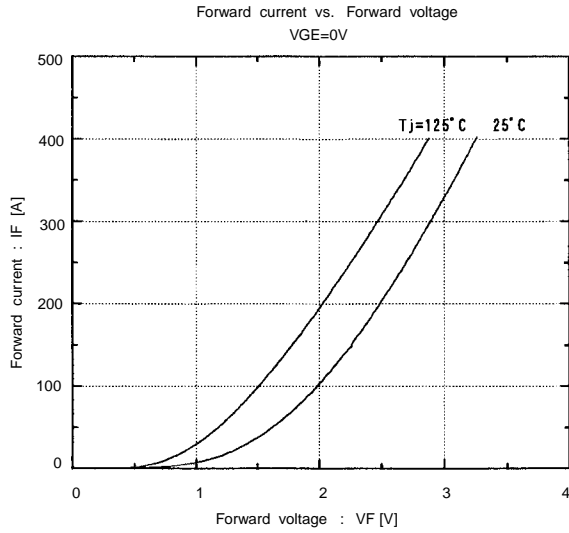
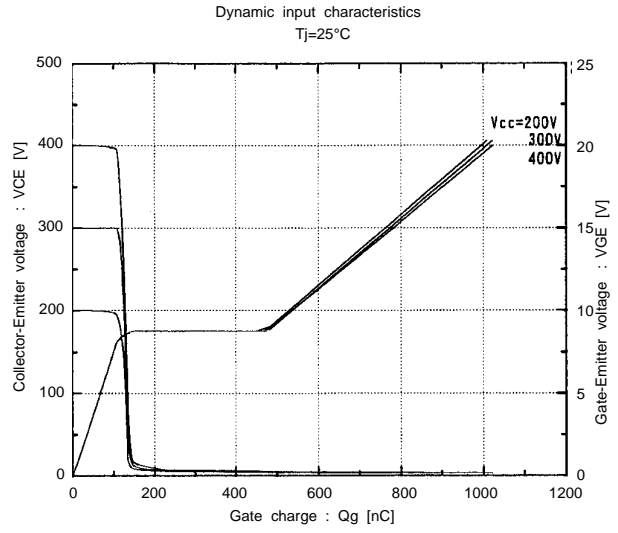
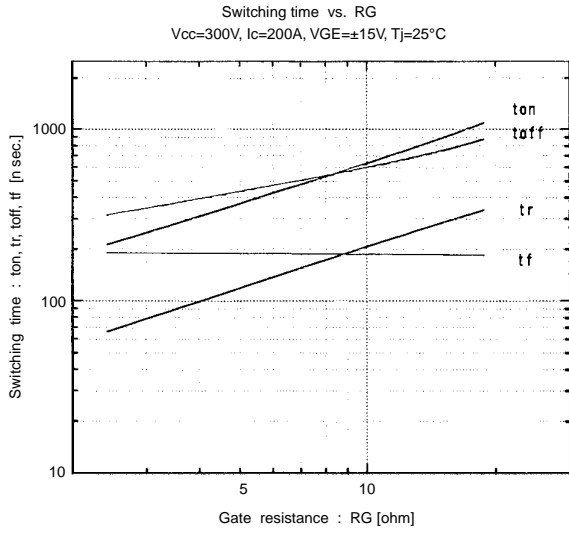

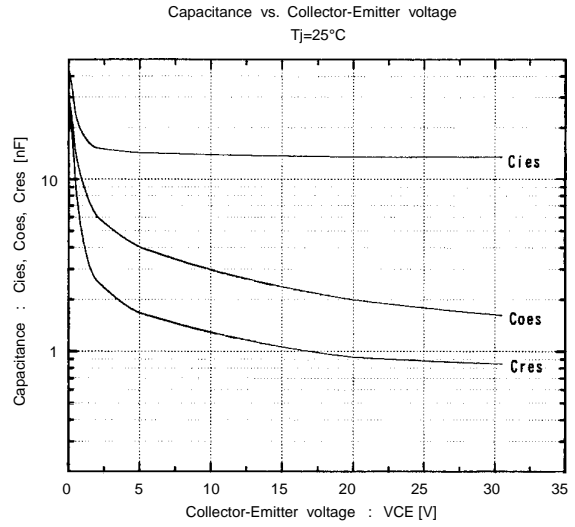
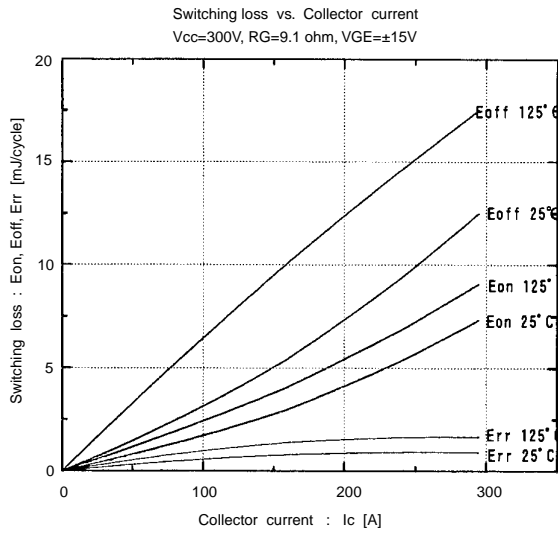

■ Outline Drawings, mm

