

100319

Low Power Hex Line Driver with Cut-Off

General Description

The 100319 is a Hex Line Driver with output cut-off capability. The 100319 has single ended ECL inputs and differential ECL outputs, designed to drive a differential, doubly terminated 50Ω transmission line (25Ω equivalent impedance) in an ECL backplane. A LOW on the Output Enable (OE) will set both the true and complementary outputs, to a high impedance or cut-off state. The cut-off state is designed to be more negative than a normal ECL LOW state.

Features

- Differential outputs
- Output cut-off capability
- Drives a 25Ω ECL load
- 2000V ESD protection
- Voltage compensated range = -4.2V to -5.7V
- Available to industrial grade temperature range

Ordering Code:

Order Number	Package Number	Package Description
100319QC	V28A	28-Lead Plastic Lead Chip Carrier (PLCC), JEDEC MO-047, 0.450 Square
100319QI	V28A	28-Lead Plastic Lead Chip Carrier (PLCC), JEDEC MO-047, 0.450 Square Industrial Temperature Range (-40°C to +85°C)

Devices also available in Tape and Reel. Specify by appending the suffix letter "X" to the ordering code.

Logic Symbol

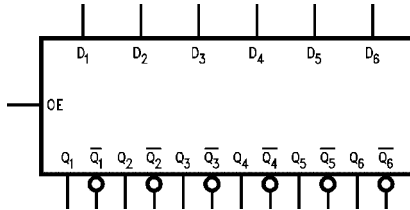

Connection Diagram

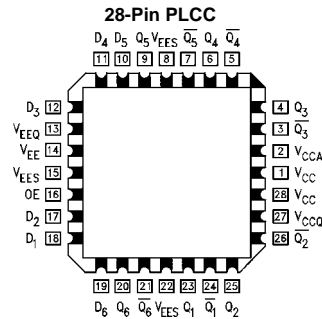

Pin Descriptions

Pin Names	Description
D_n	Data Inputs
Q_n	Data Outputs
\bar{Q}_n	Complementary Data Outputs
OE	Output Enable

100319

Truth Table

Inputs		Outputs	
D _n	OE	Q _n	\overline{Q}_n
L	H	L	H
H	H	H	L
X	L	Cut-Off	Cut-Off

H = HIGH Voltage Level
 L = LOW Voltage Level
 X = Don't Care
 Cut-off = Lower-than-LOW State

Logic Diagram

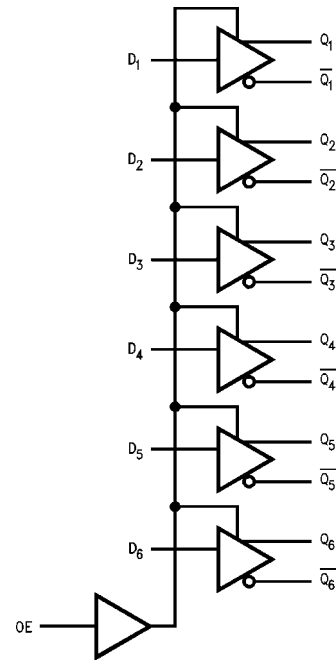

Absolute Maximum Ratings(Note 1)

Storage Temperature (T_{STG})	-65°C to +150°C
Maximum Junction Temperature (T_J)	+150°C
Pin Potential to Ground Pin (V_{EE})	-7.0V to +0.5V
Input Voltage (DC)	V_{EE} to +0.5V
Output Current (DC Output HIGH)	-100 mA
ESD (Note 2)	$\geq 2000V$

Recommended Operating Conditions

Case Temperature (T_C)	
Commercial	0°C to +85°C
Industrial	-40°C to +85°C
Supply Voltage (V_{EE})	-5.7V to -4.2V

Note 1: The "Absolute Maximum Ratings" are those values beyond which the safety of the device cannot be guaranteed. The device should not be operated at these limits. The parametric values defined in the Electrical Characteristics tables are not guaranteed at the absolute maximum rating. The "Recommended Operating Conditions" table will define the conditions for actual device operation.

Note 2: ESD testing conforms to MIL-STD-883, Method 3015.

Commercial Version**DC Electrical Characteristics** (Note 3)

$V_{EE} = -4.2V$ to $-5.7V$, $V_{CC} = V_{CCA} = GND$, $T_C = 0^\circ C$ to $+85^\circ C$

Symbol	Parameter	Min	Typ	Max	Units	Conditions	
V_{OH}	Output HIGH Voltage	-1025	-955	-870	mV	$V_{IN} = V_{IH(Max)}$	Loading with 25Ω to -2.0V
V_{OL}	Output LOW Voltage	-1830	-1705	-1620	mV	or $V_{IL(Min)}$	
V_{OHC}	Output HIGH Voltage	-1035			mV	$V_{IN} = V_{IH(Min)}$	Loading with 25Ω to -2.0V
V_{OLC}	Output LOW Voltage			-1610	mV	or $V_{IL(Max)}$	
V_{OLZ}	Cut-Off LOW Voltage			-1950	mV	$V_{IN} = V_{IH(Min)}$ or $V_{IL(Max)}$	OE = LOW
V_{IH}	Input HIGH Voltage	-1110		-870	mV	Guaranteed HIGH Signal for All Inputs	
V_{IL}	Input LOW Voltage	-1830		-1530	mV	Guaranteed LOW Signal for All Inputs	
I_{IL}	Input LOW Current			100	μA	$V_{IN} = V_{IL(Min)}$	
I_{IH}	Input HIGH Current			360	μA	$V_{IN} = V_{IH(Max)}$	
I_{EE}	Power Supply Current, Normal	-119		-30	mA		
I_{EEZ}	Power Supply Current, Cut-Off	-219		-75	mA	Inputs Open, OE = LOW	

Note 3: The specified limits represent the "worst case" value for the parameter. Since these values normally occur at the temperature extremes, additional noise immunity and guardbanding can be achieved by decreasing the allowable system operating ranges. Conditions for testing shown in the tables are chosen to guarantee operation under "worst case" conditions.

AC Electrical Characteristics

$V_{EE} = -4.2V$ to $-5.7V$, $V_{CC} = V_{CCA} = GND$

Symbol	Parameter	$T_C = 0^\circ C$		$T_C = +25^\circ C$		$T_C = +85^\circ C$		Units	Conditions
		Min	Max	Min	Max	Min	Max		
t_{PLH}	Propagation Delay Data to Output	0.65	2.10	0.65	2.10	0.65	2.10	ns	Figures 1, 2
t_{PZH}	Propagation Delay OE to Output	1.8	4.1	1.8	4.1	1.8	4.1	ns	
t_{PHZ}	Propagation Delay OE to Output	1.2	2.9	1.2	2.9	1.2	2.9	ns	
t_{TLH}	Transition Time 20% to 80%, 80% to 20%	0.45	1.30	0.45	1.30	0.45	1.30	ns	

Industrial Version**DC Electrical Characteristics** (Note 4) $V_{EE} = -4.2V$ to $-5.7V$, $V_{CC} = V_{CCA} = GND$

Symbol	Parameter	$T_C = -40^\circ C$		$T_C = 0^\circ C$ to $+85^\circ C$		Units	Conditions	
		Min	Max	Min	Max			
V_{OH}	Output HIGH Voltage	-1085	-870	-1025	-870	mV	$V_{IN} = V_{IH(Max)}$	Loading with 25Ω to $-2.0V$
V_{OL}	Output LOW Voltage	-1830	-1575	-1830	-1620	mV	or $V_{IL(Min)}$	
V_{OHC}	Output HIGH Voltage	-1095		-1035		mV	$V_{IN} = V_{IH(Min)}$	Loading with 25Ω to $-2.0V$
V_{OLC}	Output LOW Voltage		-1565		-1610	mV	or $V_{IL(Max)}$	
V_{IH}	Input HIGH Voltage	-1115	-870	-1110	-870	mV	Guaranteed HIGH Signal for All Inputs	
V_{OLZ}	Cut-Off LOW Voltage		-1900		-1950	mV	$V_{IN} = V_{IH(Min)}$ or $V_{IL(Max)}$	OE = LOW
V_{IL}	Input LOW Voltage	-1830	-1535	-1830	-1530	mV	Guaranteed LOW Signal for All Inputs	
I_{IL}	Input LOW Current		130		100	μA	$V_{IN} = V_{IL(Min)}$	
I_{IH}	Input HIGH Current		360		360	μA	$V_{IN} = V_{IH(Max)}$	
I_{EE}	Power Supply Current, Normal	-119	-30	-119	-30	mA		
I_{EEZ}	Power Supply Current, Cut-Off	-219	-75	-219	-75	mA	Inputs Open OE = LOW	

Note 4: The specified limits represent the "worst case" value for the parameter. Since these values normally occur at the temperature extremes, additional noise immunity and guardbanding can be achieved by decreasing the allowable system operating ranges. Conditions for testing shown in the tables are chosen to guarantee operation under "worst case" conditions.

AC Electrical Characteristics $V_{EE} = -4.2V$ to $-5.7V$, $V_{CC} = V_{CCA} = GND$

Symbol	Parameter	$T_C = -40^\circ C$		$T_C = +25^\circ C$		$T_C = +85^\circ C$		Units	Conditions
		Min	Max	Min	Max	Min	Max		
t_{PLH}	Propagation Delay	0.65	2.10	0.65	2.10	0.65	2.10	ns	Figure 1 Figure 2
t_{PHL}	Data to Output								
t_{PZH}	Propagation Delay	1.8	4.1	1.8	4.1	1.8	4.1	ns	
t_{PHZ}	OE to Output	1.2	2.9	1.2	2.9	1.2	2.9		
t_{TLH}	Transition Time	0.45	1.30	0.45	1.30	0.45	1.30	ns	
t_{THL}	20% to 80%, 80% to 20%								

Test Circuitry

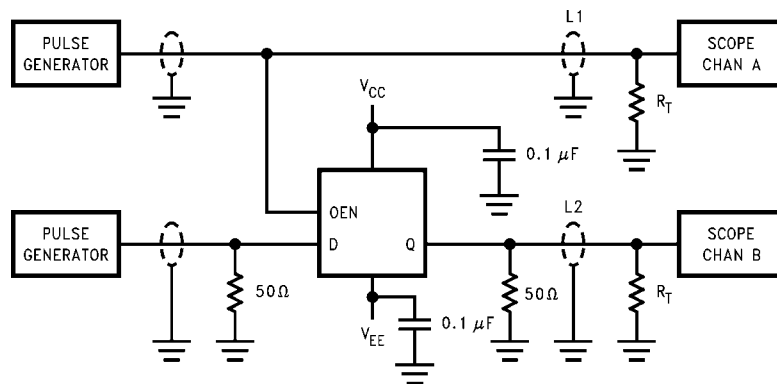

Notes:

- $V_{CC}, V_{CCA} = +2V, V_{EE} = -2.5V$
- L1 and L2 = equal length 50Ω impedance lines
- $R_T = 50\Omega$ terminator internal to scope
- Decoupling 0.1 μF from GND to V_{CC} and V_{EE}
- All unused outputs are loaded with 25Ω to GND
- $C_L =$ Fixture and stray capacitance ≤ 3 pF

FIGURE 1. AC Test Circuit

Switching Waveforms

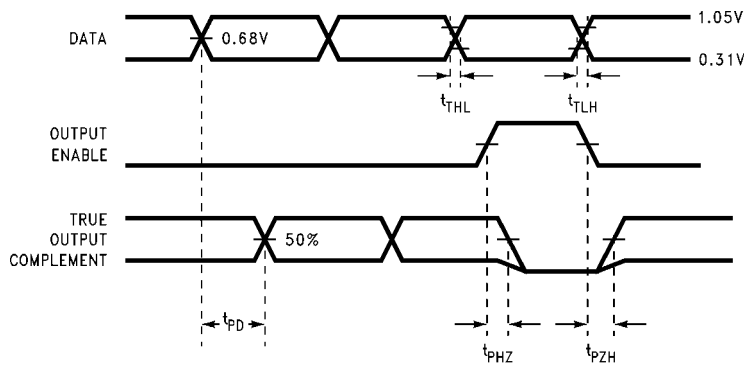

Note: The output AC measurement point for cut-off propagation delay testing = the 50% voltage point between active V_{OL} and V_{OH} .

FIGURE 2. Propagation Delay, Cut-Off and Transition Times

Physical Dimensions inches (millimeters) unless otherwise noted

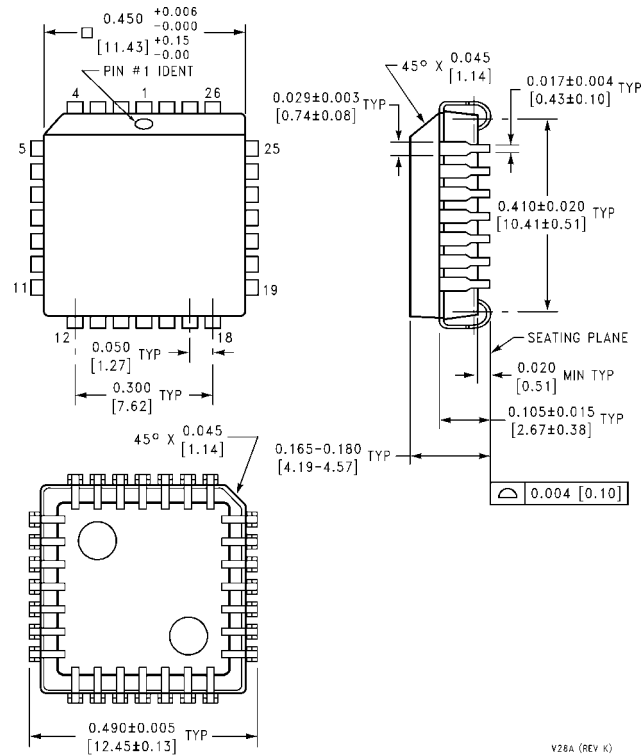

28-Lead Plastic Lead Chip Carrier (PLCC), JEDEC MO-047, 0.450 Square Package Number V28A

Fairchild does not assume any responsibility for use of any circuitry described, no circuit patent licenses are implied and Fairchild reserves the right at any time without notice to change said circuitry and specifications.

LIFE SUPPORT POLICY

FAIRCHILD'S PRODUCTS ARE NOT AUTHORIZED FOR USE AS CRITICAL COMPONENTS IN LIFE SUPPORT DEVICES OR SYSTEMS WITHOUT THE EXPRESS WRITTEN APPROVAL OF THE PRESIDENT OF FAIRCHILD SEMICONDUCTOR CORPORATION. As used herein:

1. Life support devices or systems are devices or systems which, (a) are intended for surgical implant into the body, or (b) support or sustain life, and (c) whose failure to perform when properly used in accordance with instructions for use provided in the labeling, can be reasonably expected to result in a significant injury to the user.
2. A critical component in any component of a life support device or system whose failure to perform can be reasonably expected to cause the failure of the life support device or system, or to affect its safety or effectiveness.

www.fairchildsemi.com