

100324

Low Power Hex TTL-to-ECL Translator

General Description

The 100324 is a hex translator, designed to convert TTL logic levels to 100K ECL logic levels. The inputs are compatible with standard or Schottky TTL. A common Enable (E), when LOW, holds all inverting outputs HIGH and holds all true outputs LOW. The differential outputs allow each circuit to be used as an inverting/non-inverting translator, or as a differential line driver. The output levels are voltage compensated over the full $-4.2V$ to $-5.7V$ range.

When the circuit is used in the differential mode, the 100324, due to its high common mode rejection, overcomes voltage gradients between the TTL and ECL ground systems. The V_{EE} and V_{TTL} power may be applied in either order.

The 100324 is pin and function compatible with the 100124 with similar AC performance, but features power dissipation roughly half of the 100124 to ease system cooling requirements.

Features

- Pin/function compatible with 100124
- Meets 100124 AC specifications
- 50% power reduction of the 100124
- Differential outputs
- 2000V ESD protection
- $-4.2V$ to $-5.7V$ operating range
- Available to MIL-STD-883
- Available to industrial grade temperature range (PLCC package only)

Ordering Code:

Order Number	Package Number	Package Description
100324SC	M24B	28-Lead Small Outline Integrated Circuit (SOIC), JEDEC MS-013, 0.300 Wide
100324PC	N24E	24-Lead Plastic Dual-In-Line Package (PDIP), JEDEC MS-011, 0.400 Wide
100324QC	V28A	28-Lead Plastic Lead Chip Carrier (PLCC), JEDEC MO-047, 0.450 Square
100324QI	V28A	28-Lead Plastic Lead Chip Carrier (PLCC), JEDEC MO-047, 0.450 Square Industrial Temperature Range ($-40^{\circ}C$ to $+85^{\circ}C$)

Devices also available in Tape and Reel. Specify by appending the suffix letter "X" to the ordering code.

Connection Diagrams

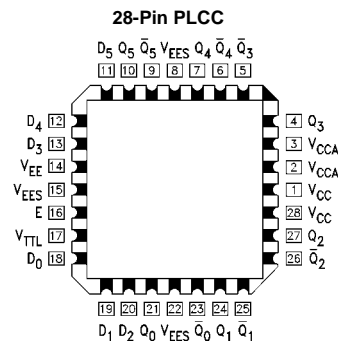
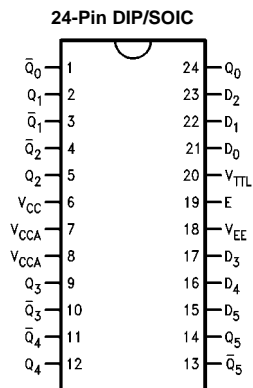

Pin Descriptions

Pin Names	Description
D_0 - D_5	Data Inputs
E	Enable Input
Q_0 - Q_5	Data Outputs
$\overline{Q_0}$ - $\overline{Q_5}$	Complementary Data Outputs

Truth Table

Inputs		Outputs	
D_n	E	Q_n	$\overline{Q_n}$
X	L	L	H
L	H	L	H
H	H	H	L

H = HIGH Voltage Level
L = LOW Voltage Level

Logic Diagram

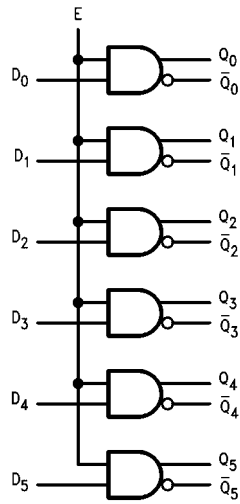

Absolute Maximum Ratings(Note 1)

Storage Temperature (T_{STG})	-65°C to +150°C
Maximum Junction Temperature (T_J)	+150°C
V_{EE} Pin Potential to Ground Pin	-7.0V to +0.5V
V_{TTL} Pin Potential to Ground Pin	-0.5V to +6.0V
Input Voltage (DC)	-0.5V to +6.0V
Output Current (DC Output HIGH)	-50 mA
ESD (Note 2)	≥2000V

Recommended Operating Conditions

Case Temperature (T_C)	Commercial	0°C to +85°C
	Industrial	-40°C to +85°C
Supply Voltage (V_{EE})		-5.7V to -4.2V

Note 1: The "Absolute Maximum Ratings" are those values beyond which the safety of the device cannot be guaranteed. The device should not be operated at these limits. The parametric values defined in the Electrical Characteristics tables are not guaranteed at the absolute maximum rating. The "Recommended Operating Conditions" table will define the conditions for actual device operation.

Note 2: ESD testing conforms to MIL-STD-883, Method 3015.

Commercial Version**DC Electrical Characteristics** (Note 3)

$V_{EE} = -4.2V$ to $-5.7V$, $V_{CC} = V_{CCA} = GND$, $T_C = 0°C$ to $+85°C$, $V_{TTL} = +4.5V$ to $+5.5V$

Symbol	Parameter	Min	Typ	Max	Units	Conditions
V_{OH}	Output HIGH Voltage	-1025	-955	-870	mV	$V_{IN} = V_{IH}(\text{Max})$ or $V_{IL}(\text{Min})$ Loading with 50Ω to -2.0V
V_{OL}	Output LOW Voltage	-1830	-1705	-1620		
V_{OHC}	Output HIGH Voltage	-1035			mV	$V_{IN} = V_{IH}(\text{Min})$ or $V_{IL}(\text{Max})$ Loading with 50Ω to -2.0V
V_{OLC}	Output LOW Voltage			-1610		
V_{IH}	Input HIGH Voltage	2.0		5.0	V	Guaranteed HIGH Signal for All Inputs
V_{IL}	Input LOW Voltage	0		0.8	V	Guaranteed LOW Signal for All Inputs
V_{CD}	Input Clamp Diode Voltage	-1.2			V	$I_{IN} = -18$ mA
I_{IH}	Input HIGH Current Data			20	μA	$V_{IN} = +2.4V$, All Other Inputs $V_{IN} = GND$
	Enable			120		
I_{IL}	Input HIGH Current Breakdown Test, All Inputs			1.0	mA	$V_{IN} = +5.5V$, All Other Inputs = GND
	Input LOW Current Data	-0.9				
I_{IL}	Input LOW Current Enable	-5.4			mA	$V_{IN} = +0.4V$, All Other Inputs $V_{IN} = V_{IH}$
I_{EE}	V_{EE} Power Supply Current	-70	-45	-22	mA	All Inputs $V_{IN} = +4.0V$
I_{TTL}	V_{TTL} Power Supply Current		25	38	mA	All Inputs $V_{IN} = GND$

Note 3: The specified limits represent the "worst case" value for the parameter. Since these values normally occur at the temperature extremes, additional noise immunity and guardbanding can be achieved by decreasing the allowable system operating ranges. Conditions for testing shown in the tables are chosen to guarantee operation under "worst case" conditions.

DIP AC Electric Characteristics

$V_{EE} = -4.2V$ to $-5.7V$, $V_{CC} = V_{CCA} = GND$, $V_{TTL} = +4.5V$ to $+5.5V$

Symbol	Parameter	$T_C = 0°C$		$T_C = +25°C$		$T_C = +85°C$		Units	Conditions
		Min	Max	Min	Max	Min	Max		
t_{PLH}	Propagation Delay	0.50	3.00	0.50	2.90	0.50	3.00	ns	Figures 2, 1
t_{PHL}	Data and Enable to Output								
t_{TLH}	Transition Time	0.45	1.80	0.45	1.80	0.45	1.80		
t_{THL}	20% to 80%, 80% to 20%								

Commercial Version (Continued) SOIC and PLCC AC Electrical Characteristics

$V_{EE} = -4.2V$ to $-5.7V$, $V_{CC} = V_{CCA} = GND$, $V_{TTL} = +4.5V$ to $+5.5V$

Symbol	Parameter	$T_C = 0^\circ C$		$T_C = +25^\circ C$		$T_C = +85^\circ C$		Units	Conditions
		Min	Max	Min	Max	Min	Max		
t_{PLH} t_{PHL}	Propagation Delay Data and Enable to Output	0.50	2.80	0.50	2.70	0.50	2.80	ns	Figures 2, 1
t_{TLH} t_{THL}	Transition Time 20% to 80%, 80% to 20%	0.45	1.70	0.45	1.70	0.45	1.70	ns	
t_{OSHL}	Maximum Skew Common Edge Output-to-Output Variation Data to Output Path		0.95		0.95		0.95	ns	PLCC Only (Note 4)
t_{OSLH}	Maximum Skew Common Edge Output-to-Output Variation Data to Output Path		0.70		0.70		0.70	ns	PLCC Only (Note 4)
t_{OST}	Maximum Skew Opposite Edge Output-to-Output Variation Data to Output Path		1.60		1.60		1.60	ns	PLCC Only (Note 4)
t_{PS}	Maximum Skew Pin (Signal) Transition Variation Data to Output Path		1.20		1.20		1.20	ns	PLCC Only (Note 4)

Note 4: Output-to-Output Skew is defined as the absolute value of the difference between the actual propagation delay for any outputs within the same packaged device. The specifications apply to any outputs switching in the same direction either HIGH-to-LOW (t_{OSHL}), or LOW-to-HIGH (t_{OSLH}), or in opposite directions both HL and LH (t_{OST}). Parameters t_{OST} and t_{PS} guaranteed by design.

Industrial Version

DC Electrical Characteristics (Note 5)

$V_{EE} = -4.2V$ to $-5.7V$, $V_{CC} = V_{CCA} = GND$, $T_C = -40^\circ C$ to $+85^\circ C$, $V_{TTL} = +4.5V$ to $+5.5V$

Symbol	Parameter	$T_C = -40^\circ C$		$T_C = 0^\circ C$ to $+85^\circ C$		Units	Conditions	
		Min	Max	Min	Max			
V_{OH}	Output HIGH Voltage	-1085	-870	-1025	-870	mV	$V_{IN} = V_{IH}(\text{Max})$ or $V_{IL}(\text{Min})$	Loading with 50Ω to -2.0V
V_{OL}	Output LOW Voltage	-1830	-1575	-1830	-1620			
V_{OHC}	Output HIGH Voltage	-1095		-1035		mV	$V_{IN} = V_{IH}(\text{Min})$ or $V_{IL}(\text{Max})$	Loading with 50Ω to -2.0V
V_{OLC}	Output LOW Voltage		-1565		-1610			
V_{IH}	Input HIGH Voltage	2.0	5.0	2.0	5.0	V	Guaranteed HIGH Signal for All Inputs	
V_{IL}	Input LOW Voltage	0	0.8	0	0.8	V	Guaranteed LOW Signal for All Inputs	
V_{CD}	Input Clamp Diode Voltage	-1.2		-1.2		V	$I_{IN} = -18$ mA	
I_{IH}	Input HIGH Current					μA	$V_{IN} = +2.4V$, All Other Inputs $V_{IN} = GND$	
	Data		20		20			
	Enable		120		120			
	Input HIGH Current Breakdown Test, All Inputs		1.0		1.0	mA	$V_{IN} = +5.5V$, All Other Inputs = GND	
I_{IL}	Input LOW Current					mA	$V_{IN} = +0.4V$, All Other Inputs $V_{IN} = V_{IH}$	
	Data	-0.9		-0.9				
	Enable	-5.4		-5.4				
I_{EE}	V_{EE} Power Supply Current	-70	-22	-70	-22	mA	All Inputs $V_{IN} = +4.0V$	
I_{TTL}	V_{TTL} Power Supply Current		38		38	mA	All Inputs $V_{IN} = GND$	

Note 5: The specified limits represent the "worst case" value for the parameter. Since these values normally occur at the temperature extremes, additional noise immunity and guardbanding can be achieved by decreasing the allowable system operating ranges. Conditions for testing shown in the tables are chosen to guarantee operation under "worst case" conditions.

AC Electrical Characteristics

$V_{EE} = -4.2V$ to $-5.7V$, $V_{CC} = V_{CCA} = GND$, $V_{TTL} = +4.5V$ to $+5.5V$

Symbol	Parameter	$T_C = -40^\circ C$		$T_C = +25^\circ C$		$T_C = +85^\circ C$		Units	Conditions
		Min	Max	Min	Max	Min	Max		
t_{PLH}	Propagation Delay	0.50	2.80	0.50	2.70	0.50	2.80	ns	Figures 2, 1
t_{PHL}	Data and Enable to Output								
t_{TLH}	Transition Times	0.35	1.80	0.45	1.70	0.45	1.70	ns	Figures 2, Figure 1
t_{THL}	20% to 80%, 80% to 20%								

Test Circuit

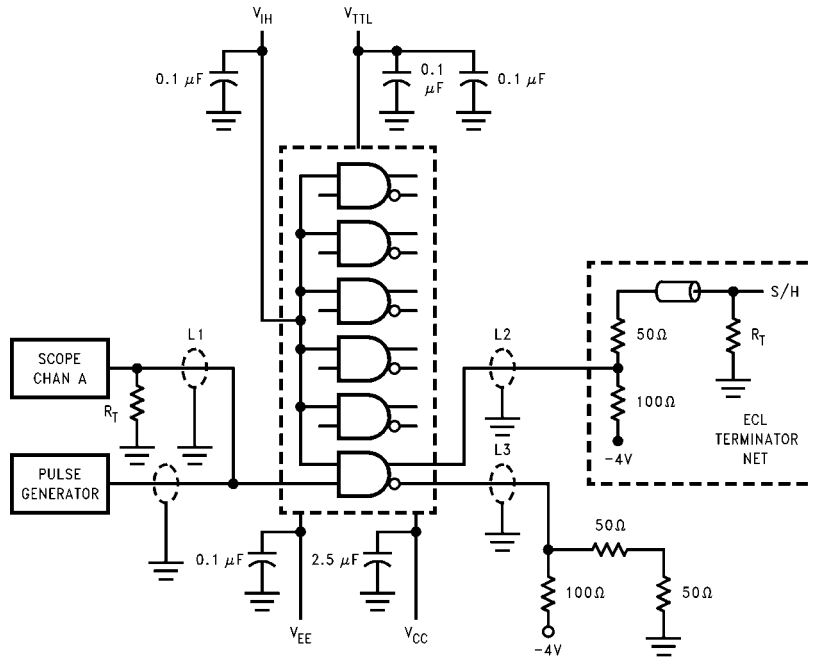

Note:

- $V_{CC}, V_{CCA} = 0V, V_{EE} = -4.5V, V_{TTL} = +5.0V, V_{IH} = +3.0V$
- L1, L2 and L3 = equal length 50Ω impedance lines
- $R_T = 50\Omega$ terminator internal to scope
- Decoupling 0.1 μF from GND to V_{CC}, V_{EE} and V_{TTL}
- All unused outputs are loaded with 50Ω to -2V or with equivalent ECL terminator network
- C_L = Fixture and stray capacitance ≤ 3 pF

FIGURE 1. AC Test Circuit

Switching Waveform

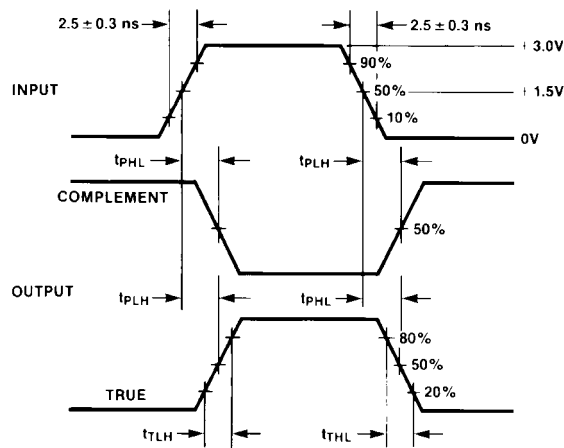
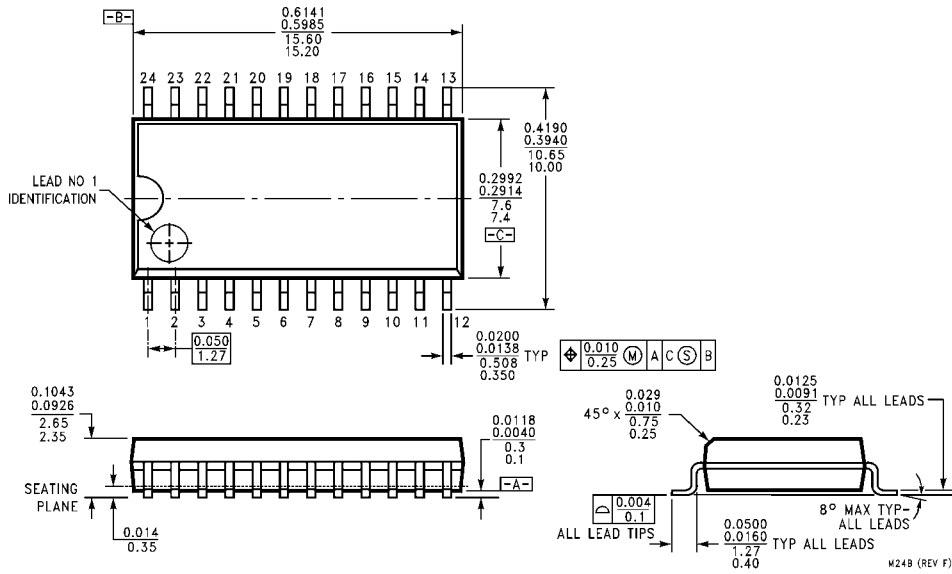
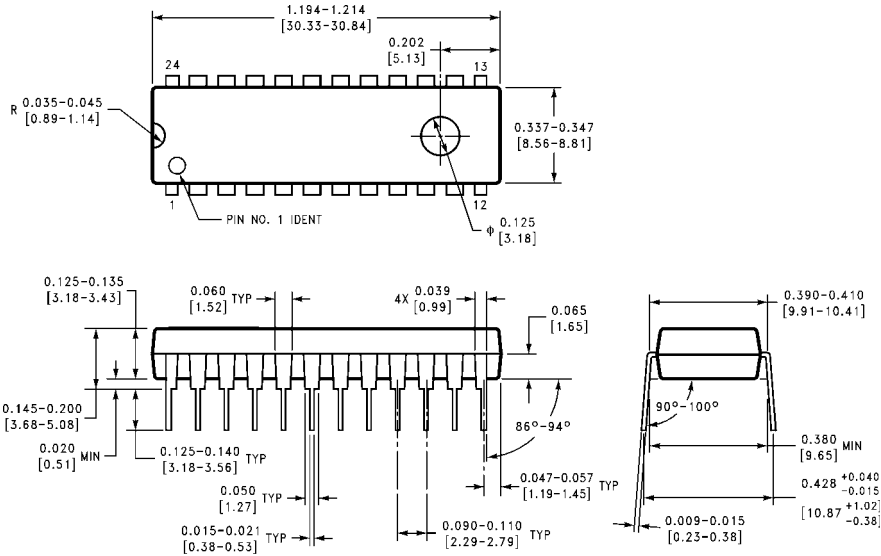

FIGURE 2. Propagation Delay and Transition Times

Physical Dimensions inches (millimeters) unless otherwise noted



**28-Lead Small Outline Integrated Circuit (SOIC), JEDEC MS-013, 0.300 Wide
Package Number M24B**



**24-Lead Plastic Dual-In-Line Package (PDIP), JEDEC MS-011, 0.400 Wide
Package Number N24E**

Physical Dimensions inches (millimeters) unless otherwise noted (Continued)

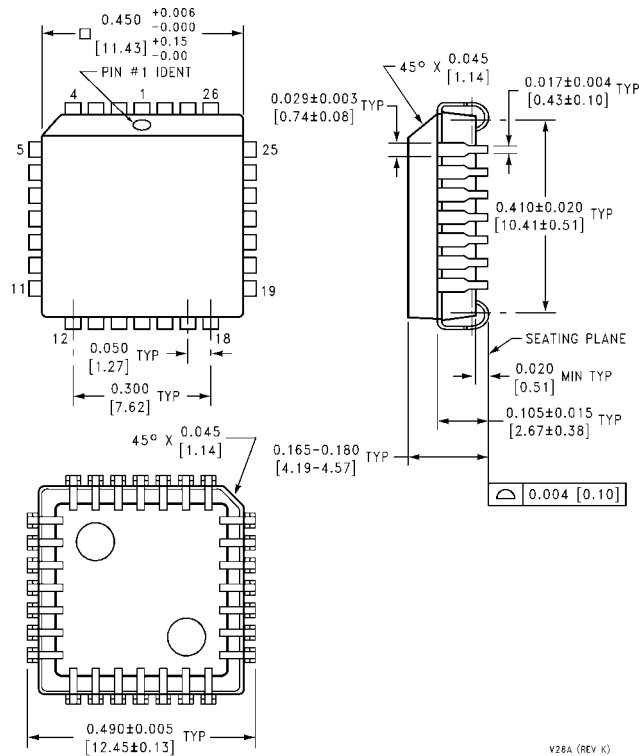

28-Lead Plastic Lead Chip Carrier (PLCC), JEDEC MO-047, 0.450 Square
Package Number V28A

V28A (REV K)

Fairchild does not assume any responsibility for use of any circuitry described, no circuit patent licenses are implied and Fairchild reserves the right at any time without notice to change said circuitry and specifications.

LIFE SUPPORT POLICY

FAIRCHILD'S PRODUCTS ARE NOT AUTHORIZED FOR USE AS CRITICAL COMPONENTS IN LIFE SUPPORT DEVICES OR SYSTEMS WITHOUT THE EXPRESS WRITTEN APPROVAL OF THE PRESIDENT OF FAIRCHILD SEMICONDUCTOR CORPORATION. As used herein:

1. Life support devices or systems are devices or systems which, (a) are intended for surgical implant into the body, or (b) support or sustain life, and (c) whose failure to perform when properly used in accordance with instructions for use provided in the labeling, can be reasonably expected to result in a significant injury to the user.
2. A critical component in any component of a life support device or system whose failure to perform can be reasonably expected to cause the failure of the life support device or system, or to affect its safety or effectiveness.

www.fairchildsemi.com