

100329 Low Power Octal ECL/TTL Bidirectional Translator with Register

General Description

The 100329 is an octal registered bidirectional translator designed to convert TTL logic levels to 100K ECL logic levels and vice versa. The direction of the translation is determined by the DIR input. A LOW on the output enable input (OE) holds the ECL outputs in a cut-off state and the TTL outputs at a high impedance level. The outputs change synchronously with the rising edge of the clock input (CP) even though only one output is enabled at the time.

The cut-off state is designed to be more negative than a normal ECL LOW level. This allows the output emitter-followers to turn off when the termination supply is $-2.0V$, presenting a high impedance to the data bus. This high impedance reduces the termination power and prevents loss of low state noise margin when several loads share the bus.

The 100329 is designed with FAST™ TTL output buffers, featuring optimal DC drive and capable of quickly charging and discharging highly capacitive loads. All inputs have $50\text{ k}\Omega$ pull-down resistors.

Features

- Bidirectional translation
- ECL high impedance outputs
- Registered outputs
- FAST TTL outputs
- 3-STATE outputs
- Voltage compensated operating range = $-4.2V$ to $-5.7V$
- High drive IOS

Ordering Code:

Order Number	Package Number	Package Description
100329PC	N24E	24-Lead Plastic Dual-In-Line Package (PDIP), JEDEC MS-011, 0.400 Wide
100329QC	V28A	28-Lead Plastic Lead Chip Carrier (PLCC), JEDEC MO-047, 0.450 Square
100329QI	V28A	28-Lead Plastic Lead Chip Carrier (PLCC), JEDEC MO-047, 0.450 Square Industrial Temperature Range ($-40^{\circ}C$ to $+85^{\circ}C$)

Devices also available in Tape and Reel. Specify by appending suffix letter "X" to the ordering code.

Connection Diagrams

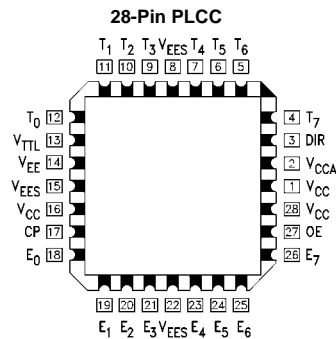
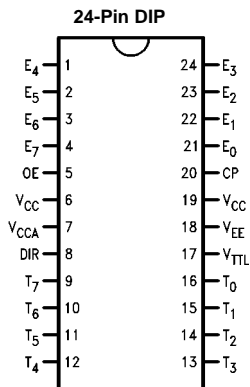

FAST® is a registered trademark of Fairchild Semiconductor Corporation.

Logic Symbol

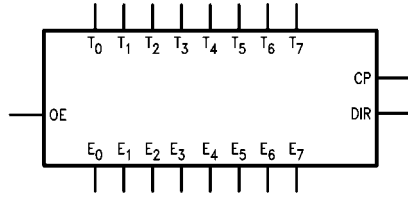

Pin Descriptions

Pin Names	Description
E ₀ -E ₇	ECL Data I/O
T ₀ -T ₇	TTL Data I/O
OE	Output Enable Input
CP	Clock Pulse Input (Active Rising Edge)
DIR	Direction Control Input

All pins function at 100K ECL levels except for T₀-T₇.

Truth Table

OE	DIR	CP	ECL Port	TTL Port	Notes
L	L	X	Input	Z	(Note 1)(Note 3)
L	H	X	LOW (Cut-Off)	Input	(Note 2)(Note 3)
H	L	↗	L	L	(Note 1)
H	L	↗	H	H	(Note 1)
H	L	L	X	NC	(Note 1)(Note 3)
H	H	↗	L	L	(Note 2)
H	H	↗	H	H	(Note 2)
H	H	L	NC	X	(Note 2)(Note 3)

H = HIGH Voltage Level
 L = LOW Voltage Level
 X = Don't Care
 Z = High Impedance
 ↗ = LOW-to-HIGH Clock Transition
 NC = No Change

Note 1: ECL input to TTL output mode.
Note 2: TTL input to ECL output mode.
Note 3: Retains data present before CP.

Functional Diagram

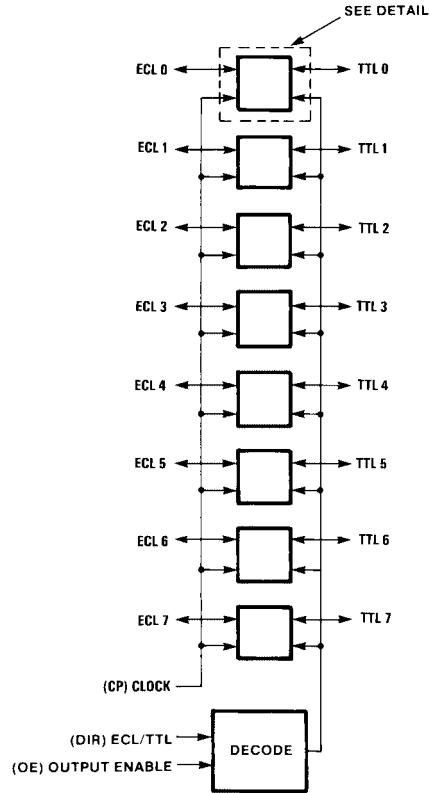

Note: DIR and OE use ECL logic levels

Detail

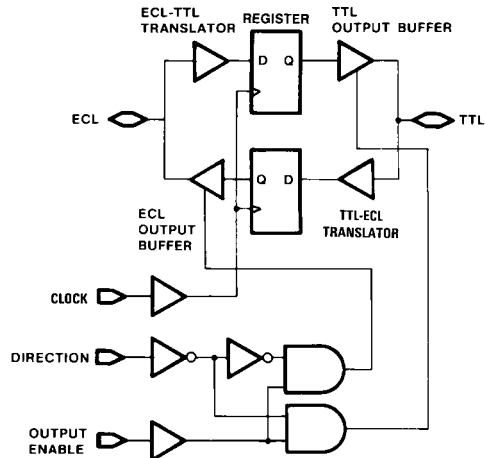

Absolute Maximum Ratings(Note 4)

Storage Temperature (T_{STG})	-65°C to +150°C
Maximum Junction Temperature (T_j)	+150°C
V_{EE} Pin Potential to Ground Pin	-7.0V to +0.5V
V_{TTL} Pin Potential to Ground Pin	-0.5V to +6.0V
ECL Input Voltage (DC)	V_{EE} to +0.5V
ECL Output Current (DC Output HIGH)	-50 mA
TTL Input Voltage (Note 6)	-0.5V to +6.0V
TTL Input Current (Note 6)	-30 mA to +5.0 mA
Voltage Applied to Output in HIGH State	
3-STATE Output	-0.5V to +5.5V
Current Applied to TTL Output in LOW State (Max)	twice the rated I_{OL} (mA)
ESD (Note 5)	$\geq 2000V$

Recommended Operating Conditions

Case Temperature (T_C)	0°C to +85°C
ECL Supply Voltage (V_{EE})	-5.7V to -4.2V
TTL Supply Voltage (V_{TTL})	+4.5V to +5.5V

Note 4: The "Absolute Maximum Ratings" are those values beyond which the safety of the device cannot be guaranteed. The device should not be operated at these limits. The parametric values defined in the Electrical Characteristics tables are not guaranteed at the absolute maximum rating. The "Recommended Operating Conditions" table will define the conditions for actual device operation.

Note 5: ESD testing conforms to MIL-STD-883, Method 3015.

Note 6: Either voltage limit or current limit is sufficient to protect inputs.

TTL-to-ECL DC Electrical Characteristics

$V_{EE} = -4.2V$ to $-5.7V$, $V_{CC} = V_{CCA} = GND$, $T_C = 0^\circ C$ to $+85^\circ C$, $V_{TTL} = +4.5V$ to $+5.5V$ (Note 7)

Symbol	Parameter	Min	Typ	Max	Units	Conditions
V_{OH}	Output HIGH Voltage	-1025	-955	-870	mV	$V_{IN} = V_{IH}$ (Max) or V_{IL} (Min)
V_{OL}	Output LOW Voltage	-1830	-1705	-1620	mV	Loading with 50Ω to -2V
	Cutoff Voltage		-2000	-1950	mV	OE or DIR LOW, $V_{IN} = V_{IH}$ (Max) or V_{IL} (Min) Loading with 50Ω to -2V
V_{OHC}	Output HIGH Voltage Corner Point HIGH	-1035			mV	$V_{IN} = V_{IH}$ (Min) or V_{IL} (Max)
V_{OLC}	Output LOW Voltage Corner Point LOW			-1610	mV	Loading with 50Ω to -2V
V_{IH}	Input HIGH Voltage	2.0		5.0	V	Over V_{TTL} , V_{EE} , T_C Range
V_{IL}	Input LOW Voltage	0		0.8	V	Over V_{TTL} , V_{EE} , T_C Range
I_{IH}	Input HIGH Current			70	μA	$V_{IN} = +2.7V$
	Breakdown Test			1.0	mA	$V_{IN} = +5.5V$
I_{IL}	Input LOW Current	-700			μA	$V_{IN} = +0.5V$
V_{FCD}	Input Clamp	-1.2			V	$I_{IN} = -18$ mA
	Diode Voltage					
I_{EE}	V_{EE} Supply Current				mA	LE LOW, OE and DIR HIGH Inputs Open
		-189		-94		$V_{EE} = -4.2V$ to $-4.8V$
		-199		-94		$V_{EE} = -4.2V$ to $-5.7V$

Note 7: The specified limits represent the "worst case" value for the parameter. Since these values normally occur at the temperature extremes, additional noise immunity and guardbanding can be achieved by decreasing the allowable system operating ranges. Conditions for testing shown in the tables are chosen to guarantee operation under "worst case" conditions.

ECL-to-TTL DC Electrical Characteristics

$V_{EE} = -4.2V$ to $-5.7V$, $V_{CC} = V_{CCA} = GND$, $T_C = 0^\circ C$ to $+85^\circ C$, $C_L = 50$ pF, $V_{TTL} = +4.5V$ to $+5.5V$ (Note 8)

Symbol	Parameter	Typ			Units	Conditions
		Min	Typ	Max		
V_{OH}	Output HIGH Voltage	2.7	3.1		V	$I_{OH} = -3$ mA, $V_{TTL} = 4.75V$
		2.4	2.9		V	$I_{OH} = -3$ mA, $V_{TTL} = 4.50V$
V_{OL}	Output LOW Voltage		0.3	0.5	V	$I_{OL} = 24$ mA, $V_{TTL} = 4.50V$
V_{IH}	Input HIGH Voltage	-1165		-870	mV	Guaranteed HIGH Signal for All Inputs
V_{IL}	Input LOW Voltage	-1830		-1475	mV	Guaranteed LOW Signal for All Inputs
I_{IH}	Input HIGH Current			350	μA	$V_{IN} = V_{IH}$ (Max)
I_{IL}	Input LOW Current	0.50			μA	$V_{IN} = V_{IL}$ (Min)
I_{OZHT}	3-STATE Current Output HIGH			70	μA	$V_{OUT} = +2.7V$
I_{OZLT}	3-STATE Current Output LOW	-700			μA	$V_{OUT} = +0.5V$
I_{OS}	Output Short-Circuit Current	-225		-100	mA	$V_{OUT} = 0.0V$, $V_{TTL} = +5.5V$
I_{TTL}	V_{TTL} Supply Current			74	mA	TTL Outputs LOW
				49	mA	TTL Outputs HIGH
				67	mA	TTL Outputs in 3-STATE

Note 8: The specified limits represent the "worst case" value for the parameter. Since these values normally occur at the temperature extremes, additional noise immunity and guardbanding can be achieved by decreasing the allowable system operating ranges. Conditions for testing shown in the tables are chosen to guarantee operation under "worst case" conditions.

DIP TTL-to-ECL AC Electrical Characteristics

$V_{EE} = -4.2V$ to $-5.7V$, $V_{TTL} = +4.5V$ to $+5.5V$, $V_{CC} = V_{CCA} = GND$

Symbol	Parameter	$T_C = 0^\circ C$		$T_C = 25^\circ C$		$T_C = 85^\circ C$		Units	Conditions
		Min	Max	Min	Max	Min	Max		
f_{MAX}	Max Toggle Frequency	350		350		350		MHz	
t_{PLH} t_{PHL}	CP to E_n	1.7	3.6	1.7	3.7	1.9	3.9	ns	Figures 1, 2
t_{PZH}	OE to E_n (Cutoff to HIGH)	1.3	4.2	1.5	4.4	1.7	4.8	ns	Figures 1, 2
t_{PHZ}	OE to E_n (HIGH to Cutoff)	1.5	4.5	1.6	4.5	1.6	4.6	ns	Figures 1, 2
t_{PHZ}	DIR to E_n (HIGH to Cutoff)	1.6	4.3	1.6	4.3	1.7	4.5	ns	Figures 1, 2
t_{SET}	T_n to CP	1.1		1.1		1.1		ns	Figures 1, 2
t_{HOLD}	T_n to CP	1.7		1.7		1.9		ns	Figures 1, 2
$t_{PW}(H)$	Pulse Width CP	2.1		2.1		2.1		ns	Figures 1, 2
t_{TLH} t_{THL}	Transition Time 20% to 80%, 80% to 20%	0.6	1.6	0.6	1.6	0.6	1.6	ns	Figures 1, 2

DIP ECL-to-TTL AC Electrical Characteristics

$V_{EE} = -4.2V$ to $-5.7V$, $V_{TTL} = +4.5V$ to $+5.5V$, $V_{CC} = V_{CCA} = GND$, $C_L = 50$ pF

Symbol	Parameter	$T_C = 0^\circ C$		$T_C = 25^\circ C$		$T_C = 85^\circ C$		Units	Conditions
		Min	Max	Min	Max	Min	Max		
f_{MAX}	Max Toggle Frequency	125		125		125		MHz	
t_{PLH}	CP to T_n	3.1	7.2	3.1	7.2	3.3	7.7	ns	Figures 3, 4
t_{PHL}									
t_{PZH}	OE to T_n	3.4	8.45	3.7	8.95	4.0	9.7	ns	Figures 3, 5
t_{PZL}	(Enable Time)	3.8	9.2	4.0	9.2	4.3	9.95		
t_{PHZ}	OE to T_n	3.2	8.95	3.3	8.95	3.5	9.2	ns	Figures 3, 5
t_{PLZ}	(Disable Time)	3.0	7.7	3.4	8.7	4.1	9.95		
t_{PHZ}	DIR to T_n	2.7	8.2	2.8	8.7	3.1	8.95	ns	Figures 3, 6
t_{PLZ}	(Disable Time)	2.8	7.45	3.1	7.95	4.0	9.2		
t_{SET}	E_n to CP	1.1		1.1		1.1		ns	Figures 3, 4
t_{HOLD}	E_n to CP	2.1		2.1		2.6		ns	Figures 3, 4
$t_{PW(H)}$	Pulse Width CP	4.1		4.1		4.1		ns	Figures 3, 4

PLCC and TTL-to-ECL AC Electrical Characteristics

$V_{EE} = -4.2V$ to $-5.7V$, $V_{TTL} = +4.5V$ to $+5.5V$

Symbol	Parameter	$T_C = 0^\circ C$		$T_C = 25^\circ C$		$T_C = 85^\circ C$		Units	Conditions
		Min	Max	Min	Max	Min	Max		
f_{MAX}	Max Toggle Frequency	350		350		350		MHz	
t_{PLH}	CP to E_n	1.7	3.4	1.7	3.5	1.9	3.7	ns	Figures 1, 2
t_{PHL}									
t_{PZH}	OE to E_n (Cutoff to HIGH)	1.3	4.0	1.5	4.2	1.7	4.6	ns	Figures 1, 2
t_{PHZ}	OE to E_n (HIGH to Cutoff)	1.5	4.3	1.6	4.3	1.6	4.4	ns	Figures 1, 2
t_{PHZ}	DIR to E_n (HIGH to Cutoff)	1.6	4.1	1.6	4.1	1.7	4.3	ns	Figures 1, 2
t_{SET}	T_n to CP	1.0		1.0		1.0		ns	Figures 1, 2
t_{HOLD}	T_n to CP	1.7		1.7		1.9		ns	Figures 1, 2
$t_{PW(H)}$	Pulse Width CP	2.0		2.0		2.0		ns	Figures 1, 2
t_{TLH}	Transition Time	0.6	1.6	0.6	1.6	0.6	1.6	ns	Figures 1, 2
t_{THL}	20% to 80%, 80% to 20%								
t_{OSHL}	Maximum Skew Common Edge Output-to-Output Variation Data to Output Path		200		200		200	ps	PLCC Only (Note 9)
t_{OSLH}	Maximum Skew Common Edge Output-to-Output Variation Data to Output Path		200		200		200	ps	PLCC Only (Note 9)
t_{OST}	Maximum Skew Opposite Edge Output-to-Output Variation Data to Output Path		650		650		650	ps	PLCC Only (Note 9)
t_{PS}	Maximum Skew Pin (Signal) Transition Variation Data to Output Path		650		650		650	ps	PLCC Only (Note 9)

Note 9: Output-to-Output Skew is defined as the absolute value of the difference between the actual propagation delay for any outputs within the same packaged device. The specifications apply to any outputs switching in the same direction either HIGH-to-LOW (t_{OSHL}), or LOW-to-HIGH (t_{OSLH}), or in opposite directions both HL and LH (t_{OST}). Parameters t_{OST} and t_{PS} guaranteed by design.

PLCC and ECL-to-TTL AC Electrical Characteristics

$V_{EE} = -4.2V$ to $-5.7V$, $V_{TTL} = +4.5V$ to $+5.5V$, $C_L = 50$ pF

Symbol	Parameter	$T_C = 0^\circ C$		$T_C = 25^\circ C$		$T_C = 85^\circ C$		Units	Conditions
		Min	Max	Min	Max	Min	Max		
f_{MAX}	Max Toggle Frequency	125		125		125		MHz	
t_{PLH}	CP to T_n	3.1	7.0	3.1	7.0	3.3	7.5	ns	Figures 3, 4
t_{PHL}									
t_{PZH}	OE to T_n	3.4	8.25	3.7	8.75	4.0	9.5	ns	Figures 3, 5
t_{PZL}	(Enable Time)	3.8	9.0	4.0	9.0	4.3	9.75		
t_{PHZ}	OE to T_n	3.2	8.75	3.3	8.75	3.5	9.0	ns	Figures 3, 5
t_{PLZ}	(Disable Time)	3.0	7.5	3.4	8.5	4.1	9.75		
t_{PHZ}	DIR to T_n	2.7	8.0	2.8	8.5	3.1	8.75	ns	Figures 3, 6
t_{PLZ}	(Disable Time)	2.8	7.25	3.1	7.75	4.0	9.0		
t_{SET}	E_n to CP	1.0		1.0		1.0		ns	Figures 3, 4
t_{HOLD}	E_n to CP	2.0		2.0		2.5		ns	Figures 3, 4
$t_{PW(H)}$	Pulse Width CP	4.0		4.0		4.0		ns	Figures 3, 4
t_{OSHL}	Maximum Skew Common Edge Output-to-Output Variation Data to Output Path		600		600		600	ps	PLCC Only (Note 10)
t_{OSLH}	Maximum Skew Common Edge Output-to-Output Variation Data to Output Path		850		850		850	ps	PLCC Only (Note 10)
t_{OST}	Maximum Skew Opposite Edge Output-to-Output Variation Data to Output Path		1350		1350		1350	ps	PLCC Only (Note 10)
t_{PS}	Maximum Skew Pin (Signal) Transition Variation Data to Output Path		950		950		950	ps	PLCC Only (Note 10)

Note 10: Output-to-Output Skew is defined as the absolute value of the difference between the actual propagation delay for any outputs within the same packaged device. The specifications apply to any outputs switching in the same direction either HIGH-to-LOW (t_{OSHL}), or LOW-to-HIGH (t_{OSLH}), or in opposite directions both HL and LH (t_{OST}). Parameters t_{OST} and t_{PS} guaranteed by design.

Test Circuitry (TTL-to-ECL)

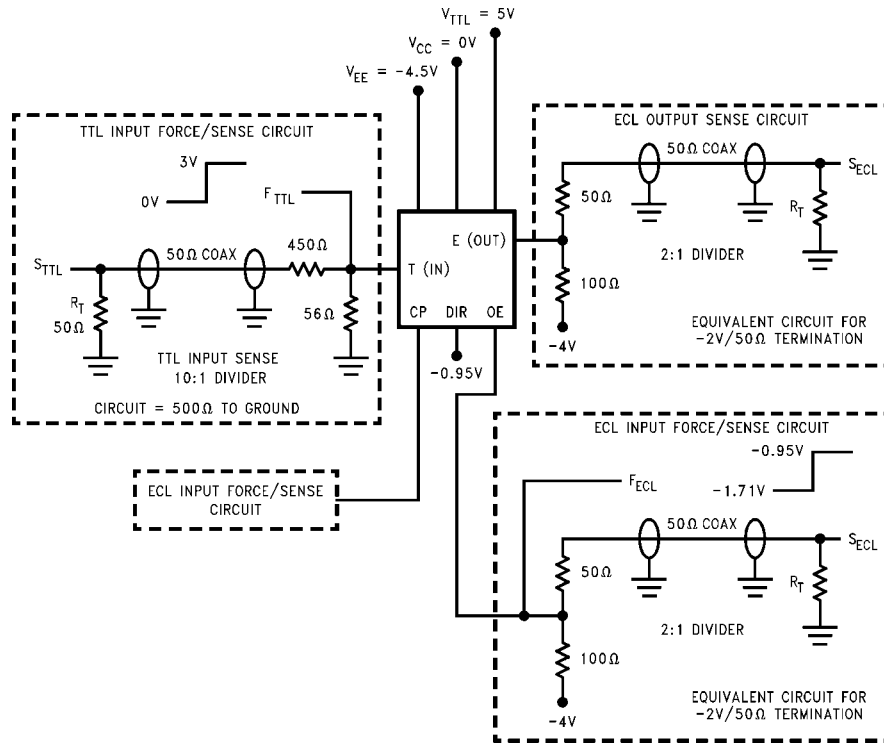

Note 11: $R_T = 50\Omega$ termination resistive load. When an input or output is being monitored by a scope, R_T is supplied by the scope's 50Ω input resistance. When an input or output is not being monitored, an external 50Ω resistance must be applied to serve as R_T .

Note 12: TTL and ECL force signals are brought to the DUT via 50Ω coax lines.

Note 13: V_{TTL} is decoupled to ground with $0.1\mu F$, V_{EE} is decoupled to ground with $0.01\mu F$ and V_{CC} is connected to ground.

FIGURE 1. TTL-to-ECL AC Test Circuit

Switching Waveforms (TTL-to-ECL)

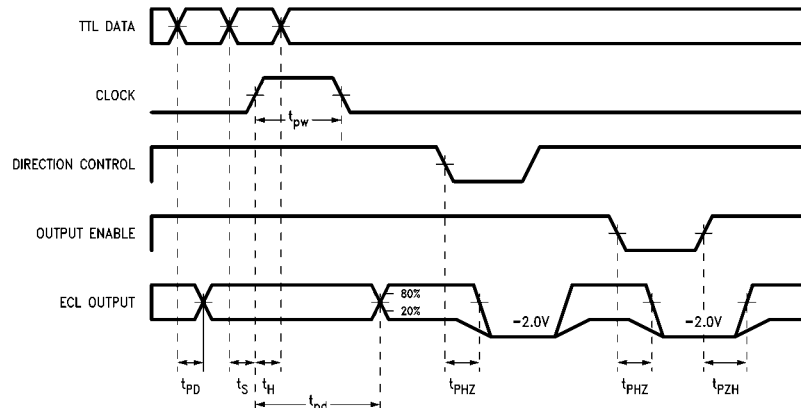
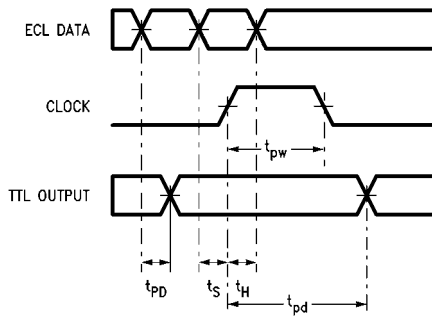

FIGURE 2. TTL to ECL Transition—Propagation Delay and Transition Times

Switching Waveforms (ECL-to-TTL)



Note: DIR is LOW, OE is HIGH

FIGURE 4. ECL-to-TTL Transition—Propagation Delay and Transition Times

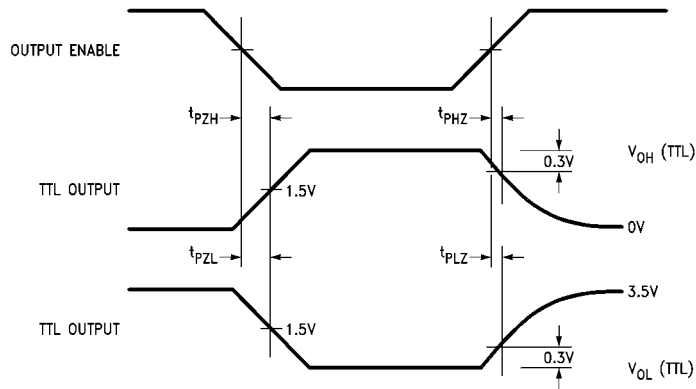

Note: DIR is LOW

FIGURE 5. ECL-to-TTL Transition, OE to TTL Output, Enable and Disable Times

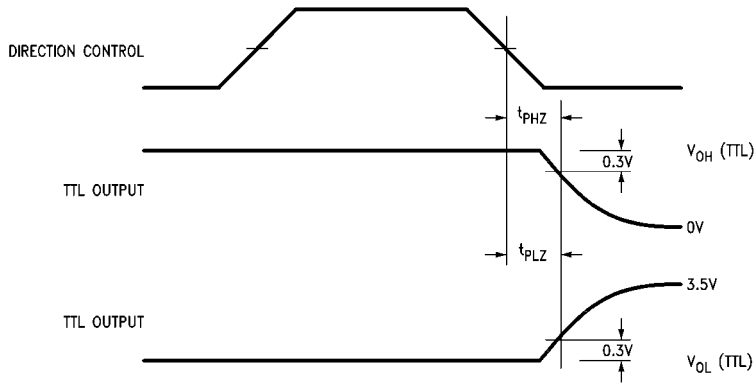

Note: OE is HIGH

FIGURE 6. ECL-to-TTL Transition, DIR to TTL Output, Disable Time

100329

Physical Dimensions inches (millimeters) unless otherwise noted

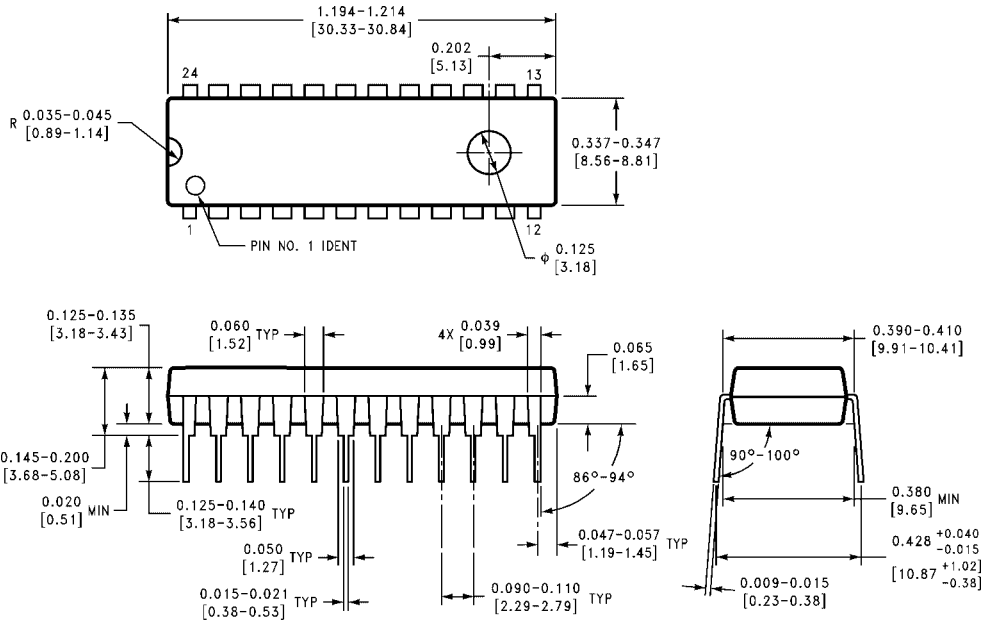

**24-Lead Plastic Dual-In-Line Package (PDIP), JEDEC MS-011, 0.400 Wide
Package Number N24E**

N24E (REV A)

Physical Dimensions inches (millimeters) unless otherwise noted (Continued)

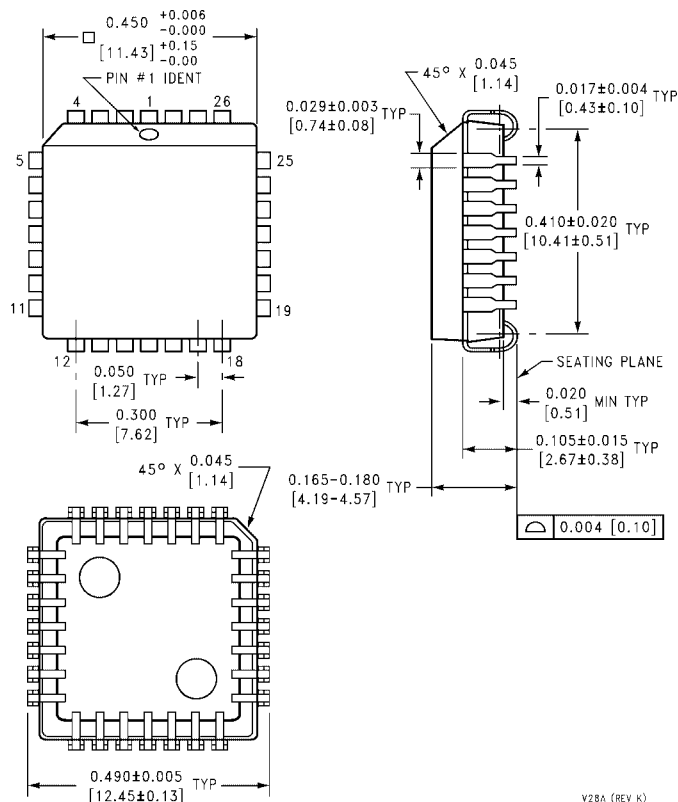

**28-Lead Plastic Lead Chip Carrier (PLCC), JEDEC MO-047, 0.450 Square
Package Number V28A**

Fairchild does not assume any responsibility for use of any circuitry described, no circuit patent licenses are implied and Fairchild reserves the right at any time without notice to change said circuitry and specifications.

LIFE SUPPORT POLICY

FAIRCHILD'S PRODUCTS ARE NOT AUTHORIZED FOR USE AS CRITICAL COMPONENTS IN LIFE SUPPORT DEVICES OR SYSTEMS WITHOUT THE EXPRESS WRITTEN APPROVAL OF THE PRESIDENT OF FAIRCHILD SEMICONDUCTOR CORPORATION. As used herein:

1. Life support devices or systems are devices or systems which, (a) are intended for surgical implant into the body, or (b) support or sustain life, and (c) whose failure to perform when properly used in accordance with instructions for use provided in the labeling, can be reasonably expected to result in a significant injury to the user.
2. A critical component in any component of a life support device or system whose failure to perform can be reasonably expected to cause the failure of the life support device or system, or to affect its safety or effectiveness.

www.fairchildsemi.com