

# 100329A

## Low Power Octal ECL/TTL Bidirectional Translator with Register

### General Description

The 100329A is an octal registered bidirectional translator designed to convert TTL logic levels to 100K ECL logic levels and vice versa. The direction of the translation is determined by the DIR input. A LOW on the output enable input (OE) holds the ECL outputs in a cut-off state and the TTL outputs at a high impedance level. The outputs change synchronously with the rising edge of the clock input (CP) even though only one output is enabled at the time.

The cut-off state is designed to be more negative than a normal ECL LOW level. This allows the output emitter-followers to turn off when the termination supply is  $-2.0V$ , presenting a high impedance to the data bus. This high impedance reduces the termination power and prevents loss of low state noise margin when several loads share the bus.

The 100329A is designed with FAST® TTL output buffers, featuring optimal DC drive and capable of quickly charging and discharging highly capacitive loads. All inputs have  $50\text{ k}\Omega$  pull-down resistors.

### Features

- Bidirectional translation
- ECL high impedance outputs
- Registered outputs
- FAST TTL outputs
- 3-STATE outputs
- Voltage compensated operating range =  $-4.2V$  to  $-5.7V$
- High drive IOS

### Ordering Code:

Commercial	Package Number	Package Description
100329APC	N24E	24-lead plastic dual in-line package

### Connection Diagrams

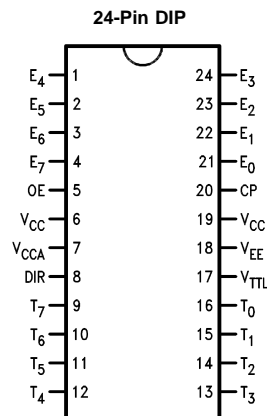

DS500047-2

## Logic Symbol

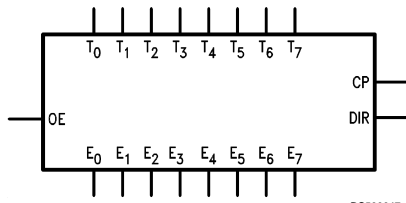

DS500047-1

## Pin Descriptions

Pin Names	Description
E <sub>0</sub> -E <sub>7</sub>	ECL Data I/O
T <sub>0</sub> -T <sub>7</sub>	TTL Data I/O
OE	Output Enable Input
CP	Clock Pulse Input (Active Rising Edge)
DIR	Direction Control Input

All pins function at 100K ECL levels except for T<sub>0</sub>-T<sub>7</sub>.

## Truth Tables

OE	DIR	CP	ECL Port	TTL Port	Notes
L	L	X	Input	Z	1, 3
L	H	X	LOW (Cut-Off)	Input	2, 3
H	L	[N]	L	L	1
H	L	[N]	H	H	1
H	L	L	X	NC	1, 3
H	H	[N]	L	L	2
H	H	[N]	H	H	2
H	H	L	NC	X	2, 3

H = HIGH Voltage Level  
 L = LOW Voltage Level  
 X = Don't Care  
 Z = High Impedance  
 [N] = LOW-to-HIGH Clock Transition  
 NC = No Change

## Functional Diagram

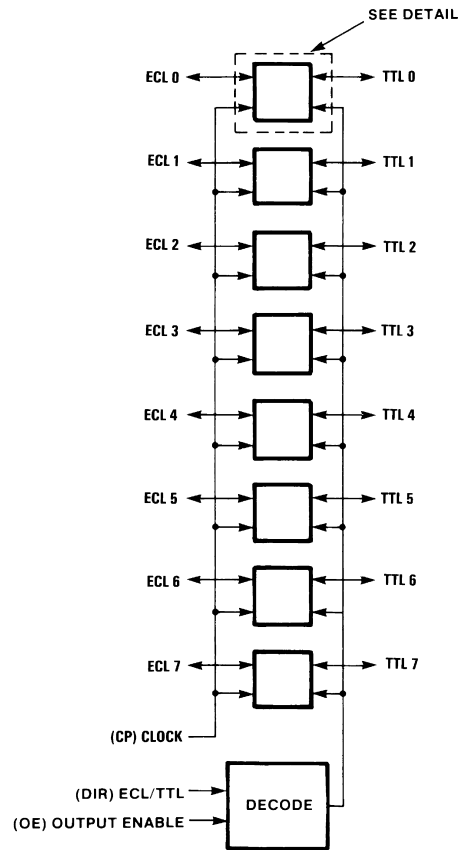

DS500047-5

Note: DIR and OE use ECL logic levels

## Functional Diagram (Continued)

### Detail

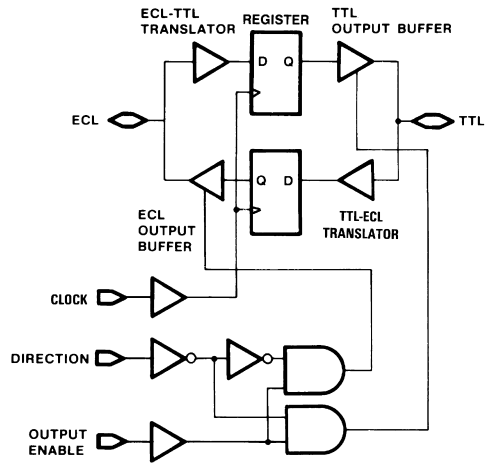

DS500047-6

**Note 1:** ECL input to TTL output mode.

**Note 2:** TTL input to ECL output mode.

**Note 3:** Retains data present before CP.

## Absolute Maximum Ratings (Note 4)

Storage Temperature ( $T_{STG}$ )	-65°C to +150°C
Maximum Junction Temperature ( $T_j$ )	
Plastic	+150°C
$V_{EE}$ Pin Potential to Ground Pin	-7.0V to +0.5V
$V_{TTL}$ Pin Potential to Ground Pin	-0.5V to +6.0V
ECL Input Voltage (DC)	$V_{EE}$ to +0.5V
ECL Output Current (DC Output HIGH)	-50 mA
TTL Input Voltage (Note 6)	-0.5V to +6.0V
TTL Input Current (Note 6)	-30 mA to +5.0 mA
Voltage Applied to Output in HIGH State	
3-STATE Output	-0.5V to +5.5V

Current Applied to TTL

Output in LOW State (Max)    Twice the Rated  $I_{OL}$  (mA)  
ESD (Note 5)     $\geq 2000V$

## Recommended Operating Conditions

Case Temperature ( $T_C$ )	
Commercial	0°C to +85°C
ECL Supply Voltage ( $V_{EE}$ )	-5.7V to -4.2V
TTL Supply Voltage ( $V_{TTL}$ )	+4.5V to +5.5V

**Note 4:** Absolute maximum ratings are those values beyond which the device may be damaged or have its useful life impaired. Functional operation under these conditions is not implied.

**Note 5:** ESD testing conforms to MIL-STD-883, Method 3015.

**Note 6:** Either voltage limit or current limit is sufficient to protect inputs.

## Commercial Version

### TTL-to-ECL DC Electrical Characteristics

$V_{EE} = -4.2V$  to  $-5.7V$ ,  $V_{CC} = V_{CCA} = GND$ ,  $T_C = 0^\circ C$  to  $+85^\circ C$ ,  $V_{TTL} = +4.5V$  to  $+5.5V$  (Note 7)

Symbol	Parameter	Min	Typ	Max	Units	Conditions
$V_{OH}$	Output HIGH Voltage	-1025	-955	-870	mV	$V_{IN} = V_{IH} (Max)$ or $V_{IL} (Min)$
$V_{OL}$	Output LOW Voltage	-1830	-1705	-1620	mV	Loading with 50Ω to -2V
	Cutoff Voltage		-2000	-1950	mV	OE or DIR LOW, $V_{IN} = V_{IH} (Max)$ or $V_{IL} (Min)$ Loading with 50Ω to -2V
$V_{OHC}$	Output HIGH Voltage Corner Point HIGH	-1035			mV	$V_{IN} = V_{IH} (Min)$ or $V_{IL} (Max)$ Loading with 50Ω to -2V
$V_{OLC}$	Output LOW Voltage Corner Point LOW			-1610	mV	
$V_{IH}$	Input HIGH Voltage	2.0		5.0	V	Over $V_{TTL}$ , $V_{EE}$ , $T_C$ Range
$V_{IL}$	Input LOW Voltage	0		0.8	V	Over $V_{TTL}$ , $V_{EE}$ , $T_C$ Range
$I_{IH}$	Input HIGH Current			70	μA	$V_{IN} = +2.7V$
	Breakdown Test			1.0	mA	$V_{IN} = +5.5V$
$I_{IL}$	Input LOW Current	-700			μA	$V_{IN} = +0.5V$
$V_{FCD}$	Input Clamp Diode Voltage	-1.2			V	$I_{IN} = -18 mA$
$I_{EE}$	$V_{EE}$ Supply Current				mA	LE LOW, OE and DIR HIGH Inputs Open
		-189		-94		$V_{EE} = -4.2V$ to $-4.8V$
		-199		-94		$V_{EE} = -4.2V$ to $-5.7V$

**Note 7:** The specified limits represent the "worst case" value for the parameter. Since these values normally occur at the temperature extremes, additional noise immunity and guardbanding can be achieved by decreasing the allowable system operating ranges. Conditions for testing shown in the tables are chosen to guarantee operation under "worst case" conditions.

### ECL-to-TTL DC Electrical Characteristics

$V_{EE} = -4.2V$  to  $-5.7V$ ,  $V_{CC} = V_{CCA} = GND$ ,  $T_C = 0^\circ C$  to  $+85^\circ C$ ,  $C_L = 50$  pF,  $V_{TTL} = +4.5V$  to  $+5.5V$  (Note 8)

Symbol	Parameter	Min	Typ	Max	Units	Conditions
$V_{OH}$	Output HIGH Voltage	2.7	3.1		V	$I_{OH} = -3$ mA, $V_{TTL} = 4.75V$ $I_{OH} = -3$ mA, $V_{TTL} = 4.50V$
		2.4	2.9		V	
$V_{OL}$	Output LOW Voltage		0.3	0.5	V	$I_{OL} = 24$ mA, $V_{TTL} = 4.50V$
$V_{IH}$	Input HIGH Voltage	-1165		-870	mV	Guaranteed HIGH Signal for All Inputs
$V_{IL}$	Input LOW Voltage	-1830		-1475	mV	Guaranteed LOW Signal for All Inputs
$I_{IH}$	Input HIGH Current			350	$\mu A$	$V_{IN} = V_{IH}$ (Max)
$I_{IL}$	Input LOW Current	0.50			$\mu A$	$V_{IN} = V_{IL}$ (Min)
$I_{OZHT}$	3-STATE Current Output HIGH			70	$\mu A$	$V_{OUT} = +2.7V$
$I_{OZLT}$	3-STATE Current Output LOW	-700			$\mu A$	$V_{OUT} = +0.5V$
$I_{OS}$	Output Short-Circuit Current	-225		-100	mA	$V_{OUT} = 0.0V$ , $V_{TTL} = +5.5V$
$I_{TTL}$	$V_{TTL}$ Supply Current			74	mA	TTL Outputs LOW
				49	mA	TTL Outputs HIGH
				67	mA	TTL Outputs in 3-STATE

### DIP TTL-to-ECL AC Electrical Characteristics

$V_{EE} = -4.2V$  to  $-5.7V$ ,  $V_{TTL} = +4.5V$  to  $+5.5V$ ,  $V_{CC} = V_{CCA} = GND$

Symbol	Parameter	$T_C = 0^\circ C$		$T_C = 25^\circ C$		$T_C = 85^\circ C$		Units	Conditions
		Min	Max	Min	Max	Min	Max		
$f_{max}$	Max Toggle Frequency	350		350		350		MHz	
$t_{PLH}$	CP to $E_n$	1.7	3.6	1.7	3.7	1.9	3.9	ns	Figures 1, 2
$t_{PHL}$									
$t_{PZH}$	OE to $E_n$ (Cutoff to HIGH)	1.3	4.2	1.5	4.4	1.7	4.8	ns	Figures 1, 2
$t_{PHZ}$	OE to $E_n$ (HIGH to Cutoff)	1.5	4.5	1.6	4.5	1.6	4.6	ns	Figures 1, 2
$t_{PHZ}$	DIR to $E_n$ (HIGH to Cutoff)	1.6	4.3	1.6	4.3	1.7	4.5	ns	Figures 1, 2
$t_{set}$	$T_n$ to CP	1.1		1.1		1.1		ns	Figures 1, 2
$t_{hold}$	$T_n$ to CP	1.7		1.7		1.9		ns	Figures 1, 2
$t_{pw(H)}$	Pulse Width CP	2.1		2.1		2.1		ns	Figures 1, 2
$t_{TLH}$	Transition Time	0.6	1.6	0.6	1.6	0.6	1.6	ns	Figures 1, 2
$t_{THL}$	20% to 80%, 80% to 20%								

**Note 8:** The specified limits represent the "worst case" value for the parameter. Since these values normally occur at the temperature extremes, additional noise immunity and guardbanding can be achieved by decreasing the allowable system operating ranges. Conditions for testing shown in the tables are chosen to guarantee operation under "worst case" conditions.

### DIP ECL-to-TTL AC Electrical Characteristics

$V_{EE} = -4.2V$  to  $-5.7V$ ,  $V_{TTL} = +4.5V$  to  $+5.5V$ ,  $V_{CC} = V_{CCA} = GND$ ,  $C_L = 50.pF$

Symbol	Parameter	$T_C = 0^\circ C$		$T_C = 25^\circ C$		$T_C = 85^\circ C$		Units	Conditions
		Min	Max	Min	Max	Min	Max		
$f_{max}$	Max Toggle Frequency	125		125		125		MHz	
$t_{PLH}$	CP to $T_n$	3.1	7.2	3.1	7.2	3.3	7.7	ns	Figures 3, 4
$t_{PHL}$									
$t_{PZH}$	OE to $T_n$	3.4	8.45	3.7	8.95	4.0	9.7	ns	Figures 3, 5
$t_{PZL}$	(Enable Time)	3.8	9.2	4.0	9.2	4.3	9.95		
$t_{PHZ}$	OE to $T_n$	3.2	8.95	3.3	8.95	3.5	9.2	ns	Figures 3, 5
$t_{PLZ}$	(Disable Time)	3.0	7.7	3.4	8.7	4.1	9.95		
$t_{PHZ}$	DIR to $T_n$	2.7	8.2	2.8	8.7	3.1	8.95	ns	Figures 3, 6
$t_{PLZ}$	(Disable Time)	2.8	7.45	3.1	7.95	4.0	9.2		
$t_{set}$	$E_n$ to CP	1.1		1.1		1.1		ns	Figures 3, 4
$t_{hold}$	$E_n$ to CP	2.1		2.1		2.6		ns	Figures 3, 4
$t_{pw(H)}$	Pulse Width CP	4.1		4.1		4.1		ns	Figures 3, 4

## ECL-to-TTL AC Electrical Characteristics

$V_{EE} = -4.2V$  to  $-5.7V$ ,  $V_{TTL} = +4.5V$  to  $+5.5V$ ,  $V_{CC} = V_{CCA} = GND$ ,  $C_L = 50$  pF

Symbol	Parameter	$T_C = -55^\circ C$		$T_C = 25^\circ C$		$T_C = +125^\circ C$		Units	Conditions	Notes
		Min	Max	Min	Max	Min	Max			
$f_{max}$	Max Toggle Frequency	200		200		100		MHz		(Note 12)
$t_{PLH}$	CP to $T_n$	3.1	8.0	3.1	7.3	3.3	8.0	ns	Figures 3, 4	(Notes 9, 10, 11)
$t_{PHL}$										
$t_{PZH}$	OE to $T_n$	3.4	9.1	3.7	9.0	4.0	10.1	ns	Figures 3, 5	
$t_{PZL}$	(Enable Time)	3.7	9.5	4.0	9.3	4.3	10.4			
$t_{PHZ}$	OE to $T_n$	3.2	10.0	3.3	9.0	3.5	9.3	ns	Figures 3, 5	
$t_{PLZ}$	(Disable Time)	3.0	9.8	3.4	8.8	4.1	10.4			
$t_{PHZ}$	DIR to $T_n$	2.6	9.5	2.8	8.8	3.0	9.0	ns	Figures 3, 6	
$t_{PLZ}$	(Disable Time)	2.7	8.7	3.1	8.0	4.0	9.6			
$t_{set}$	$E_n$ to CP	2.5		2.0		2.5		ns	Figures 3, 4	(Note 12)
$t_{hold}$	$E_n$ to CP	3.0		2.5		3.0		ns	Figures 3, 4	
$t_{pw(H)}$	Pulse Width CP	2.5		2.5		5.0		ns	Figures 3, 4	

**Note 9:** F100K 300 Series cold temperature testing is performed by temperature soaking (to guarantee junction temperature equals  $-55^\circ C$ ), then testing immediately after power-up. This provides "cold start" specs which can be considered a worst case condition at cold temperatures.

**Note 10:** Screen tested 100% on each device at  $+25^\circ C$  temperature latched only, Subgroup A9.

**Note 11:** Sample tested (Method 5005, Table I) on each manufactured lot at  $+25^\circ C$ , Subgroup A9, and at  $+125^\circ C$  and  $-55^\circ C$  temperatures, Subgroups A10 and A11.

**Note 12:** Not tested at  $+25^\circ C$ ,  $+125^\circ C$ , and  $-55^\circ C$  temperature (design characterization data).

## Test Circuitry (TTL-to-ECL)

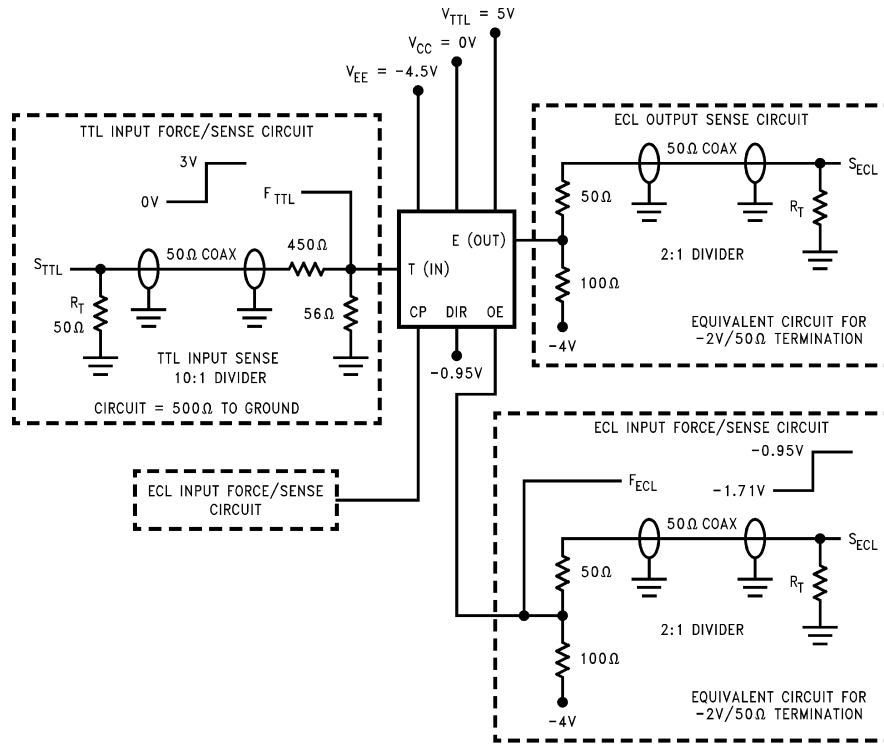

DS500047-7

**Note 13:**  $R_T = 50\Omega$  termination resistive load. When an input or output is being monitored by a scope,  $R_T$  is supplied by the scope's  $50\Omega$  input resistance. When an input or output is not being monitored, an external  $50\Omega$  resistance must be applied to serve as  $R_T$ .

**Note 14:** TTL and ECL force signals are brought to the DUT via  $50\Omega$  coax lines.

**Note 15:**  $V_{TTL}$  is decoupled to ground with  $0.1\ \mu\text{F}$ ,  $V_{EE}$  is decoupled to ground with  $0.01\ \mu\text{F}$  and  $V_{CC}$  is connected to ground.

**FIGURE 1. TTL-to-ECL AC Test Circuit**

## Switching Waveforms (TTL-to-ECL)

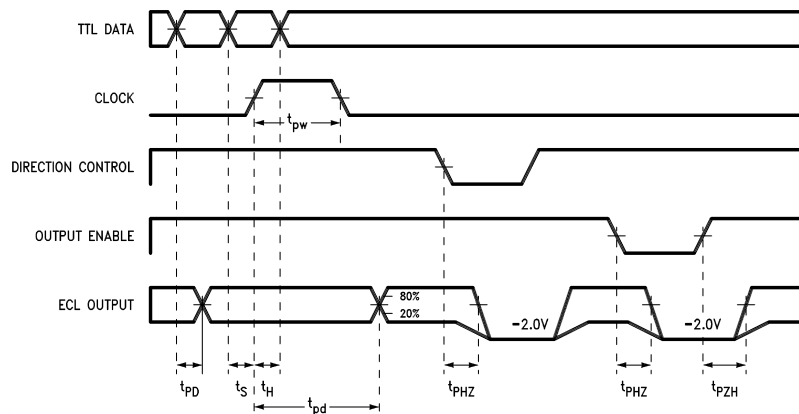

DS500047-9

**FIGURE 2. TTL to ECL Transition — Propagation Delay and Transition Times**

## Test Circuitry (ECL-to-TTL)

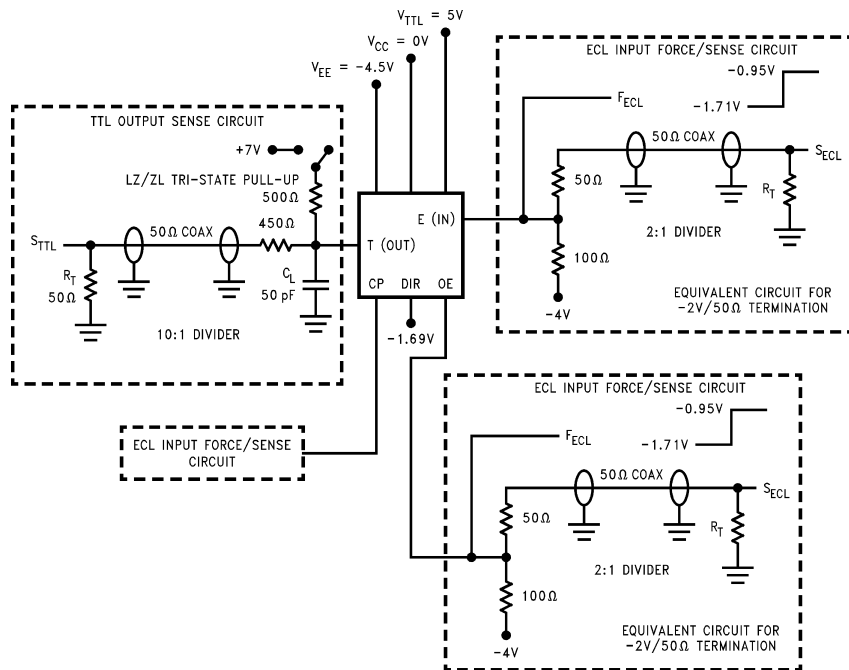

DS500047-10

**Note 16:**  $R_T = 50\Omega$  termination resistive load. When an input or output is being monitored by a scope,  $R_T$  is supplied by the scope's  $50\Omega$  input resistance. When an input or output is not being monitored, an external  $50\Omega$  resistance must be applied to serve as  $R_T$ .

**Note 17:** The TTL 3-STATE pull-up switch is connected to +7V only for LZ and LZ tests.

**Note 18:** TTL and ECL force signals are brought to the DUT via  $50\Omega$  coax lines.

**Note 19:**  $V_{TTL}$  is decoupled to ground with  $0.1\ \mu\text{F}$ ,  $V_{EE}$  is decoupled to ground with  $0.01\ \mu\text{F}$  and  $V_{CC}$  is connected to ground.

**FIGURE 3. ECL-to-TTL AC Test Circuit**

## Switching Waveforms (ECL-to-TTL)

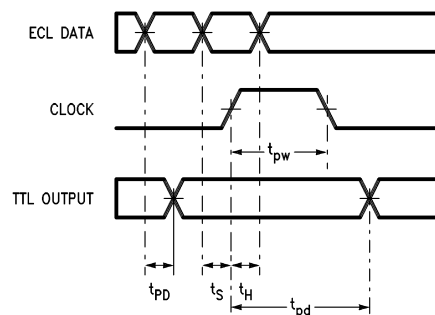

DS500047-11

**Note:** DIR is LOW, OE is HIGH

**FIGURE 4. ECL-to-TTL Transition — Propagation Delay and Transition Times**

## Switching Waveforms (ECL-to-TTL) (Continued)

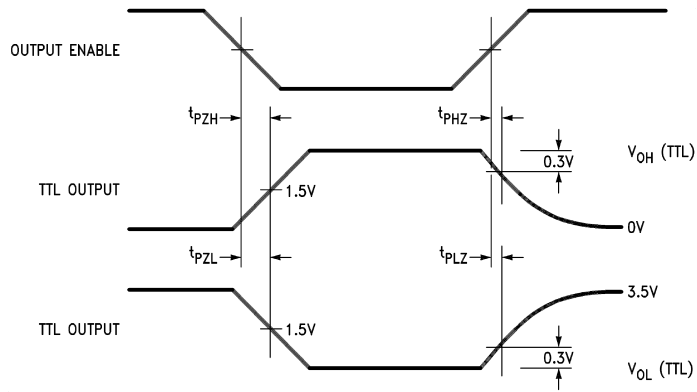

DS500047-12

Note: DIR is LOW

FIGURE 5. ECL-to-TTL Transition, OE to TTL Output, Enable and Disable Times

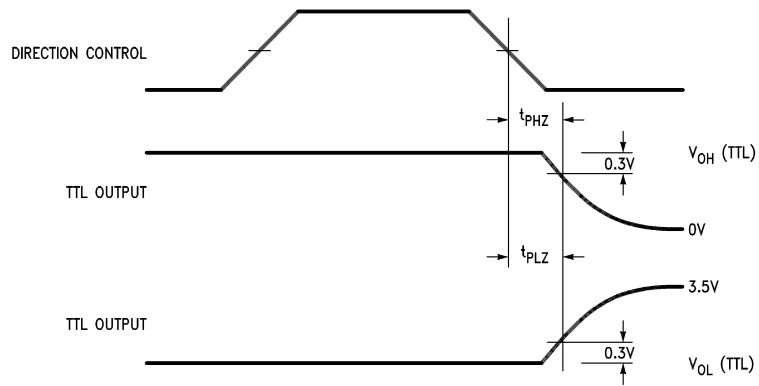

DS500047-13

Note: OE is HIGH

FIGURE 6. ECL-to-TTL Transition, DIR to TTL Output, Disable Time



**Physical Dimensions** inches (millimeters) unless otherwise noted

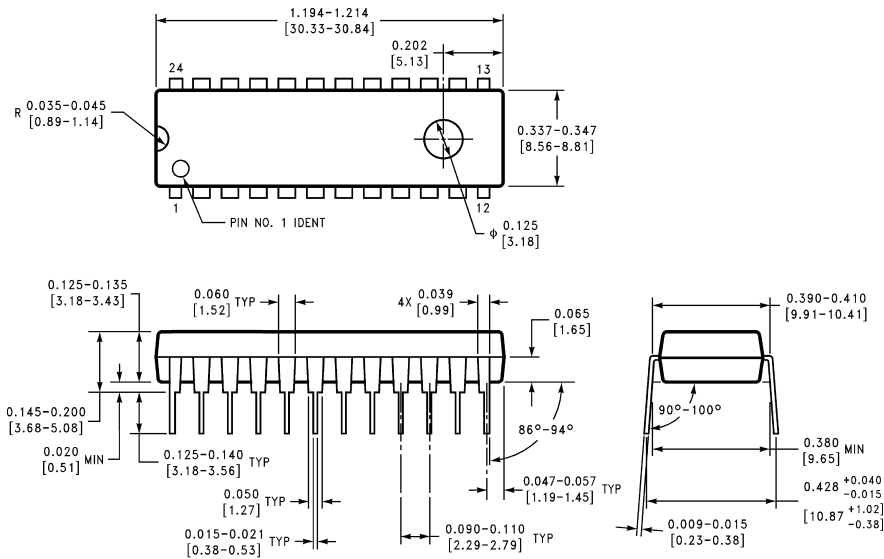

**24-Lead Plastic Dual-In-Line Package (P)**  
**Package Number N24E**

**LIFE SUPPORT POLICY**

FAIRCHILD'S PRODUCTS ARE NOT AUTHORIZED FOR USE AS CRITICAL COMPONENTS IN LIFE SUPPORT DEVICES OR SYSTEMS WITHOUT THE EXPRESS WRITTEN APPROVAL OF THE PRESIDENT OF FAIRCHILD SEMICONDUCTOR CORPORATION. As used herein:

1. Life support devices or systems are devices or systems which, (a) are intended for surgical implant into the body, or (b) support or sustain life, and (c) whose failure to perform when properly used in accordance with instructions for use provided in the labeling, can be reasonably expected to result in a significant injury to the user.
2. A critical component in any component of a life support device or system whose failure to perform can be reasonably expected to cause the failure of the life support device or system, or to affect its safety or effectiveness.

**Fairchild Semiconductor Corporation Americas**  
 Customer Response Center  
 Tel: 1-888-522-5372

**Fairchild Semiconductor Europe**  
 Fax: +49 (0) 1 80-530 85 86  
 Email: europe.support@nsc.com  
 Deutsch Tel: +49 (0) 8 141-35-0  
 English Tel: +44 (0) 1 793-85-68-56  
 Italy Tel: +39 (0) 2 57 5631

**Fairchild Semiconductor Hong Kong Ltd.**  
 13th Floor, Straight Block,  
 Ocean Centre, 5 Canton Rd.  
 Tsimshatsui, Kowloon  
 Hong Kong  
 Tel: +862 2737-7200  
 Fax: +852 2314-0061

**National Semiconductor Japan Ltd.**  
 Tel: 81-3-5620-6175  
 Fax: 81-3-5620-6179

[www.fairchildsemi.com](http://www.fairchildsemi.com)