

# 100350 Low Power Hex D-Type Latch

## General Description

The 100350 contains six D-type latches with true and complement outputs, a pair of common Enables ( $\bar{E}_a$  and  $\bar{E}_b$ ), and a common Master Reset (MR). A Q output follows its D input when both  $\bar{E}_a$  and  $\bar{E}_b$  are LOW. When either  $\bar{E}_a$  or  $\bar{E}_b$  (or both) are HIGH, a latch stores the last valid data present on its D input before  $\bar{E}_a$  or  $\bar{E}_b$  went HIGH. The MR input overrides all other inputs and makes the Q outputs LOW. All inputs have 50 k $\Omega$  pull-down resistors.

## Features

- 20% power reduction of the 100150
- 2000V ESD protection
- Pin/function compatible with 100150
- Voltage compensated operating range = -4.2V to -5.7V

## Ordering Code:

Order Number	Package Number	Package Description
100350PC	N24E	24-Lead Plastic Dual-In-Line Package (PDIP), JEDEC MS-011, 0.400 Wide
100350QC	V28A	28-Lead Plastic Lead Chip Carrier (PLCC), JEDEC MO-047, 0.450 Square

Devices also available in Tape and Reel. Specify by appending the suffix letter "X" to the ordering code.

## Logic Symbol

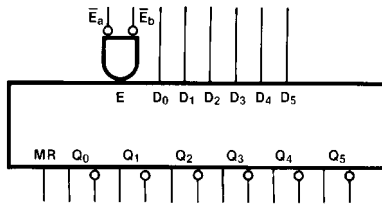

## Connection Diagrams

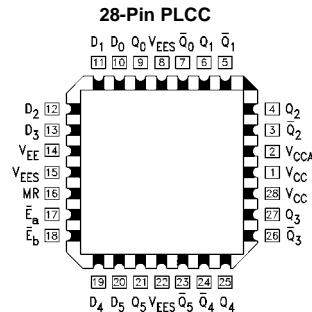
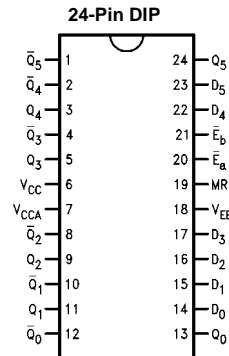

## Pin Descriptions

Pin Names	Description
D <sub>0</sub> -D <sub>5</sub>	Data Inputs
$\bar{E}_a$ , $\bar{E}_b$	Common Enable Inputs (Active LOW)
MR	Asynchronous Master Reset Input
Q <sub>0</sub> -Q <sub>5</sub>	Data Outputs
$\bar{Q}_0$ - $\bar{Q}_5$	Complementary Data Outputs

### Truth Tables

(Each Latch)

Latch Operation

Inputs				Outputs
$D_n$	$\bar{E}_a$	$\bar{E}_b$	MR	$Q_n$
L	L	L	L	L
H	L	L	L	H
X	H	X	L	Latched (Note 1)
X	X	H	L	Latched (Note 1)

Asynchronous Operation

Inputs				Outputs
$D_n$	$\bar{E}_a$	$\bar{E}_b$	MR	$Q_n$
X	X	X	H	L

H = HIGH Voltage Level

L = LOW Voltage Level

X = Don't Care

**Note 1:** Retains data present before  $\bar{E}$  positive transition

### Logic Diagram

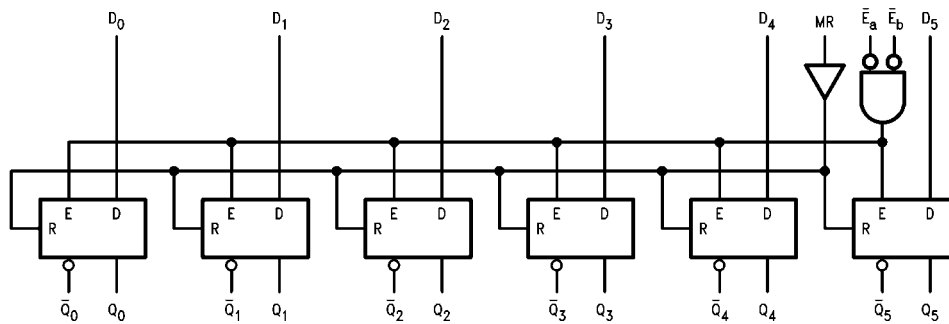

**Absolute Maximum Ratings**(Note 2)

Above which the useful life may be impaired.

Storage Temperature ( $T_{STG}$ )	-65°C to +150°C
Maximum Junction Temperature ( $T_J$ )	+150°C
$V_{EE}$ Pin Potential to Ground Pin	-7.0V to +0.5V
Input Voltage (DC)	$V_{EE}$ to +0.5V
Output Current (DC Output HIGH)	-50 mA
ESD (Note 3)	≥2000V

**Recommended Operating Conditions**

Case Temperature ( $T_C$ )	0°C to +85°C
Supply Voltage ( $V_{EE}$ )	-5.7V to -4.2V

**Note 2:** The "Absolute Maximum Ratings" are those values beyond which the safety of the device cannot be guaranteed. The device should not be operated at these limits. The parametric values defined in the Electrical Characteristics tables are not guaranteed at the absolute maximum rating. The "Recommended Operating Conditions" table will define the conditions for actual device operation.

**Note 3:** ESD testing conforms to MIL-STD-883, Method 3015.

**DC Electrical Characteristics** (Note 4) $V_{EE} = -4.5V$  to  $-5.7V$ ,  $V_{CC} = V_{CCA} = GND$ ,  $T_C = 0^\circ C$  to  $+85^\circ C$ 

Symbol	Parameter	Min	Typ	Max	Units	Conditions
$V_{OH}$	Output HIGH Voltage	-1025	-955	-870	mV	$V_{IN} = V_{IH} (Max)$ or $V_{IL} (Min)$ Loading with 50Ω to -2.0V
$V_{OL}$	Output LOW Voltage	-1830	-1705	-1620		
$V_{OHC}$	Output HIGH Voltage	-1035			mV	$V_{IN} = V_{IH} (Min)$ or $V_{IL} (Max)$ Loading with 50Ω to -2.0V
$V_{OLC}$	Output LOW Voltage			-1610		
$V_{IH}$	Input HIGH Voltage	-1165		-870	mV	Guaranteed HIGH Signal for All Inputs
$V_{IL}$	Input LOW Voltage	-1830		-1475	mV	Guaranteed LOW Signal for All Inputs
$I_{IL}$	Input LOW Current	0.50			μA	$V_{IN} = V_{IL} (Min)$
$I_{IH}$	Input HIGH Current MR $D_n$ $\bar{E}_a, \bar{E}_b$			240	μA	$V_{IN} = V_{IH} (Max)$
				240		
				240		
$I_{EE}$	Power Supply Current	-89		-44	mA	Inputs Open $V_{EE} = -4.2V$ to $-4.8V$ $V_{EE} = -4.2V$ to $-5.7V$
		-93		-44		

**Note 4:** The specified limits represent the "worst case" value for the parameter. Since these values normally occur at the temperature extremes, additional noise immunity and guard banding can be achieved by decreasing the allowable system operating ranges. Conditions for testing shown in the tables are chosen to guarantee operation under "worst case" conditions.

**DIP AC Electrical Characteristics** $V_{EE} = -4.2V$  to  $-5.7V$ ,  $V_{CC} = V_{CCA} = GND$ 

Symbol	Parameter	$T_C = 0^\circ C$		$T_C = +25^\circ C$		$T_C = +85^\circ C$		Units	Conditions
		Min	Max	Min	Max	Min	Max		
$t_{PLH}$	Propagation Delay $D_n$ to Output (Transparent Mode)	0.50	1.40	0.50	1.40	0.50	1.50	ns	Figures 1, 2
$t_{PHL}$									
$t_{PLH}$	Propagation Delay $\bar{E}_a, \bar{E}_b$ to Output	0.75	1.85	0.75	1.85	0.75	2.05	ns	Figures 1, 3
$t_{PHL}$									
$t_{PLH}$	Propagation Delay MR to Output	0.90	2.10	0.90	2.10	0.90	2.10	ns	Figures 1, 3
$t_{PHL}$									
$t_{TLH}$	Transition Time 20% to 80%, 80% to 20%	0.35	1.30	0.35	1.30	0.35	1.30	ns	Figures 1, 2
$t_{THL}$									
$t_S$	Setup Time $D_0-D_5$	1.00		1.00		1.00		ns	Figures 3, 4
	MR (Release Time)								
$t_H$	Hold Time, $D_0-D_5$	0.40		0.40		0.40		ns	Figure 4
$t_{PW(L)}$	Pulse Width LOW $\bar{E}_a, \bar{E}_b$	2.00		2.00		2.00		ns	Figure 2
$t_{PW(H)}$	Pulse Width HIGH, MR	2.00		2.00		2.00		ns	Figure 3

## PLCC AC Electrical Characteristics

$V_{EE} = -4.2V$  to  $-5.7V$ ,  $V_{CC} = V_{CCA} = GND$

Symbol	Parameter	$T_C = 0^\circ C$		$T_C = +25^\circ C$		$T_C = +85^\circ C$		Units	Conditions
		Min	Max	Min	Max	Min	Max		
$t_{PLH}$ $t_{PHL}$	Propagation Delay $D_n$ to Output (Transparent Mode)	0.50	1.20	0.50	1.20	0.50	1.30	ns	Figures 1, 2
$t_{PLH}$ $t_{PHL}$	Propagation Delay $\bar{E}_a, \bar{E}_b$ to Output	0.75	1.65	0.75	1.65	0.75	1.85	ns	
$t_{PLH}$ $t_{PHL}$	Propagation Delay MR to Output	0.90	1.90	0.90	1.90	0.90	1.90	ns	Figures 1, 3
$t_{TLH}$ $t_{THL}$	Transition Time 20% to 80%, 80% to 20%	0.35	1.10	0.35	1.10	0.35	1.10	ns	Figures 1, 2
$t_S$	Setup Time $D_0-D_5$ MR (Release Time)	0.90		0.90		0.90		ns	Figures 3, 4
$t_H$	Hold Time, $D_0-D_5$	0.30		0.30		0.30		ns	Figure 4
$t_{PW(L)}$	Pulse Width LOW $\bar{E}_a, \bar{E}_b$	2.00		2.00		2.00		ns	Figure 2
$t_{PW(H)}$	Pulse Width HIGH, MR	2.00		2.00		2.00		ns	Figure 3

### Test Circuit

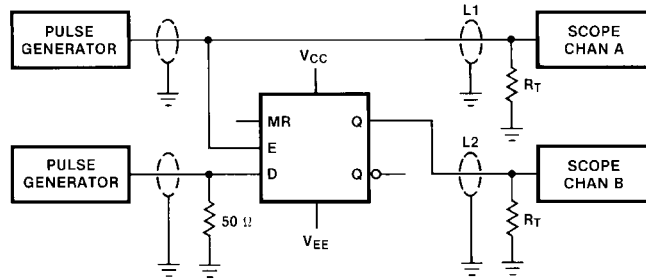

#### Note:

- $V_{CC}, V_{CCA} = +2V, V_{EE} = -2.5V$
- L1 and L2 = equal length 50 $\Omega$  impedance lines
- $R_T = 50\Omega$  terminator internal to scope
- Decoupling 0.1  $\mu F$  from GND to  $V_{CC}$  and  $V_{EE}$
- All unused outputs are loaded with 50 $\Omega$  to GND
- $C_L$  = Fixture and stray capacitance  $\leq 3$  pF

FIGURE 1. AC Test Circuit

### Switching Waveforms

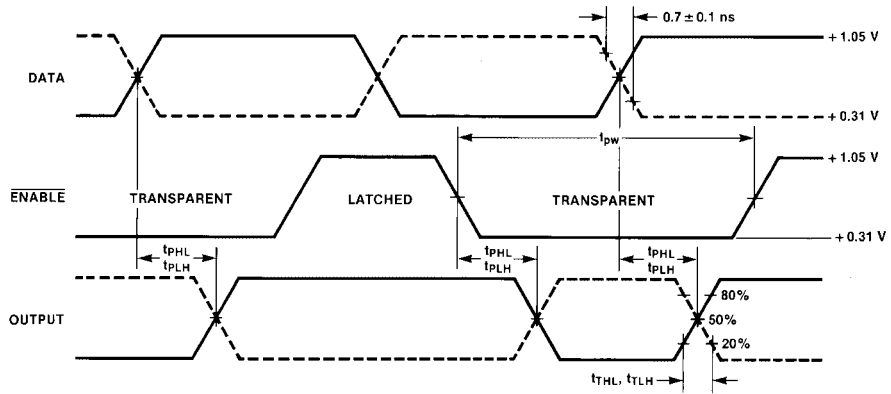

FIGURE 2. Enable Timing

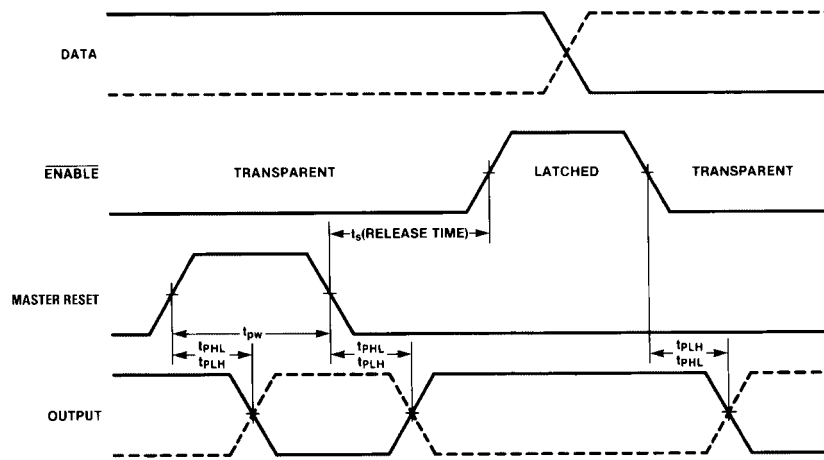
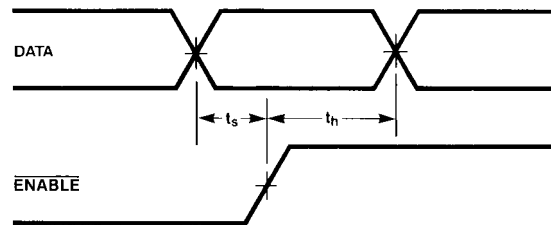

FIGURE 3. Reset Timing



**Notes:**

$t_S$  is the minimum time before the transition of the enable that information must be present at the data input.

$t_H$  is the minimum time after the transition of the enable that information must remain unchanged at the data input.

FIGURE 4. Data Setup and Hold Time

100350

**Physical Dimensions** inches (millimeters) unless otherwise noted

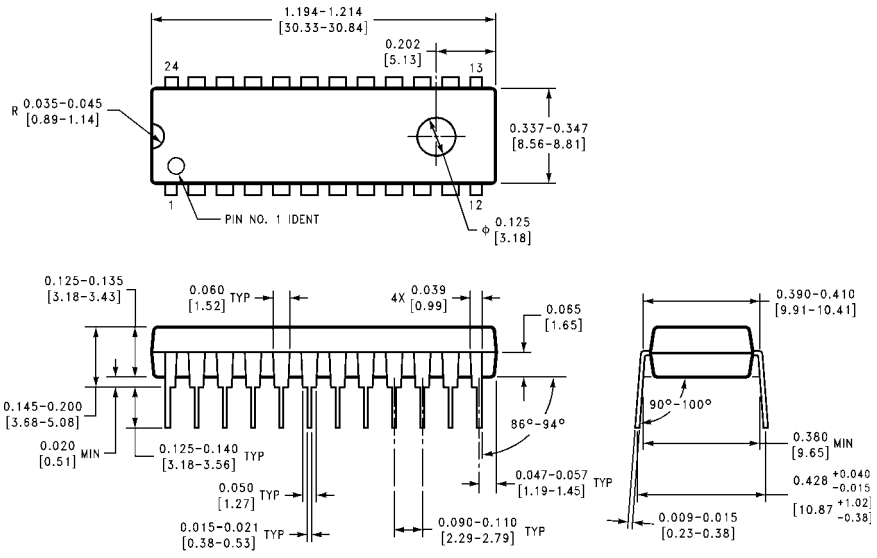

**24-Lead Plastic Dual-In-Line Package (PDIP), JEDEC MS-011, 0.400 Wide  
Package Number N24E**

N24E (REV A)

**Physical Dimensions** inches (millimeters) unless otherwise noted (Continued)

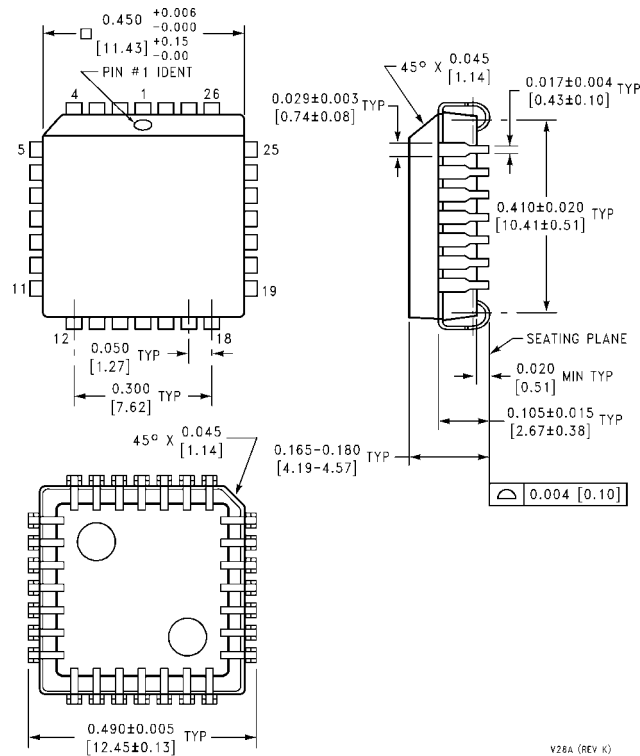

**28-Lead Plastic Lead Chip Carrier (PLCC), JEDEC MO-047, 0.450 Square Package Number V28A**

V28A (REV K)

Fairchild does not assume any responsibility for use of any circuitry described, no circuit patent licenses are implied and Fairchild reserves the right at any time without notice to change said circuitry and specifications.

**LIFE SUPPORT POLICY**

FAIRCHILD'S PRODUCTS ARE NOT AUTHORIZED FOR USE AS CRITICAL COMPONENTS IN LIFE SUPPORT DEVICES OR SYSTEMS WITHOUT THE EXPRESS WRITTEN APPROVAL OF THE PRESIDENT OF FAIRCHILD SEMICONDUCTOR CORPORATION. As used herein:

1. Life support devices or systems are devices or systems which, (a) are intended for surgical implant into the body, or (b) support or sustain life, and (c) whose failure to perform when properly used in accordance with instructions for use provided in the labeling, can be reasonably expected to result in a significant injury to the user.
2. A critical component in any component of a life support device or system whose failure to perform can be reasonably expected to cause the failure of the life support device or system, or to affect its safety or effectiveness.

[www.fairchildsemi.com](http://www.fairchildsemi.com)