

100364 Low Power 16-Input Multiplexer

General Description

The 100364 is a 16-input multiplexer. Data paths are controlled by four Select lines (S_0 – S_3). Their decoding is shown in the Truth Table. Output data polarity is the same as the selected input data. All inputs have 50 k Ω pull-down resistors.

Features

- 35% power reduction of the 100164
- 2000V ESD protection
- Pin/function compatible with 100164
- Voltage compensated operating range = $-4.2V$ to $-5.7V$
- Available to industrial grade temperature range

Ordering Code:

Order Number	Package Number	Package Description
100364PC	N24E	24-Lead Plastic Dual-In-Line Package (PDIP), JEDEC MS-011, 0.400 Wide
100364QC	V28A	28-Lead Plastic Lead Chip Carrier (PLCC), JEDEC MO-047, 0.450 Square
100364QI	V28A	28-Lead Plastic Lead Chip Carrier (PLCC), JEDEC MO-047, 0.450 Square Industrial Temperature Range ($-40^{\circ}C$ to $+85^{\circ}C$)

Devices also available in Tape and Reel. Specify by appending the suffix letter "X" to the ordering code.

Logic Symbol

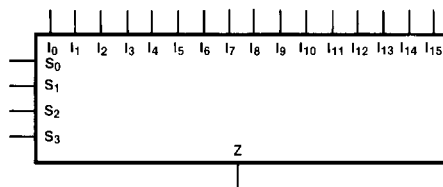

Connection Diagrams

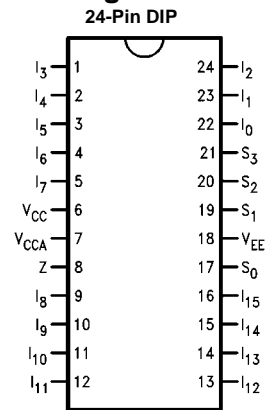

Pin Descriptions

Pin Names	Description
I_0 – I_{15}	Data Inputs
S_0 – S_3	Select Inputs
Z	Data Output

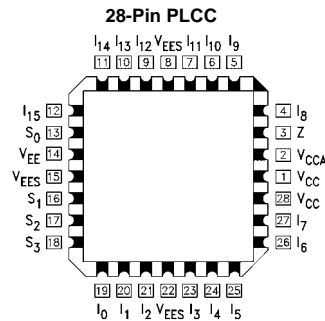

Truth Table

Select Inputs				Output
S ₀	S ₁	S ₂	S ₃	Z
L	L	L	L	I ₀
H	L	L	L	I ₁
L	H	L	L	I ₂
H	H	L	L	I ₃
L	L	H	L	I ₄
H	L	H	L	I ₅
L	H	H	L	I ₆
H	H	H	L	I ₇
L	L	L	H	I ₈
H	L	L	H	I ₉
L	H	L	H	I ₁₀
H	H	L	H	I ₁₁
L	L	H	H	I ₁₂
H	L	H	H	I ₁₃
L	H	H	H	I ₁₄
H	H	H	H	I ₁₅

H = HIGH Voltage Level
L = LOW Voltage Level

Logic Diagram

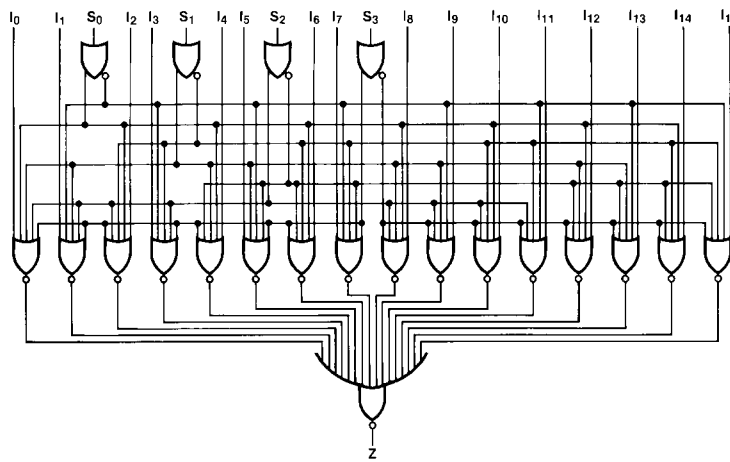

Absolute Maximum Ratings(Note 1)

Storage Temperature (T_{STG})	-65°C to +150°C
Maximum Junction Temperature (T_J)	+150°C
Pin Potential to Ground Pin (V_{EE})	-7.0V to +0.5V
Input Voltage (DC)	V_{EE} to +0.5V
Output Current (DC Output HIGH)	-50 mA
ESD (Note 2)	≥ 2000V

Recommended Operating Conditions

Case Temperature (T_C)	Commercial	0°C to +85°C
	Industrial	-40°C to +85°C
Supply Voltage (V_{EE})		-5.7V to -4.2V

Note 1: The "Absolute Maximum Ratings" are those values beyond which the safety of the device cannot be guaranteed. The device should not be operated at these limits. The parametric values defined in the Electrical Characteristics tables are not guaranteed at the absolute maximum rating. The "Recommended Operating Conditions" table will define the conditions for actual device operation.

Note 2: ESD testing conforms to MIL-STD-883, Method 3015.

Commercial Version**DC Electrical Characteristics** (Note 3)

$V_{EE} = -4.2V$ to $-5.7V$, $V_{CC} = V_{CCA} = GND$, $T_C = 0^\circ C$ to $+85^\circ C$

Symbol	Parameter	Min	Typ	Max	Units	Conditions	
V_{OH}	Output HIGH Voltage	-1025	-955	-870	mV	$V_{IN} = V_{IH}$ (Max)	Loading with 50Ω to -2.0V
V_{OL}	Output LOW Voltage	-1830	-1705	-1620	mV	or V_{IL} (Min)	
V_{OHC}	Output HIGH Voltage	-1035			mV	$V_{IN} = V_{IH}$ (Min)	Loading with 50Ω to -2.0V
V_{OLC}	Output LOW Voltage			-1610	mV	or V_{IL} (Max)	
V_{IH}	Input HIGH Voltage	-1165		-870	mV	Guaranteed HIGH Signal for All Inputs	
V_{IL}	Input LOW Voltage	-1830		-1475	mV	Guaranteed LOW Signal for All Inputs	
I_{IL}	Input LOW Current	0.5			μA	$V_{IN} = V_{IL}$ (Min)	
I_{IH}	Input HIGH Current			300	μA	$V_{IN} = V_{IH}$ (Max)	
I_{EE}	Power Supply Current	-89		-45	mA	Inputs OPEN	

Note 3: The specified limits represent the "worst case" value for the parameter. Since these values normally occur at the temperature extremes, additional noise immunity and guardbanding can be achieved by decreasing the allowable system operating ranges. Conditions for testing shown in the tables are chosen to guarantee operate under "worst case" conditions.

DIP AC Electrical Characteristics

$V_{EE} = -4.2V$ to $-5.7V$, $V_{CC} = V_{CCA} = GND$

Symbol	Parameter	$T_C = 0^\circ C$		$T_C = +25^\circ C$		$T_C = +85^\circ C$		Units	Conditions
		Min	Max	Min	Max	Min	Max		
t_{PLH}	Propagation Delay	0.90	2.00	0.90	2.00	0.90	2.10	ns	Figures 1, 2
t_{PHL}	I_0 - I_{15} to Output								
t_{PLH}	Propagation Delay	1.40	2.80	1.40	2.80	1.50	2.90		
t_{PHL}	S_0 , S_1 to Output								
t_{PLH}	Propagation Delay	1.00	2.20	1.00	2.20	1.10	2.40		
t_{PHL}	S_2 , S_3 to Output								
t_{TLH}	Transition Time	0.35	1.20	0.35	1.20	0.35	1.20		
t_{THL}	20% to 80%, 80% to 20%								

Commercial Version (Continued) PLCC AC Electrical Characteristics

 $V_{EE} = -4.2V$ to $-5.7V$, $V_{CC} = V_{CCA} = GND$

Symbol	Parameter	$T_C = 0^\circ C$		$T_C = +25^\circ C$		$T_C = +85^\circ C$		Units	Conditions
		Min	Max	Min	Max	Min	Max		
t_{PLH} t_{PHL}	Propagation Delay I_0 - I_{15} to Output	0.90	1.80	0.90	1.80	0.90	1.90	ns	Figures 1, 2
t_{PLH} t_{PHL}	Propagation Delay S_0, S_1 to Output	1.40	2.60	1.40	2.60	1.50	2.70	ns	
t_{PLH} t_{PHL}	Propagation Delay S_2, S_3 to Output	1.00	2.00	1.00	2.00	1.10	2.20	ns	
t_{TLH} t_{THL}	Transition Time 20% to 80%, 80% to 20%	0.35	1.10	0.35	1.10	0.35	1.10	ns	

Industrial Version

PLCC DC Electrical Characteristics (Note 4)

 $V_{EE} = -4.2V$ to $-5.7V$, $V_{CC} = V_{CCA} = GND$, $T_C = -40^\circ C$ to $+85^\circ C$

Symbol	Parameter	$T_C = -40^\circ C$		$T_C = 0^\circ C$ to $+85^\circ C$		Units	Conditions
		Min	Max	Min	Max		
V_{OH}	Output HIGH Voltage	-1085	-870	-1025	-870	mV	$V_{IN} = V_{IH}$ (Max) Loading with 50Ω to $-2.0V$
V_{OL}	Output LOW Voltage	-1830	-1575	-1830	-1620	mV	or V_{IL} (Min)
V_{OHC}	Output HIGH Voltage	-1095		-1035		mV	$V_{IN} = V_{IH}$ (Min)
V_{OLC}	Output LOW Voltage		-1565		-1610	mV	or V_{IL} (Max) Loading with 50Ω to $-2.0V$
V_{IH}	Input HIGH Voltage	-1170	-870	-1165	-870	mV	Guaranteed HIGH Signal for All Inputs
V_{IL}	Input LOW Voltage	-1830	-1480	-1830	-1475	mV	Guaranteed LOW Signal for All Inputs
I_{IL}	Input LOW Current	0.5		0.5		μA	$V_{IN} = V_{IL}$ (Min)
I_{IH}	Input HIGH Current		325		325	μA	$V_{IN} = V_{IH}$ (Max)
I_{EE}	Power Supply Current	-89	-45	-89	-45	mA	Inputs OPEN

Note 4: The specified limits represent the "worst case" value for the parameter. Since these values normally occur at the temperature extremes, additional noise immunity and guardbanding can be achieved by decreasing the allowable system operating ranges. Conditions for testing shown in the tables are chosen to guarantee operation under "worst case" conditions.

PLCC AC Electrical Characteristics

 $V_{EE} = -4.2V$ to $-5.7V$, $V_{CC} = V_{CCA} = GND$

Symbol	Parameter	$T_C = -40^\circ C$		$T_C = +25^\circ C$		$T_C = +85^\circ C$		Units	Conditions
		Min	Max	Min	Max	Min	Max		
t_{PLH} t_{PHL}	Propagation Delay I_0 - I_{15} to Output	0.90	1.80	0.90	1.80	0.90	1.90	ns	Figures 1 Figure 2
t_{PLH} t_{PHL}	Propagation Delay S_0, S_1 to Output	1.20	2.60	1.40	2.60	1.50	2.70	ns	
t_{PLH} t_{PHL}	Propagation Delay S_2, S_3 to Output	0.80	2.10	1.00	2.00	1.10	2.20	ns	
t_{TLH} t_{THL}	Transition Time 20% to 80%, 80% to 20%	0.20	1.20	0.35	1.10	0.35	1.10	ns	

Test Circuit

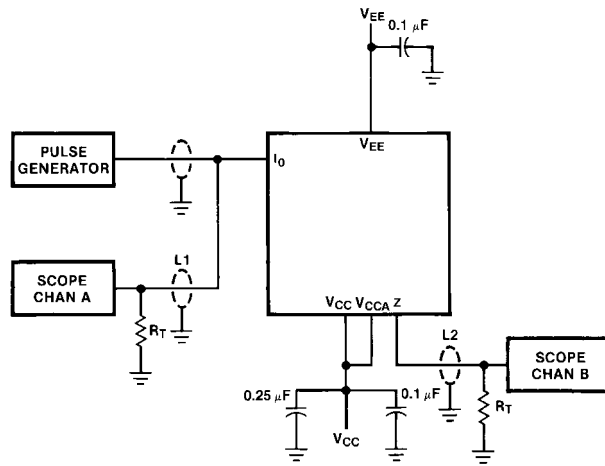

Note:
 $V_{CC}, V_{CCA} = +2V, V_{EE} = -2.5V$
 $L1$ and $L2$ = Equal length 50Ω impedance lines
 $R_T = 50\Omega$ terminator internal to scope
 Decoupling $0.1 \mu F$ from GND to V_{CC} and V_{EE}
 All unused outputs are loaded with 50Ω to GND
 C_L = Fixture and stray capacitance ≤ 3 pF

FIGURE 1. AC Test Circuit

Switching Waveforms

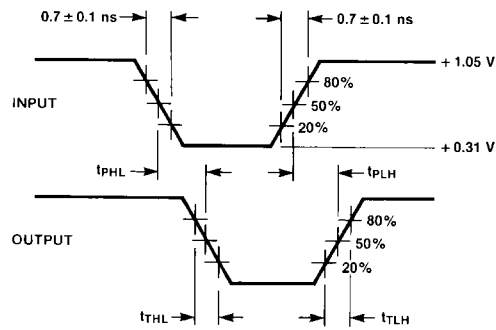
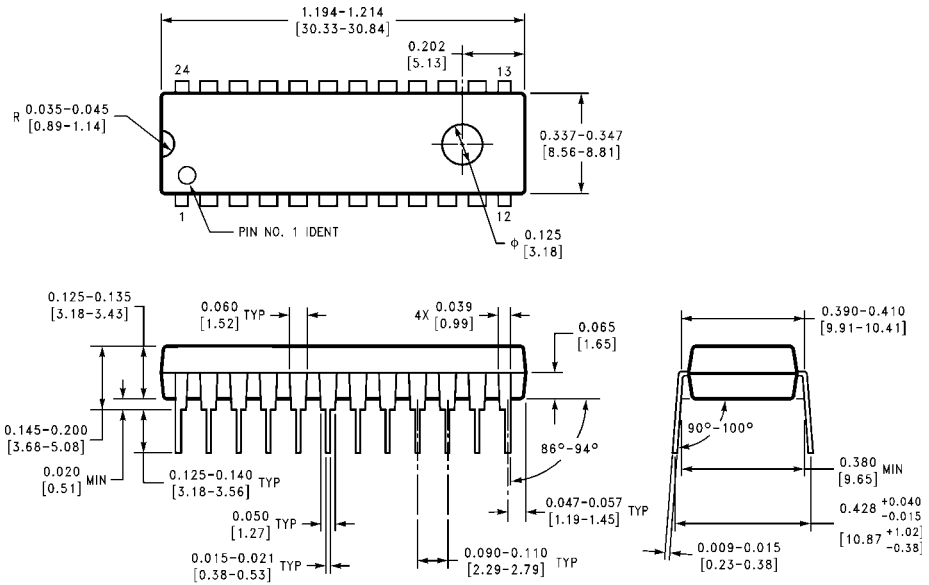

FIGURE 2. Propagation Delay and Transition Times

100364

Physical Dimensions inches (millimeters) unless otherwise noted



N24E (REV A)

24-Lead Plastic Dual-In-Line Package (PDIP), JEDEC MS-011, 0.400 Wide Package Number N24E

Physical Dimensions inches (millimeters) unless otherwise noted (Continued)

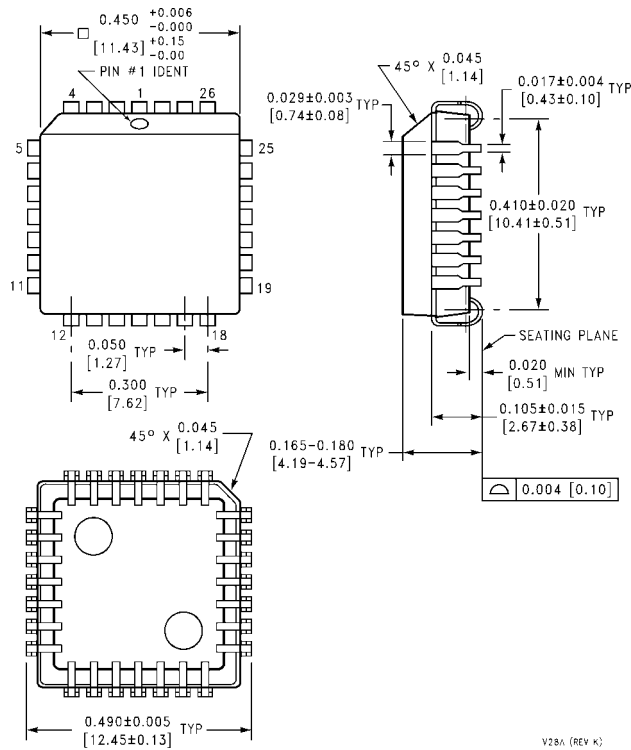

28-Lead Plastic Lead Chip Carrier (PLCC), JEDEC MO-047, 0.450 Square Package Number V28A

Fairchild does not assume any responsibility for use of any circuitry described, no circuit patent licenses are implied and Fairchild reserves the right at any time without notice to change said circuitry and specifications.

LIFE SUPPORT POLICY

FAIRCHILD'S PRODUCTS ARE NOT AUTHORIZED FOR USE AS CRITICAL COMPONENTS IN LIFE SUPPORT DEVICES OR SYSTEMS WITHOUT THE EXPRESS WRITTEN APPROVAL OF THE PRESIDENT OF FAIRCHILD SEMICONDUCTOR CORPORATION. As used herein:

1. Life support devices or systems are devices or systems which, (a) are intended for surgical implant into the body, or (b) support or sustain life, and (c) whose failure to perform when properly used in accordance with instructions for use provided in the labeling, can be reasonably expected to result in a significant injury to the user.
2. A critical component in any component of a life support device or system whose failure to perform can be reasonably expected to cause the failure of the life support device or system, or to affect its safety or effectiveness.

www.fairchildsemi.com