

# 100370 Low Power Universal Demultiplexer/Decoder

## General Description

The 100370 universal demultiplexer/decoder functions as either a dual 1-of-4 decoder or as a single 1-of-8 decoder, depending on the signal applied to the Mode Control (M) input. In the dual mode, each half has a pair of active-LOW Enable ( $\bar{E}$ ) inputs. Pin assignments for the  $\bar{E}$  inputs are such that in the 1-of-8 mode they can easily be tied together in pairs to provide two active-LOW enables ( $\bar{E}_{1a}$  to  $\bar{E}_{1b}$ ,  $\bar{E}_{2a}$  to  $\bar{E}_{2b}$ ). Signals applied to auxiliary inputs  $H_a$ ,  $H_b$  and  $H_c$  determine whether the outputs are active HIGH or active LOW. In the dual 1-of-4 mode the Address inputs are  $A_{0a}$ ,  $A_{1a}$  and  $A_{0b}$ ,  $A_{1b}$  with  $A_{2a}$  unused (i.e., left open, tied to  $V_{EE}$  or with LOW signal applied). In the 1-of-8 mode, the Address inputs are  $A_{0a}$ ,  $A_{1a}$ ,  $A_{2a}$  with  $A_{0b}$  and  $A_{1b}$  LOW or OPEN. All inputs have 50 k $\Omega$  pull-down resistors.

## Features

- 35% power reduction of the 100170
- 2000V ESD protection
- Pin/function compatible with 100170
- Voltage compensated operating range = -4.2V to -5.7V

## Ordering Code:

Order Number	Package Number	Package Description
100370PC	N24E	24-Lead Plastic Dual-In-Line Package (PDIP), JEDEC MS-011, 0.400 Wide
100370QC	V28A	28-Lead Plastic Lead Chip Carrier (PLCC), JEDEC MO-047, 0.450 Square
100370QI	V28A	28-Lead Plastic Lead Chip Carrier (PLCC), JEDEC MO-047, 0.450 Square Industrial Temperature Range (-40°C to +85°C)

Devices also available in Tape and Reel. Specify by appending the suffix letter "X" to the ordering code.

## Connection Diagrams

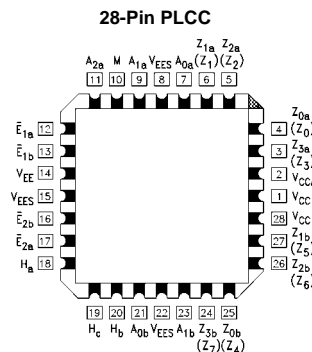
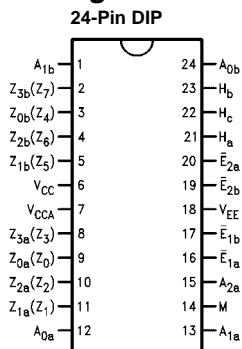

### Logic Symbols

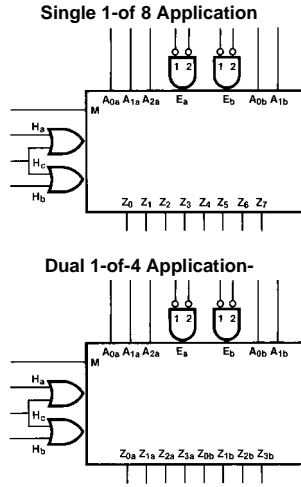

### Pin Descriptions

Pin Names	Description
$A_{na}, A_{nb}$	Address Inputs
$\bar{E}_{na}, \bar{E}_{nb}$	Enable Inputs
M	Mode Control Input
$H_a$	$Z_0-Z_3$ ( $\bar{Z}_{0a}-\bar{Z}_{3a}$ ) Polarity Select Input
$H_b$	$Z_4-Z_7$ ( $\bar{Z}_{0b}-\bar{Z}_{3b}$ ) Polarity Select Input
$H_c$	Common Polarity Select Input
$Z_0-Z_7$	Single 1-of-8 Data Outputs
$Z_{na}, Z_{nb}$	Dual 1-of-4 Data Outputs

### Truth Tables

Dual 1-of-4 Mode (M = A<sub>2a</sub> = H<sub>c</sub> = LOW)

Inputs				Active HIGH Outputs (H <sub>a</sub> and H <sub>b</sub> Inputs HIGH)				Active LOW Outputs (H <sub>a</sub> and H <sub>b</sub> Inputs LOW)			
$\bar{E}_{1a}$	$\bar{E}_{2a}$	A <sub>1a</sub>	A <sub>0a</sub>	Z <sub>0a</sub>	Z <sub>1a</sub>	Z <sub>2a</sub>	Z <sub>3a</sub>	Z <sub>0b</sub>	Z <sub>1b</sub>	Z <sub>2b</sub>	Z <sub>3b</sub>
H	X	X	X	L	L	L	L	H	H	H	H
X	H	X	X	L	L	L	L	H	H	H	H
L	L	L	L	H	L	L	L	L	H	H	H
L	L	L	H	L	H	L	L	H	L	H	H
L	L	H	L	L	L	H	L	H	H	L	H
L	L	H	H	L	L	L	H	H	H	H	L

Single 1-of-8 Mode (M = HIGH; A<sub>0b</sub> = A<sub>1b</sub> = H<sub>a</sub> = H<sub>b</sub> = LOW)

Inputs					Active HIGH Outputs (Note 1) (H <sub>c</sub> Input HIGH)							
$\bar{E}_1$	$\bar{E}_2$	A <sub>2a</sub>	A <sub>1a</sub>	A <sub>0a</sub>	Z <sub>0</sub>	Z <sub>1</sub>	Z <sub>2</sub>	Z <sub>3</sub>	Z <sub>4</sub>	Z <sub>5</sub>	Z <sub>6</sub>	Z <sub>7</sub>
H	X	X	X	X	L	L	L	L	L	L	L	L
X	H	X	X	X	L	L	L	L	L	L	L	L
L	L	L	L	L	H	L	L	L	L	L	L	L
L	L	L	L	H	L	H	L	L	L	L	L	L
L	L	L	H	L	L	L	H	L	L	L	L	L
L	L	L	H	H	L	L	L	H	L	L	L	L
L	L	H	L	L	L	L	L	L	H	L	L	L
L	L	H	H	L	L	L	L	L	L	H	L	L
L	L	H	L	L	L	L	L	L	L	L	H	L
L	L	H	H	L	L	L	L	L	L	L	L	H

H = HIGH Voltage Level    L = LOW Voltage Level    X = Don't Care     $\bar{E}_1 = \bar{E}_{1a}$  and  $\bar{E}_{1b}$  wired;  $\bar{E}_2 = \bar{E}_{2a}$  and  $\bar{E}_{2b}$  wired  
**Note 1:** for H<sub>c</sub> = LOW, output states are complemented

Logic Diagram

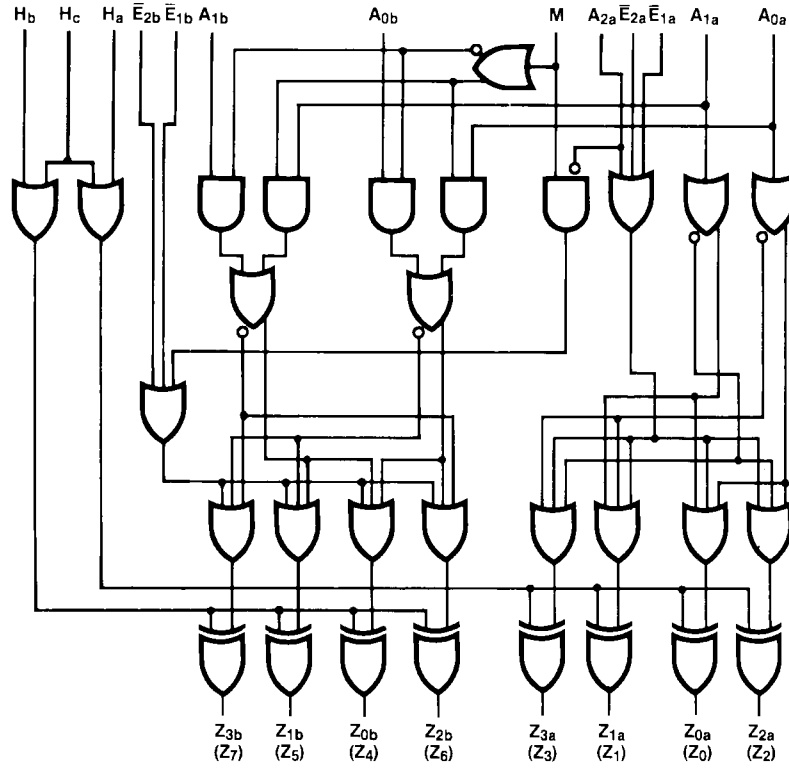

( $Z_n$ ) for 1-of-4 applications.

**Absolute Maximum Ratings** (Note 2)

Storage Temperature ( $T_{STG}$ )	-65°C to +150°C
Maximum Junction Temperature ( $T_J$ )	+150°C
$V_{EE}$ Pin Potential to Ground Pin	-7.0V to +0.5V
Input Voltage (DC)	$V_{EE}$ to +0.5V
Output Current (DC Output HIGH)	-50 mA
ESD (Note 3)	$\geq 2000V$

**Recommended Operating Conditions**

Case Temperature ( $T_C$ )	
Commercial	0°C to +85°C
Industrial	-40°C to +85°C
Supply Voltage ( $V_{EE}$ )	-5.7V to -4.2V

**Note 2:** The "Absolute Maximum Ratings" are those values beyond which the safety of the device cannot be guaranteed. The device should not be operated at these limits. The parametric values defined in the Electrical Characteristics tables are not guaranteed at the absolute maximum rating. The "Recommended Operating Conditions" table will define the conditions for actual device operation.

**Note 3:** ESD testing conforms to MIL-STD-883, Method 3015.

**Commercial Version****DC Electrical Characteristics** (Note 4)

$V_{EE} = -4.2V$  to  $-5.7V$ ,  $V_{CC} = V_{CCA} = GND$ ,  $T_C = 0^\circ C$  to  $+85^\circ C$

Symbol	Parameter	Min	Typ	Max	Units	Conditions	
$V_{OH}$	Output HIGH Voltage	-1025	-955	-870	mV	$V_{IN} = V_{IH}$ (Max) or $V_{IL}$ (Min)	Loading with 50Ω to -2.0V
$V_{OL}$	Output LOW Voltage	-1830	-1705	-1620	mV		
$V_{OHC}$	Output HIGH Voltage	-1035			mV	$V_{IN} = V_{IH}$ (Min) or $V_{IL}$ (Max)	Loading with 50Ω to -2.0V
$V_{OLC}$	Output LOW Voltage			-1610	mV		
$V_{IH}$	Input HIGH Voltage	-1165		-870	mV	Guaranteed HIGH Signal for All Inputs	
$V_{IL}$	Input LOW Voltage	-1830		-1475	mV	Guaranteed LOW Signal for All Inputs	
$I_{IL}$	Input LOW Current	0.50			μA	$V_{IN} = V_{IL}$ (Min)	
$I_{IH}$	Input HIGH Current			240	μA	$V_{IN} = V_{IH}$ (Max)	
$I_{EE}$	Power Supply Current	-95		-50	mA	Inputs OPEN	

**Note 4:** The specified limits represent the "worst case" value for the parameter. Since these values normally occur at the temperature extremes, additional noise immunity and guardbanding can be achieved by decreasing the allowable system operating ranges. Conditions for testing shown in the tables are chosen to guarantee operation under "worst case" conditions.

**AC Electrical Characteristics**

$V_{EE} = -4.2V$  to  $-5.7V$ ,  $V_{CC} = V_{CCA} = GND$

Symbol	Parameter	$T_C = 0^\circ C$		$T_C = +25^\circ C$		$T_C = +85^\circ C$		Units	Conditions
		Min	Max	Min	Max	Min	Max		
$t_{PLH}$ $t_{PHL}$	Propagation Delay $\bar{E}_{na}, \bar{E}_{nb}$ to Output	0.75	1.85	0.75	1.85	0.85	2.05	ns	Figures 1, 2
$t_{PLH}$ $t_{PHL}$	Propagation Delay $A_{na}, A_{nb}$ to Output	0.75	2.20	0.75	2.20	0.75	2.30	ns	
$t_{PLH}$ $t_{PHL}$	Propagation Delay $H_a, H_b, H_c$ to Output	0.75	2.20	0.75	2.20	0.75	2.20	ns	
$t_{PLH}$ $t_{PHL}$	Propagation Delay M to Output	1.10	2.70	1.10	2.70	1.10	3.00	ns	
$t_{TLH}$ $t_{THL}$	Transition Time 20% to 80%, 80% to 20%	0.40	1.30	0.40	1.30	0.40	1.30	ns	

## Commercial Version (Continued) PLCC AC Electrical Characteristics

 $V_{EE} = -4.2V$  to  $-5.7V$ ,  $V_{CC} = V_{CCA} = GND$ 

Symbol	Parameter	$T_C = 0^\circ C$		$T_C = +25^\circ C$		$T_C = +85^\circ C$		Units	Conditions
		Min	Max	Min	Max	Min	Max		
$t_{PLH}$ $t_{PHL}$	Propagation Delay $\bar{E}_{na}, \bar{E}_{nb}$ to Output	0.75	1.65	0.75	1.65	0.85	1.85	ns	Figures 1, 2
$t_{PLH}$ $t_{PHL}$	Propagation Delay $A_{na}, A_{nb}$ to Output	0.75	2.00	0.75	2.00	0.75	2.10	ns	
$t_{PLH}$ $t_{PHL}$	Propagation Delay $H_a, H_b, H_c$ to Output	0.75	2.00	0.75	2.00	0.75	2.00	ns	
$t_{PLH}$ $t_{PHL}$	Propagation Delay M to Output	1.10	2.50	1.10	2.50	1.10	2.80	ns	
$t_{TLH}$ $t_{THL}$	Transition Time 20% to 80%, 80% to 20%	0.40	1.20	0.40	1.20	0.40	1.20	ns	

## Industrial Version

### PLCC DC Electrical Characteristics (Note 5)

 $V_{EE} = -4.2V$  to  $-5.7V$ ,  $V_{CC} = V_{CCA} = GND$ ,  $T_C = -40^\circ C$  to  $+85^\circ C$ 

Symbol	Parameter	$T_C = -40^\circ C$		$T_C = 0^\circ C$ to $+85^\circ C$		Units	Conditions
		Min	Typ	Min	Max		
$V_{OH}$	Output HIGH Voltage	-1085	-870	-1025	-870	mV	$V_{IN} = V_{IH}$ (Max) Loading with $50\Omega$ to $-2.0V$
$V_{OL}$	Output LOW Voltage	-1830	-1575	-1830	-1620	mV	or $V_{IL}$ (Min)
$V_{OHC}$	Output HIGH Voltage	-1095		-1035		mV	$V_{IN} = V_{IH}$ (Min) Loading with $50\Omega$ to $-2.0V$
$V_{OLC}$	Output LOW Voltage		-1565		-1610	mV	or $V_{IL}$ (Max)
$V_{IH}$	Input HIGH Voltage	-1170	-870	-1165	-870	mV	Guaranteed HIGH Signal for All Inputs
$V_{IL}$	Input LOW Voltage	-1830	-1480	-1830	-1475	mV	Guaranteed LOW Signal for All Inputs
$I_{IL}$	Input LOW Current	0.50		0.50		$\mu A$	$V_{IN} = V_{IL}$ (Min)
$I_{IH}$	Input HIGH Current		300		240	$\mu A$	$V_{IN} = V_{IH}$ (Max)
$I_{EE}$	Power Supply Current	-95	-50	-95	-50	mA	Inputs OPEN

**Note 5:** The specified limits represent the "worst case" value for the parameter. Since these values normally occur at the temperature extremes, additional noise immunity and guardbanding can be achieved by decreasing the allowable system operating ranges. Conditions for testing shown in the tables are chosen to guarantee operation under "worst case" conditions.

### PLCC AC Electrical Characteristics

 $V_{EE} = -4.2V$  to  $-5.7V$ ,  $V_{CC} = V_{CCA} = GND$ 

Symbol	Parameter	$T_C = -40^\circ C$		$T_C = +25^\circ C$		$T_C = +85^\circ C$		Units	Conditions
		Min	Max	Min	Max	Min	Max		
$t_{PLH}$ $t_{PHL}$	Propagation Delay $\bar{E}_{na}, \bar{E}_{nb}$ to Output	0.75	1.65	0.75	1.65	0.85	1.85	ns	Figures 1 Figure 2
$t_{PLH}$ $t_{PHL}$	Propagation Delay $A_{na}, A_{nb}$ to Output	0.65	2.00	0.75	2.00	0.75	2.10	ns	
$t_{PLH}$ $t_{PHL}$	Propagation Delay $H_a, H_b, H_c$ to Output	0.70	2.00	0.75	2.00	0.75	2.00	ns	
$t_{PLH}$ $t_{PHL}$	Propagation Delay M to Output	1.10	2.50	1.10	2.50	1.10	2.80	ns	
$t_{TLH}$ $t_{THL}$	Transition Time 20% to 80%, 80% to 20%	0.40	1.30	0.40	1.20	0.40	1.20	ns	

### Test Circuit

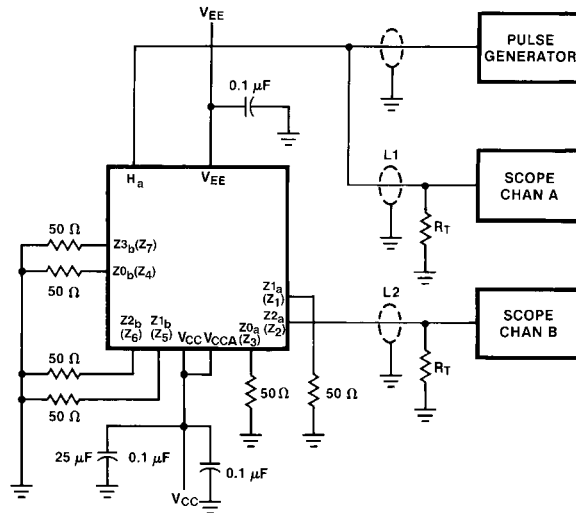

**Notes:**

- V<sub>CC</sub>, V<sub>CCA</sub> = +2V, V<sub>EE</sub> = -2.5V
- L1 and L2 = equal length 50Ω impedance lines
- R<sub>T</sub> = 50Ω terminator internal to scope
- Decoupling 0.1 μF from GND to V<sub>CC</sub> and V<sub>EE</sub>
- All unused outputs are loaded with 50Ω to GND
- C<sub>L</sub> = Fixture and stray capacitance ≤ 3 pF

FIGURE 1. AC Test Circuit

### Switching Waveforms

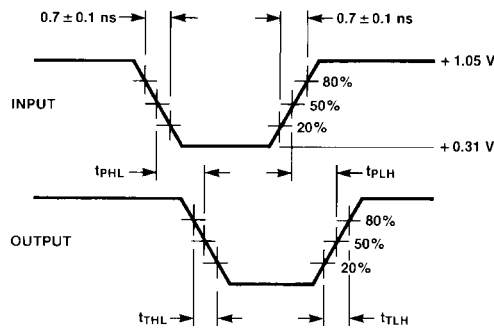
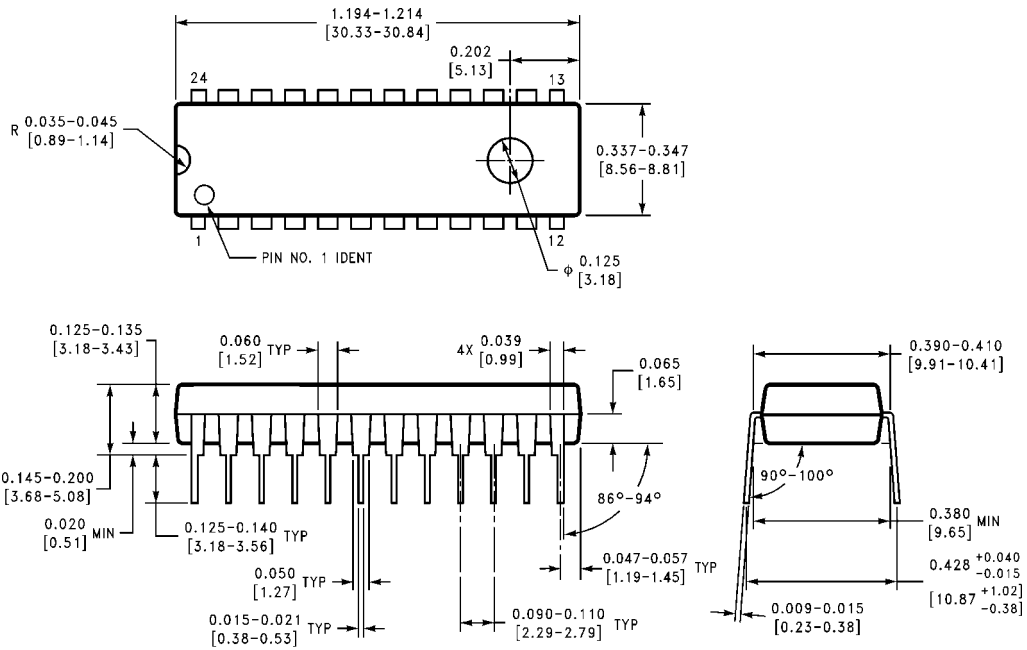

FIGURE 2. Propagation Delay and Transition Times

**Physical Dimensions** inches (millimeters) unless otherwise noted



N24E (REV A)

**24-Lead Plastic Dual-In-Line Package (PDIP), JEDEC MS-011, 0.400 Wide  
Package Number N24E**

**Physical Dimensions** inches (millimeters) unless otherwise noted (Continued)

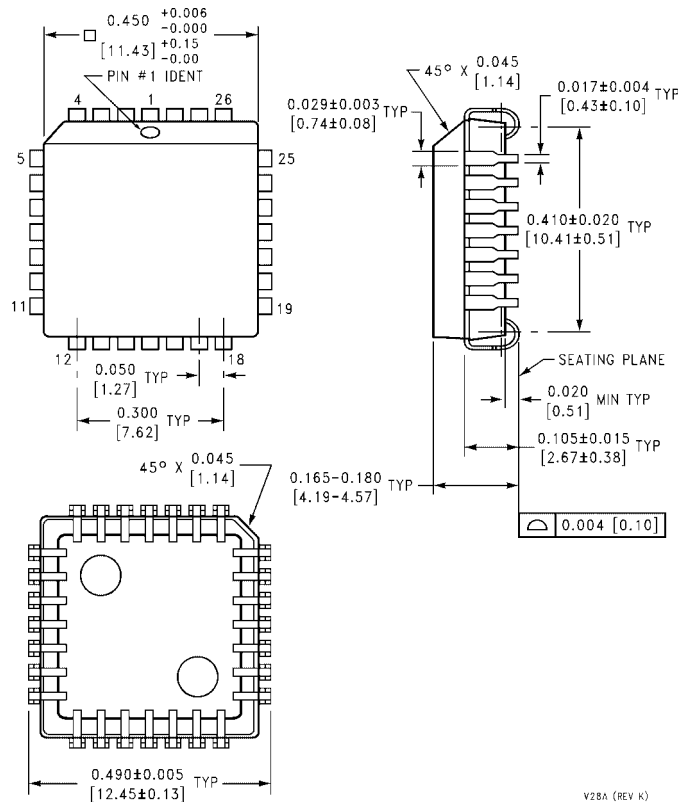

**28-Lead Plastic Lead Chip Carrier (PLCC), JEDEC MO-047, 0.450 Square Package Number V28A**

V28A (REV K)

Fairchild does not assume any responsibility for use of any circuitry described, no circuit patent licenses are implied and Fairchild reserves the right at any time without notice to change said circuitry and specifications.

**LIFE SUPPORT POLICY**

FAIRCHILD'S PRODUCTS ARE NOT AUTHORIZED FOR USE AS CRITICAL COMPONENTS IN LIFE SUPPORT DEVICES OR SYSTEMS WITHOUT THE EXPRESS WRITTEN APPROVAL OF THE PRESIDENT OF FAIRCHILD SEMICONDUCTOR CORPORATION. As used herein:

1. Life support devices or systems are devices or systems which, (a) are intended for surgical implant into the body, or (b) support or sustain life, and (c) whose failure to perform when properly used in accordance with instructions for use provided in the labeling, can be reasonably expected to result in a significant injury to the user.
2. A critical component in any component of a life support device or system whose failure to perform can be reasonably expected to cause the failure of the life support device or system, or to affect its safety or effectiveness.

[www.fairchildsemi.com](http://www.fairchildsemi.com)