

100390

Low Power Single Supply Hex PECL-to-TTL Translator

General Description

The 100390 is a hex translator for converting F100K logic levels to TTL logic levels. Unlike other level translators, the 100390 operates using only one +5V supply. Differential inputs allow each circuit to be used as an inverting, non inverting, or differential receiver. An internal reference generator provides V_{BB} for single-ended operation. The standard FAST® 3-STATE outputs are enabled by a common active low TTL compatible \overline{OE} input. Partitioned V_{CC} s on chip are brought out on separate power pins, allowing the noisy TTL V_{CC} power plane to be isolated from the relatively quiet ECL V_{CC} . The 100390 is ideal for applications limited to a single +5V supply, allowing for easy ECL to TTL Interfacing.

Features

- Operates from a single +5V supply
- 3-STATE outputs
- 2000V ESD protection
- V_{BB} supplied for single-ended operation

Order Code:

Order Number	Package Number	Package Description
100390SC	M24B	24-Lead Small Outline Integrated Circuit (SOIC), JEDEC MS-013, 0.300 Wide
100390PC	N24E	24-Lead Plastic Dual-In-Line Package (PDIP), JEDEC MS-011, 0.400 Wide
100390QC	V28A	28-Lead Plastic Lead Chip Carrier (PLCC), JEDEC MO-047, 0.450 Square
100390QI	V28A	28-Lead Plastic Lead Chip Carrier (PLCC), JEDEC MO-047, 0.450 Square Industrial Temperature Range (-40°C to +85°C)

Devices also available in Tape and Reel. Specify by appending the suffix letter "X" to the ordering code.

Logic Symbol

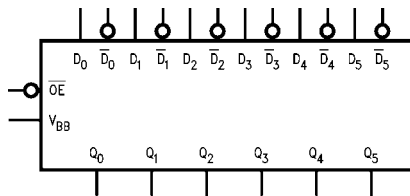

Connection Diagrams

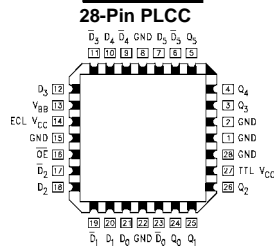
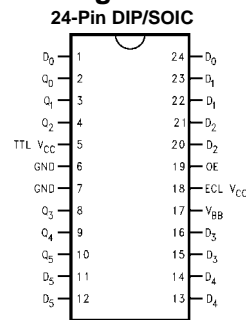

Pin Descriptions

Pin Names	Description
D_0 – D_5	Data Inputs (PECL)
\overline{D}_0 – \overline{D}_5	Inverting Data Inputs (PECL)
Q_0 – Q_5	Data Outputs (TTL)
\overline{OE}	Output Enable (TTL)
V_{BB}	Reference Voltage (PECL)

FAST® is a registered trademark of Fairchild Semiconductor.

Truth Table

Data Inputs (PECL)		Control Input (TTL)	TTL Outputs	Comments
D_n	\bar{D}_n	\overline{OE}	Q_n	
X	X	H	Z	Outputs Disable
L	H	L	L	Differential Operation
H	L	L	H	Differential Operation
L	L	L	U	Invalid Input States
H	H	L	U	Invalid Input States
OPEN	OPEN	L	U	Invalid Input States
L	V_{BB}	L	L	Single Ended Operation
H	V_{BB}	L	H	Single Ended Operation
V_{BB}	L	L	H	Single Ended Operation
V_{BB}	H	L	L	Single Ended Operation
V_{BB}	OPEN	L	H	Single Ended Operation
OPEN	V_{BB}	L	L	Single Ended Operation

H = HIGH Voltage Level
 L = LOW Voltage Level
 Z = HIGH Impedance
 U = Undefined

Logic Diagram

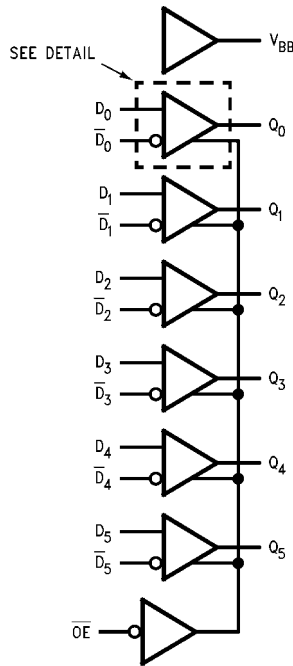

Detail

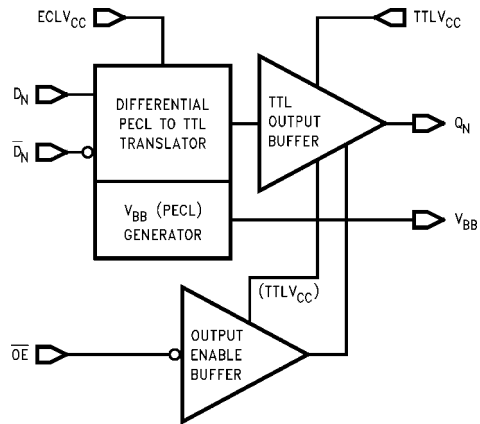

Absolute Maximum Ratings(Note 1)

Storage Temperature	-65°C to +150°C
Maximum Junction Temperature	+150°C
V _{CC} Pin Potential to Ground Pin	-0.5V to +7.0V
TTL Input Voltage (Note 2)	-0.5V to +7.0V
TTL Input Current (Note 2)	-30 mA to +5.0 mA
V _{BB} Output Current	-5.0 mA to +1.0 mA
ECL Input Potential	GND to ECL V _{CC} + 0.5V
V _{CC} Differential	
ECL V _{CC} to TTL V _{CC}	-1.0V to +1.0V
Voltage Applied to Output	
in HIGH State (with V _{CC} = 0V)	
3-STATE Output	-0.5V to +5.5V
Current Applied to Output	
in LOW State (Max)	Twice the Rated I _{OL} (mA)
ESD Last Passing Voltage (Min)	2000V

Recommended Operating Conditions

Case Temperature	0°C to +85°C
Supply Voltage	+4.75V to +5.25V

Note 1: The "Absolute Maximum Ratings" are those values beyond which the safety of the device cannot be guaranteed. The device should not be operated at these limits. The parametric values defined in the Electrical Characteristics tables are not guaranteed at the absolute maximum rating. The "Recommended Operating Conditions" table will define the conditions for actual device operation.

Note 2: Either voltage limit or current limit is sufficient to protect inputs.

DC Electrical Characteristics

ECL V_{CC} = +5.0V ±5%, TTL V_{CC} = +5.0V ±5%, GND = 0V

Symbol	Parameter	Min	Max	Units	Conditions	
V _{IH}	Input HIGH Voltage	Data	ECL V _{CC} - 1.165	ECL V _{CC} - 0.870	V	Guaranteed HIGH Signal for ALL Inputs (with One Input Tied to V _{BB})
		\overline{OE}	2.0		V	Guaranteed HIGH Signal (TTL)
V _{IL}	Input LOW Voltage	Data	ECL V _{CC} - 1.830	ECL V _{CC} - 1.475	V	Guaranteed LOW Signal for ALL Inputs (with One Input Tied to V _{BB})
		\overline{OE}		0.8	V	Guaranteed LOW Signal (TTL)
V _{BB}	Output Reference Voltage	ECL V _{CC} - 1.38	ECL V _{CC} - 1.26	V	I _{BB} = 0.0 mA or -1.0 mA	
V _{OH}	Output HIGH Voltage (TTL)	2.7		V	I _{OH} = -3 mA	
V _{OL}	Output LOW Voltage (TTL)		0.5	V	I _{OL} = 24 mA	
I _{IH}	Input HIGH Current	Data		50	μA	V _{IN} = V _{IH} (Max), D ₀ -D ₅ = V _{BB} , D ₀ -D ₅ = V _{IL} (Min)
		\overline{OE}		20	μA	V _{IN} = 2.7V (TTL)
I _{IL}	Input LOW Current		-200	μA	V _{IN} = 0.5V (TTL)	
I _{BVI}	Input Breakdown Current		10	μA	V _{IN} = 7.0V (TTL)	
I _{CBO}	Input Leakage Current	-10		μA	V _{IN} = GND, D ₀ -D ₅ = V _{BB} , D ₀ -D ₅ = V _{IL} (Min)	
I _{OZH}	3-STATE Current Output HIGH		50	μA	V _{OUT} = +2.7V	
I _{OZL}	3-STATE Current Output LOW		-50	μA	V _{OUT} = +0.5V	
I _{CC}	ECL Supply Current	13	30	mA		
I _{CCZ}	TTL Supply Current	10	20	mA	3-STATE	
I _{CCL}	TTL Supply Current	8	17	mA	LOW State	
I _{CCH}	TTL Supply Current HIGH	0.4	2.0	mA	HIGH State	
I _{OS}	Output Short-Circuit Current	-150	-60	mA	V _{OUT} = 0.0V, V _{CC} = +5.25	
V _{Dif}	Differential Input Voltage	150		mV	Required for Full Output Swing	
V _{CM}	Common Mode Voltage	ECL V _{CC} - 2.0	ECL V _{CC} - 0.5	V		
V _{CD}	Clamp Diode Voltage		-1.2	V	I _{IN} = -18 mA	

DIP AC Electrical Characteristics $V_{CC} = 5.0V \pm 5\%$; $T_C = 0^\circ C$ to $+85^\circ C$

Symbol	Parameter	$T_C = 0^\circ C$		$T_C = +25^\circ C$		$T_C = +85^\circ C$		Units	Figure Number
		Min	Max	Min	Max	Min	Max		
f_{MAX}	Maximum Clock Frequency	100		100		100		MHz	
t_{PLH} t_{PHL}	Propagation Delay Data to Output	3.5	7.2	3.5	6.8	3.5	6.7	ns	Figure 1
t_{PZH} t_{PZL}	Output Enable Time	2.7	4.8	2.7	4.8	3.0	5.1	ns	Figure 2
t_{PHZ} t_{PLZ}	Output Disable Time	2.9	5.8	2.9	5.4	2.7	5.1	ns	Figure 2
		2.3	3.9	2.2	3.9	2.2	3.9		

SOIC and PLCC Package AC Electrical Characteristics $V_{CC} = 5.0V \pm 5\%$; $T_C = 0^\circ C$ to $+85^\circ C$

Symbol	Parameter	$T_C = 0^\circ C$		$T_C = +25^\circ C$		$T_C = +85^\circ C$		Units	Figure Number
		Min	Max	Min	Max	Min	Max		
f_{MAX}	Maximum Clock Frequency	100		100		100		MHz	
t_{PLH} t_{PHL}	Propagation Delay Data to Output	3.5	7.0	3.5	6.6	3.5	6.5	ns	Figure 1
t_{PZH} t_{PZL}	Output Enable Time	2.7	4.6	2.7	4.6	3.0	4.9	ns	Figure 2
t_{PHZ} t_{PLZ}	Output Disable Time	2.9	5.6	2.9	5.2	2.7	4.9	ns	Figure 2
		2.3	3.7	2.2	3.7	2.2	3.7		

Switching Waveforms

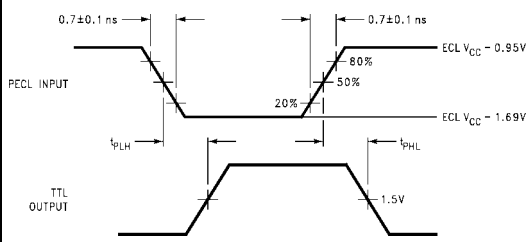

FIGURE 1. Data to Output Propagation Delay

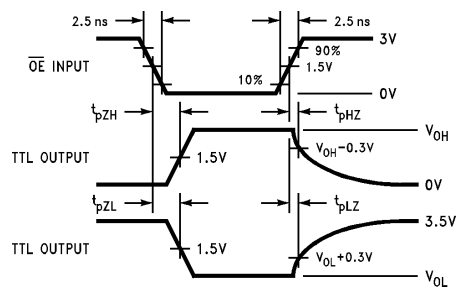
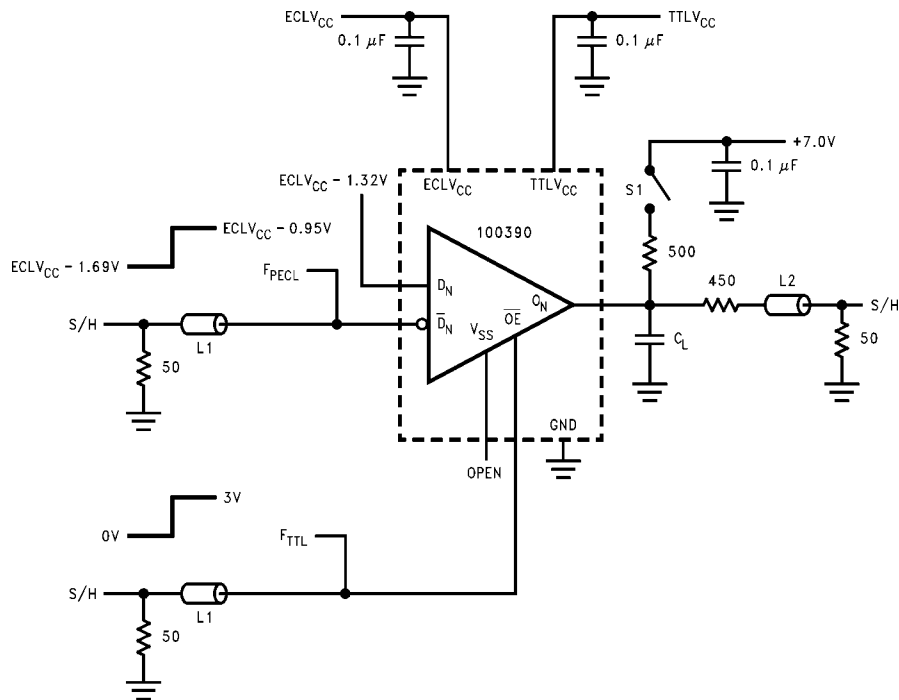

FIGURE 2. Enable/Disable Propagation Delay

Test Circuit



Notes:

- GND = 0V, ECL V_{CC} = +5V, TTL V_{CC} = +5V
- L1 and L2 = equal length 50Ω impedance lines
- 50Ω terminators are internal to S/H measurement unit
- Decoupling 0.1 μF from GND to ECL V_{CC} and TTL V_{CC}
- All unused outputs are loaded with 500Ω to GND
- C_L = Fixture and stray capacitance = 50 pF
- Switch S1 is open for t_{PLH}, t_{PHL}, t_{PHZ} and t_{PZH} tests
- Switch S1 is closed only for t_{PLZ} and t_{PZL} tests

FIGURE 3. AC Test Circuit

Application Notes

1. Device performance will be enhanced by the use of dual V_{CC} power planes as illustrated in the Application Figures 4, 5. This will minimize the coupling of TTL switching noise into the primary reference to the ECL circuitry and take full advantage of the 100390's on chip V_{CC} partitioning.
2. The device's partitioned V_{CC} may be operated from two 5V, 5% tolerance, supplies provided that they are ramped up/down together so that the max differential is 1V. This is to prevent overstress to internal ESD diodes. If the ECL driver to the F390 is powered from a separate supply, it must obey this sequence rule also.
3. Glitch-free power up, independent of Data input levels, is achieved if TTL logic HIGH is held on the Output Enable pin during ramping up/down of the V_{CC} supply.
4. Undefined output states can occur for some invalid combinations. See Truth Table. This should be avoided to prevent possible oscillation or increased power consumption due to TTL outputs biased into a quasi state with both pull-up and pull-down stages partially on. 3-STATEing the outputs will counteract the effects of invalid input states.
5. Pins 8, 15, and 22 on the 28-pin PLCC package are tied to the chip's substrate and are named GNDs. These pins are electrically common to the ground pins 1, 2, and 28. For best thermal performance, tie the GND pins to the circuit ground plane. They may be tied to an electrically isolated thermal dissipation plane or may float.
6. Figure 4 illustrates typical differential input operation.
7. Figure 5 illustrates typical single-ended input operation.

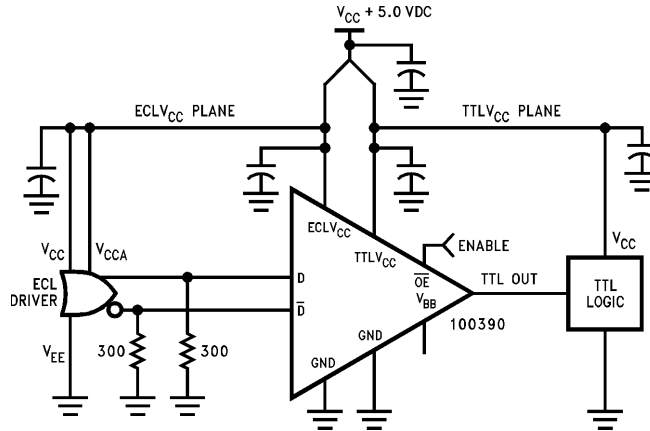

FIGURE 4.

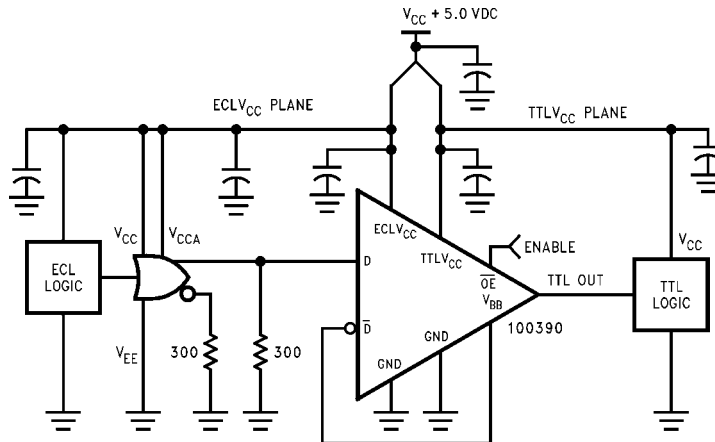
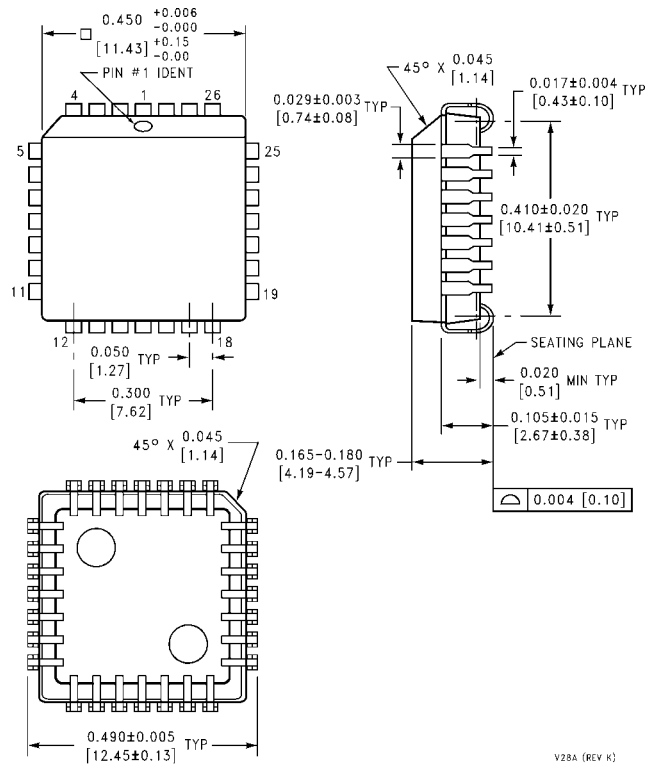

FIGURE 5.

Physical Dimensions inches (millimeters) unless otherwise noted (Continued)



28-Lead Plastic Lead Chip Carrier (PLCC), JEDEC MO-047, 0.450 Square Package Number V28A

V28A (REV K)

Fairchild does not assume any responsibility for use of any circuitry described, no circuit patent licenses are implied and Fairchild reserves the right at any time without notice to change said circuitry and specifications.

LIFE SUPPORT POLICY

FAIRCHILD'S PRODUCTS ARE NOT AUTHORIZED FOR USE AS CRITICAL COMPONENTS IN LIFE SUPPORT DEVICES OR SYSTEMS WITHOUT THE EXPRESS WRITTEN APPROVAL OF THE PRESIDENT OF FAIRCHILD SEMICONDUCTOR CORPORATION. As used herein:

1. Life support devices or systems are devices or systems which, (a) are intended for surgical implant into the body, or (b) support or sustain life, and (c) whose failure to perform when properly used in accordance with instructions for use provided in the labeling, can be reasonably expected to result in a significant injury to the user.
2. A critical component in any component of a life support device or system whose failure to perform can be reasonably expected to cause the failure of the life support device or system, or to affect its safety or effectiveness.

www.fairchildsemi.com