

9403A First-In First-Out (FIFO) Buffer Memory

General Description

The 9403A is an expandable fall-through type high-speed First-In First-Out (FIFO) Buffer Memory optimized for high speed disk or tape controllers and communication buffer applications. It is organized as 16-words by 4-bits and may be expanded to any number of words or any number of bits in multiples of four. Data may be entered or extracted asynchronously in serial or parallel, allowing economical implementation of buffer memories.

The 9403A has 3-STATE outputs which provide added versatility and is fully compatible with all TTL families.

Features

- Serial or parallel input
- Serial or parallel output
- Expandable without external logic
- 3-STATE outputs
- Fully compatible with all TTL families
- Slim 24-pin package

Ordering Code:

Order Number	Package Number	Package Description
9403APC	N24E	24-Lead Plastic Dual-In-Line Package (PDIP), JEDEC MS-011, 0.400 Wide

Devices also available in Tape and Reel. Specify by appending the suffix letter "X" to the ordering code.

Logic Symbol

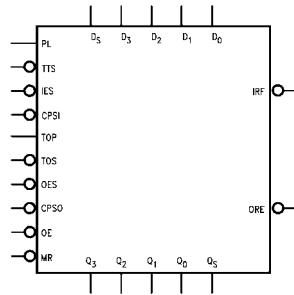

Connection Diagram

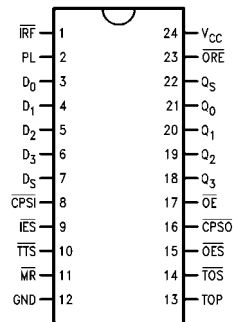

Unit Loading/Fan Out

Pin Names	Description	U.L. HIGH/LOW	Input I_{IH}/I_{IL} Output I_{OH}/I_{OL}
D_0-D_8	Parallel Data Inputs	2.0/0.667	40 μ A/400 μ A
D_S	Serial Data Input	2.0/0.667	40 μ A/400 μ A
P_L	Parallel Load Input	2.0/0.667	40 μ A/400 μ A
\overline{CPSI}	Serial Input Clock	2.0/0.667	40 μ A/400 μ A
\overline{IES}	Serial Input Enable	2.0/0.667	40 μ A/400 μ A
\overline{TTS}	Transfer to Stack Input	2.0/0.667	40 μ A/400 μ A
\overline{OES}	Serial Output Enable	2.0/0.667	40 μ A/400 μ A
\overline{TOS}	Transfer Out Serial	2.0/0.667	40 μ A/400 μ A
TOP	Transfer Out Parallel	2.0/0.667	40 μ A/400 μ A
\overline{MR}	Master Reset	2.0/0.667	40 μ A/400 μ A
\overline{OE}	Output Enable	2.0/0.667	40 μ A/400 μ A
\overline{CPSO}	Serial Output Clock	2.0/0.667	40 μ A/400 μ A
$Q_0 - Q_3$	Parallel Data Outputs	285/26.7	5.7 mA/16 mA
Q_S	Serial Data Output	285/26.7	5.7 mA/16 mA
\overline{IRF}	Input Register Full	20/13.3	-400 μ A/8 mA
\overline{ORE}	Output Register Empty	20/13.3	-400 μ A/8 mA

Block Diagram

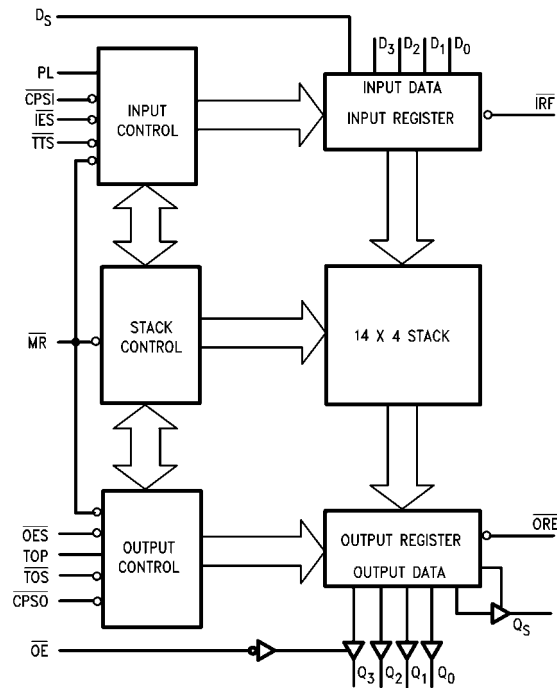

Functional Description

As shown in the block diagram the 9403A consists of three sections:

1. An Input Register with parallel and serial data inputs as well as control inputs and outputs for input handshaking and expansion.
2. A 4-bit wide, 14-word deep fall-through stack with self-contained control logic.
3. An Output Register with parallel and serial data outputs as well as control inputs and outputs for output handshaking and expansion.

Since these three sections operate asynchronously and almost independently, they will be described separately below.

INPUT REGISTER (DATA ENTRY)

The Input Register can receive data in either bit-serial or in 4-bit parallel form. It stores this data until it is sent to the fall-through stack and generates the necessary status and control signals.

Figure 1 is a conceptual logic diagram of the input section. As described later, this 5-bit register is initialized by setting

the F_3 flip-flop and resetting the other flip-flops. The \bar{Q} output of the last flip-flop (FC) is brought out as the "Input Register Full" output (\overline{IRF}). After initialization this output is HIGH.

Parallel Entry—A HIGH on the PL input loads the D_0 - D_3 inputs into the F_0 - F_3 flip-flops and sets the FC flip-flop. This forces the \overline{IRF} output LOW indicating that the input register is full. During parallel entry, the \overline{CPSI} input must be LOW. If parallel expansion is not being implemented, \overline{IES} must be LOW to establish row mastership (see Expansion section).

Serial Entry—Data on the D_S input is serially entered into the F_3, F_2, F_1, F_0, FC shift register on each HIGH-to-LOW transition of the \overline{CPSI} clock input, provided \overline{IES} and PL are LOW.

After the fourth clock transition, the four data bits are located in the four flip-flops, F_0 - F_3 . The FC flip-flop is set, forcing the \overline{IRF} output LOW and internally inhibiting \overline{CPSI} clock pulses from affecting the register, Figure 2 illustrates the final positions in a 9403A resulting from a 64-bit serial bit train. B_0 is the first bit, B_{63} the last bit.

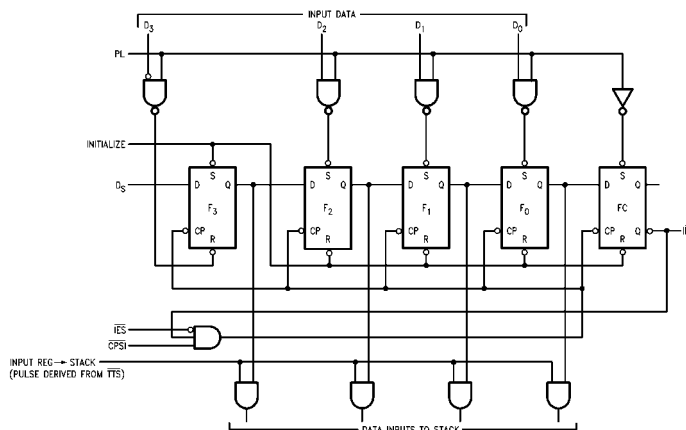

FIGURE 1. Conceptual Input Section

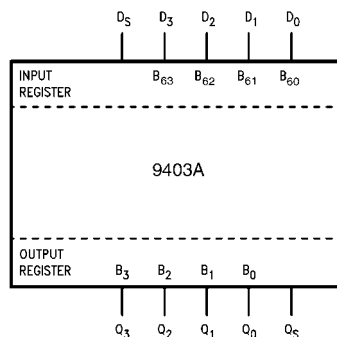

FIGURE 2. Final Positions in a 9403A Resulting from a 64-Bit Serial Train

Transfer to the Stack—The outputs of Flip-Flops F_0 - F_3 feed the stack. A LOW level on the \overline{TTS} input initiates a “fall-through” action. If the top location of the stack is empty, data is loaded into the stack and the input register is re-initialized. Note that this initialization is postponed until \overline{PL} is LOW again. Thus, automatic FIFO action is achieved by connecting the \overline{IRF} output to the \overline{TTS} input.

An RS Flip-Flop (the Request Initialization Flip-Flop shown in Figure 10) in the control section records the fact that data has been transferred to the stack. This prevents multiple entry of the same word into the stack despite the fact the \overline{IRF} and \overline{TTS} may still be LOW. The Request Initialization Flip-Flop is not cleared until \overline{PL} goes LOW. Once in the

stack, data falls through the stack automatically, pausing only when it is necessary to wait for an empty next location. In the 9403A as in most modern FIFO designs, the \overline{MR} input only initializes the stack control section and does not clear the data.

OUTPUT REGISTER (DATA EXTRACTION)

The Output Register receives 4-bit data words from the bottom stack location, stores it and outputs data on a 3-STATE 4-bit parallel data bus or on a 3-STATE serial data bus. The output section generates and receives the necessary status and control signals. Figure 3 is a conceptual logic diagram of the output section.

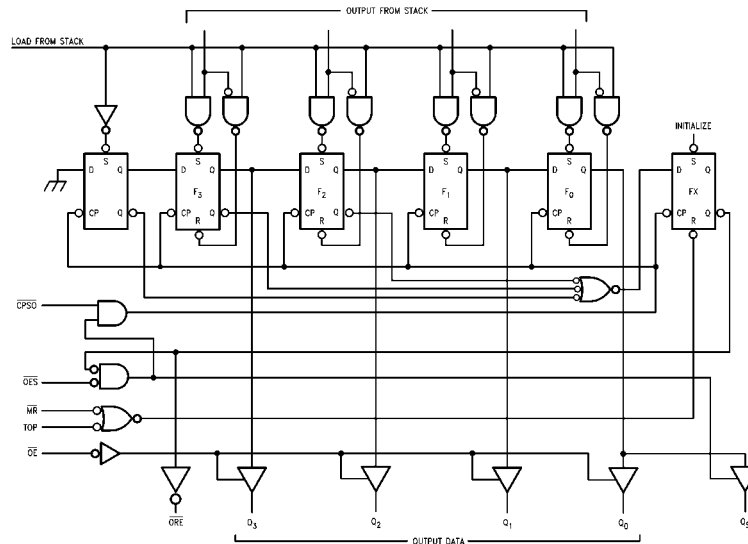

FIGURE 3. Conceptual Output Section

Parallel Data Extraction—When the FIFO is empty after a LOW pulse is applied to \overline{MR} , the Output Register Empty (\overline{ORE}) output is LOW. After data has been entered into the FIFO and has fallen through to the bottom stack location, it is transferred into the Output Register provided the “Transfer Out Parallel” (\overline{TOP}) input is HIGH. As a result of the data transfer \overline{ORE} goes HIGH, indicating valid data on the data outputs (provided the 3-STATE buffer is enabled). \overline{TOP} can now be used to clock out the next word. When \overline{TOP} goes LOW, \overline{ORE} will go LOW indicating that the output data has been extracted, but the data itself remains on the output bus until the next HIGH level at \overline{TOP} permits the transfer of the next word (if available) into the Output Register. During parallel data extraction \overline{CPSO} should be LOW. \overline{TOS} should be grounded for single slice operation or connected to the appropriate \overline{ORE} for expanded operation (see Expansion section).

\overline{TOP} is not edge triggered. Therefore, if \overline{TOP} goes HIGH before data is available from the stack, but data does become available before \overline{TOP} goes LOW again, that data will be transferred into the Output Register. However, internal control circuitry prevents the same data from being

transferred twice. If \overline{TOP} goes HIGH and returns to LOW before data is available from the stack, \overline{ORE} remains LOW indicating that there is no valid data at the outputs.

Serial Data Extraction—When the FIFO is empty after a LOW pulse is applied to \overline{MR} , the Output Register Empty (\overline{ORE}) output is LOW. After data has been entered into the FIFO and has fallen through to the bottom stack location, it is transferred into the Output Register provided \overline{TOS} is LOW and \overline{TOP} is HIGH. As a result of the data transfer \overline{ORE} goes HIGH indicating valid data in the register. The 3-STATE Serial Data Output, Q_S , is automatically enabled and puts the first data bit on the output bus. Data is serially shifted out on the HIGH-to-LOW transition of \overline{CPSO} . To prevent false shifting, \overline{CPSO} should be LOW when the new word is being loaded into the Output Register. The fourth transition empties the shift register, forces \overline{ORE} output LOW and disables the serial output, Q_S (refer to Figure 3). For serial operation the \overline{ORE} output may be tied to the \overline{TOS} input, requesting a new word from the stack as soon as the previous one has been shifted out.

EXPANSION

Vertical Expansion—The 9403A may be vertically expanded to store more words without external parts. The interconnection is necessary to form a 46-word by 4-bit FIFO are shown in Figure 4. Using the same technique, and FIFO of $(15n + 1)$ -words by 4-bits can be constructed, where n is the number of devices. Note that expansion does not sacrifice any of the 9403A's flexibility for serial/parallel input and output.

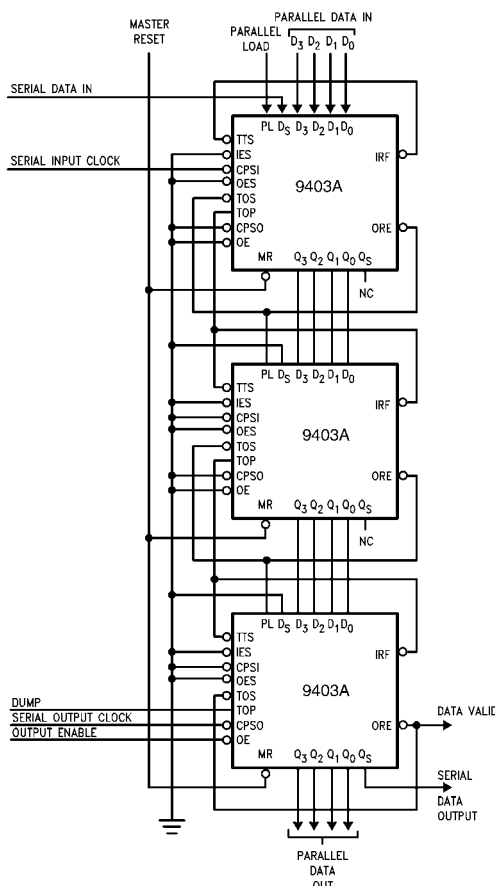

FIGURE 4. A Vertical Expansion Scheme

Horizontal Expansion—The 9403A can also be horizontally expanded to store long words (in multiples of four bits) without external logic. The interconnections necessary to form a 16-word by 12-bit FIFO are shown in Figure 5. Using the same technique, any FIFO of 16 words by $4n$ bits can be constructed, where n is the number of devices. The IRF output of the right most device (most significant device) is connected to the TTS inputs of all devices. Similarly, the ORE output of the most significant device is connected to the TOS inputs of all devices. As in the vertical expansion scheme, horizontal expansion does not sacrifice any of the 9403A's flexibility for serial/parallel input and output.

Horizontal and Vertical Expansion—The 9403A can be expanded in both the horizontal and vertical directions without any external parts and without sacrificing any of its FIFO's flexibility for serial/parallel input and output. The interconnections necessary to form a 31-word by 16-bit FIFO are shown in Figure 6. Using the same technique, any FIFO of $(15m + 1)$ -words by $(4n)$ -bits can be constructed, where m is the number of devices in a column and n is the number of devices in a row. Figure 7 and Figure 8 show the timing diagrams for serial data entry and extraction for the 31-word by 16-bit FIFO shown in Figure 6. The final position of data after serial insertion of 496 bits into the FIFO array of Figure 6 is shown in Figure 9.

Interlocking Circuitry—Most conventional FIFO designs provide status signals analogous to IRF and ORE. However, when these devices are operated in arrays, variations in unit to unit operating speed require external gating to assure all devices have completed an operation. The 9403A incorporates simple but effective "master/slave" interlocking circuitry to eliminate the need for external gating.

In the 9403A array of Figure 6 devices 1 and 5 are defined as "row masters" and the other devices are slaves to the master in their row. No slave in a given row will initialize its Input Register until it has received LOW on its IES input from a row master or a slave of higher priority.

In a similar fashion, the ORE outputs of slaves will not go HIGH until their OES inputs have gone HIGH. This interlocking scheme ensures that new input data may be accepted by the array when the IRF output of the final slave in that row goes HIGH and that output data for the array may be extracted when the ORE of the final slave in the output row goes HIGH.

The row master is established by connecting its IES input to ground while a slave receives its IES input from the IRF output of the next higher priority device. When an array of 9403A FIFOs is initialized with a LOW on the MR inputs of all devices, the IRF outputs of all devices will be HIGH. Thus, only the row master receives a LOW on the IES input during initialization. Figure 10 is a conceptual logic diagram of the internal circuitry which determines master/slave operation. Whenever MR and IES are LOW, the Master Latch is set. Whenever TTS goes LOW the Request Initialization Flip-Flop will be set. If the Master Latch is HIGH, the input Register will be immediately initialized and the Request Initialization Flip-Flop reset. If the Master Latch is reset, the Input Register is not initialized until IES goes LOW. In array operation, activating the TTS initiates a ripple input register initialization from the row master to the last slave.

A similar operation takes place for the output register. Either a TOS or TOP input initiates a load-from-stack operation and sets the ORE Request Flip-Flop. If the Master Latch is set, the last Output Register Flip-Flop is set and ORE goes HIGH. If the Master latch is reset, the ORE output will be LOW until an OES input is received.

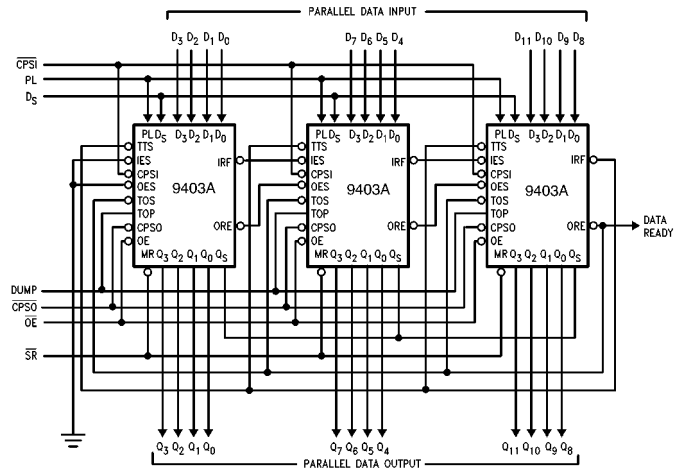

FIGURE 5. A Horizontal Expansion Scheme

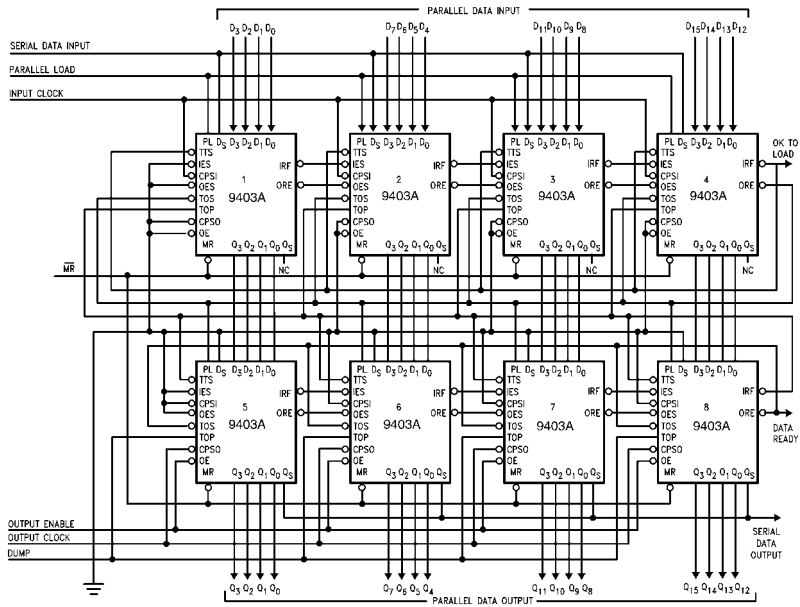

FIGURE 6. A 31x16 FIFO Array

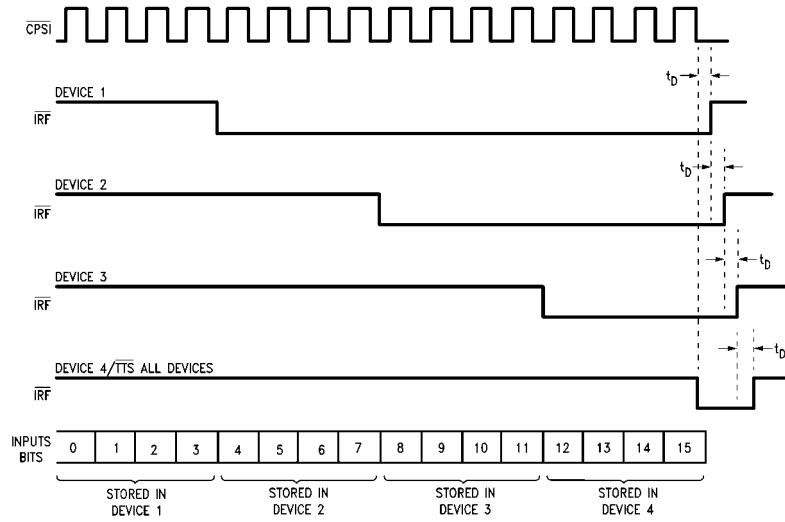

FIGURE 7. Serial Data Entry for Array of Figure 6

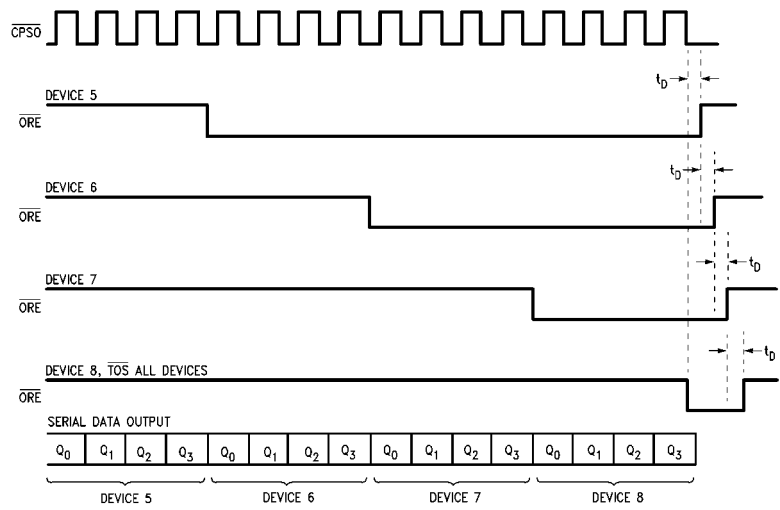

FIGURE 8. Serial Data Extraction for Array of Figure 6

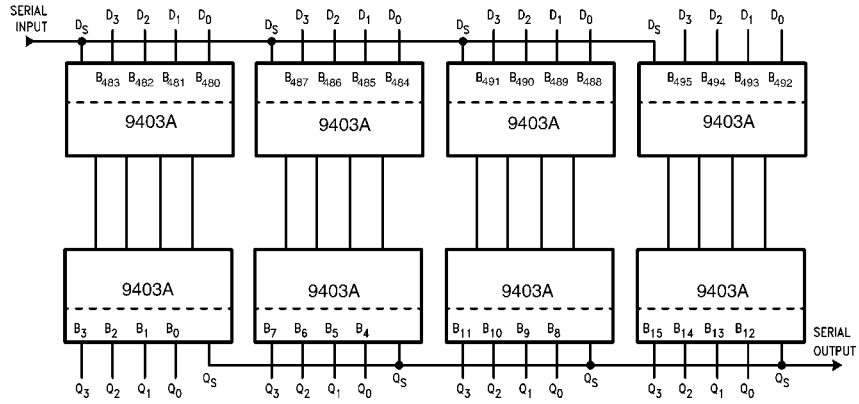

FIGURE 9. Final Position of a 496-Bit Serial Input

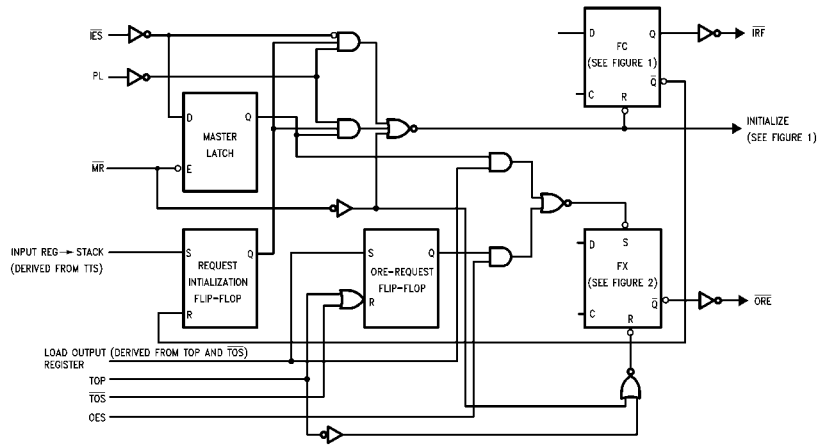

FIGURE 10. Conceptual Diagram, Interlocking Circuitry

Absolute Maximum Ratings(Note 1)

Storage Temperature	-65°C to +150°C
Ambient Temperature under Bias	-55°C to +125°C
Junction Temperature under Bias	-55°C to +175°C
V _{CC} Pin Potential to Ground Pin	-0.5V to +7.0V
Input Voltage (Note 2)	-0.5V to +7.0V
Input Current (Note 2)	-30 mA to +5.0 mA
Voltage Applied to Output in HIGH State (with V _{CC} = 0V)	
Standard Output	-0.5V to V _{CC}
3-STATE Output	-0.5V to +5.5V
Current Applied to Output in LOW State (Max)	twice the rated I _{OL} (mA)

Recommended Operating Conditions

Free Air Ambient Temperature	0°C to +70°C
Supply Voltage	+4.5V to +5.5V

Note 1: Absolute maximum ratings are values beyond which the device may be damaged or have its useful life impaired. Functional operation under these conditions is not implied.

Note 2: Either voltage limit or current limit is sufficient to protect inputs.

DC Electrical Characteristics

Symbol	Parameter	Min	Typ	Max	Units	V _{CC}	Conditions
V _{IH}	Input HIGH Voltage	2.0			V		Recognized as a HIGH Signal
V _{IL}	Input LOW Voltage			0.8	V		Recognized as a LOW Signal
V _{CD}	Input Clamp Diode Voltage			-1.5	V	Min	I _{IN} = -18 mA
V _{OH}	Output HIGH Voltage	10% V _{CC}	2.4		V	Min	I _{OH} = -400 μA (IRF, ORE) I _{OH} = -5.7 mA (Q _n , Q _s)
V _{OL}	Output LOW Voltage	10% V _{CC}		0.5	V	Min	I _{OL} = 8 mA (IRF, ORE) I _{OL} = 16 Ma (Q _n , Q _s)
I _{IH}	Input HIGH Current			40	μA	Max	V _{IN} = 2.7V
I _{BVI}	Input HIGH Current Breakdown Test			100	μA	Max	V _{IN} = 7.0V
I _{IL}	Input LOW Current			-0.45	mA	Max	V _{IN} = 0.4V
I _{OZH}	Output Leakage Current			100	μA	Max	V _{OUT} = 2.4V
I _{OZL}	Output Leakage Current			-100	μA	Max	V _{OUT} = 0.5V
I _{OS}	Output Short-Circuit Current	-30		-130	mA	Max	V _{OUT} = 0V
I _{CEX}	Output HIGH Leakage Current			250	μA	Max	V _{OUT} = V _{CC}
I _{CC}	Power Supply Current			170	mA	Max	V _O = LOW

AC Electrical Characteristics							
Symbol	Parameter	$T_A = +25^\circ\text{C}$ $V_{CC} = +5.0\text{V}$ $C_L = 50\text{ pF}$		$T_A = 0^\circ\text{C to } 70^\circ\text{C}$ $V_{CC} = +5.0\text{V}$ $C_L = 50\text{ pF}$		Units	Figure Number
		Min	Max	Min	Max		
t_{PHL}	Propagation Delay, Negative-Going $\overline{\text{CPSI}}$ to $\overline{\text{IRF}}$ Output	1.5	20.0	1.5	21.0	ns	Figure 11 Figure 12
t_{PLH}	Propagation Delay, Negative-Going $\overline{\text{TTS}}$ to $\overline{\text{IRF}}$	1.5	36.0	1.5	38.0		
t_{PLH} t_{PHL}	Propagation Delay, Negative-Going $\overline{\text{CPSO}}$ to $\overline{\text{Q}_5}$ Output	1.5	28.0	1.5	29.0	ns	Figure 13 Figure 14
t_{PLH} t_{PHL}	Propagation Delay, Positive-Going $\overline{\text{TOP}}$ to Outputs $\overline{\text{Q}_0}$ - $\overline{\text{Q}_3}$	1.5	46.0	1.5	48.0		
t_{PHL}	Propagation Delay, Negative-Going $\overline{\text{CPSO}}$ to $\overline{\text{ORE}}$	1.5	35.0	1.5	37.0	ns	Figure 13 Figure 14
t_{PHL}	Propagation Delay, Negative-Going $\overline{\text{TOP}}$ to $\overline{\text{ORE}}$	1.5	37.0	1.5	39.0		
t_{PLH}	Propagation Delay, Positive-Going $\overline{\text{TOP}}$ to $\overline{\text{ORE}}$	1.5	47.0	1.5	49.0	ns	Figure 13 Figure 14
t_{PLH}	Propagation Delay, Negative-Going $\overline{\text{TOS}}$ to Positive Going $\overline{\text{ORE}}$	1.5	42.5	1.5	45.0		
t_{PLH}	Propagation Delay, Positive-Going $\overline{\text{PL}}$ to Negative-Going $\overline{\text{IRF}}$	1.5	28.0	1.5	29.0	ns	Figure 17 Figure 18
t_{PLH}	Propagation Delay, Negative-Going $\overline{\text{PL}}$ to Positive-Going $\overline{\text{IRF}}$	1.5	24.0	1.5	25.0		

AC Electrical Characteristics							
Symbol	Parameter	T _A = +25°C		T _A = 0°C to +70°C		Units	Figure Number
		V _{CC} = +5.0V C _L = 50 pF		V _{CC} = +5.0V C _L = 50 pF			
		Min	Max	Min	Max		
t _{PLH}	Propagation Delay, Positive-Going OES to ORE	1.5	39.5	1.5	41.0	ns	
t _{PLH}	Propagation Delay, Positive-Going IES to Positive-Going IRF	1.5	20.0	1.5	21.0	ns	Figure 18
t _{PLH}	Propagation Delay, MR to IRF	1.5	20.0	1.5	20.0	ns	
t _{PHL}	Propagation Delay, MR to ORE	1.5	33.0	1.5	35.0	ns	
t _{PZH}	Propagation Delay, OE to Q ₀ , Q ₁ , Q ₂ , Q ₃	1.5	14.0	1.5	14.0	ns	
t _{PZL}	Propagation Delay, OE to Q ₀ , Q ₁ , Q ₂ , Q ₃	1.5	14.0	1.5	14.0		
t _{PHZ}	Propagation Delay, Negative-Going OES to Q _S	1.5	16.5	1.5	17.0	ns	
t _{PZL}	Propagation Delay, Negative-Going OES to Q _S	1.5	17.0	1.5	17.0		
t _{PHZ}	Propagation Delay, Negative-Going OES to Q _S	1.5	14.0	1.5	14.0	ns	
t _{PLZ}	Propagation Delay, Negative-Going OES to Q _S	1.5	14.0	1.5	14.0		
t _{PZH}	Turn On Time TOS to Q _S	1.5	60.0	1.5	60.0	ns	
t _{PZL}	Turn On Time TOS to Q _S	1.5	60.0	1.5	60.0		
t _{DFT}	Fall Through Time		500		500	ns	Figure 16
t _{AP}	Parallel Appearance Time, ORE to Q ₀ -Q ₃	-19.0	6.5	-20.0	7.0	ns	
t _{AS}	Serial Appearance Time, ORE to Q _S	-9.5	14.5	-10.0	15.0		
t _{DBU}	Bubble-Up Time		470		500	ns	

AC Operating Requirements							
Symbol	Parameter	$T_A = +25^\circ\text{C}$ $V_{CC} = +5.0\text{V}$		$T_A = 0^\circ\text{C to } +70^\circ\text{C}$ $V_{CC} = +5.0\text{V}$		Units	Figure Number
		Min	Max	Min	Max		
t_S (H)	Setup Time, HIGH or LOW	15.5		16.0		ns	Figure 11 Figure 12
t_S (L)	D_S to Negative $\overline{\text{CPSI}}$	15.5		16.0			
t_H (H)	Hold Time, HIGH or LOW	2.0		2.0		ns	Figure 12
t_H (L)	D_S to $\overline{\text{CPSI}}$	2.0		2.0			
t_S (L)	Set-Time, LOW Negative-Going $\overline{\text{IES}}$ to $\overline{\text{CPSI}}$	18.0		18.0		ns	Figure 12
t_S (L)	Set-Up Time, LOW Negative-Going $\overline{\text{TTS}}$ to $\overline{\text{CPSI}}$	65.0		70.0		ns	Figure 12
t_S (H)	Set-Up time, HIGH or LOW	0		0		ns	
t_S (L)	Parallel Inputs to PL	0		0			
t_H (H)	Hold Time, HIGH or LOW	0		0			
t_H (L)	Parallel Inputs to PL	0		0			
t_W (H)	CPSI Pulse Width	30		32		ns	Figure 11
t_W (L)	HIGH or LOW	20		20		ns	Figure 12
t_W (H)	PL Pulse Width, HIGH	16.5		17.0		ns	Figure 17 Figure 18
t_W (L)	TTS Pulse Width, LOW Serial or Parallel Mode	16.0		17.0		ns	Figure 11 Figure 12 Figure 13 Figure 14
t_W (L)	MR Pulse Width, LOW	15.0		15.0		ns	Figure 16
t_W (H)	TOP Pulse Width	15.0		17.0		ns	Figure 15
t_W (L)	HIGH or LOW	15.0		15.0			
t_W (H)	CPSO Pulse Width	17.0		17.0		ns	Figure 13
t_W (L)	HIGH or LOW	17.0		18.0		ns	Figure 14
t_{REC}	Recovery Time MR to Any Input	16.5		19.0		ns	Figure 16

Timing Waveforms

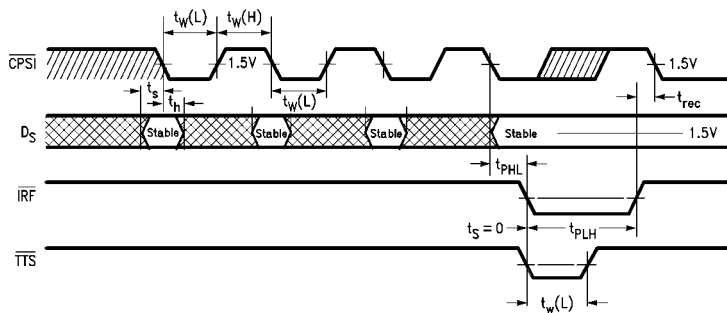

Conditions: stack not full, \overline{IES} , PL LOW

FIGURE 11. Serial Input, Unexpanded or Master Operation

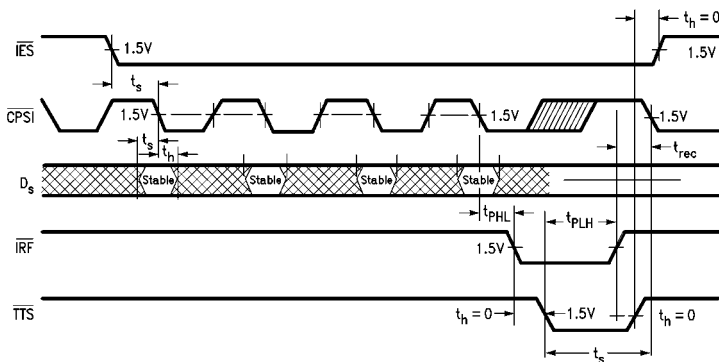

Conditions: stack not full, \overline{IES} HIGH when initiated, PL LOW

FIGURE 12. Serial Input, Expanded Slave Operation

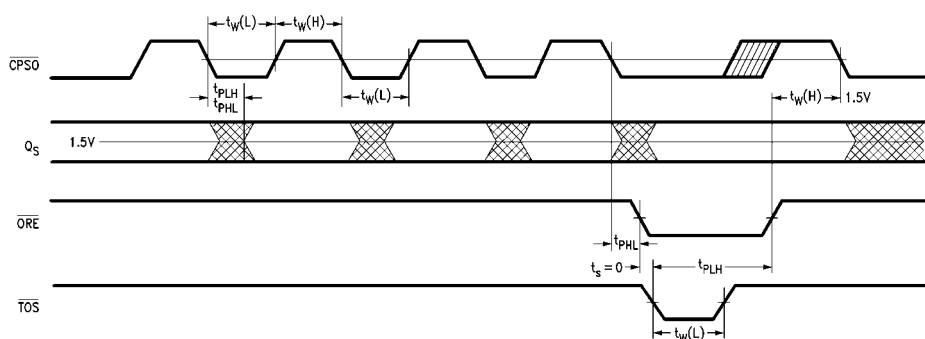

Conditions: data in stack, TOP HIGH, \overline{IES} LOW when initiated, \overline{OES} LOW

FIGURE 13. Serial Output, Unexpanded or Master Operation

Timing Waveforms (Continued)

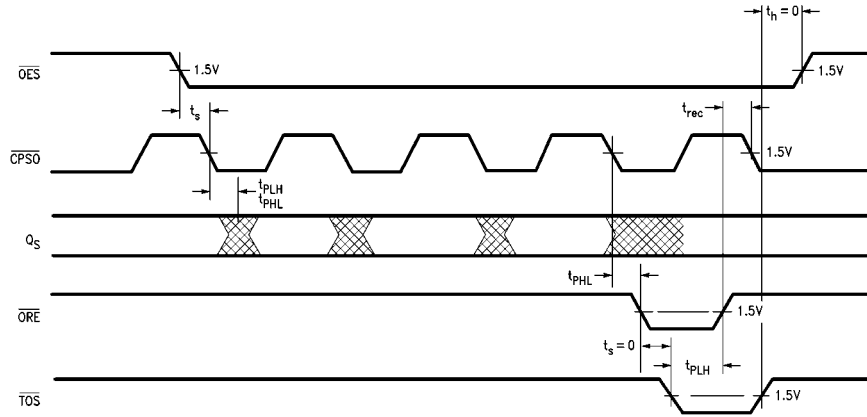

Conditions: data in stack, TOP HIGH, IES HIGH when initiated

FIGURE 14. Serial Output, Slave Operation

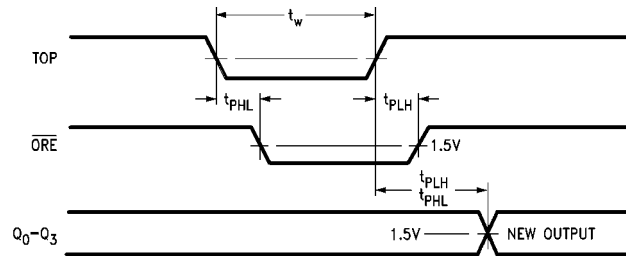

Conditions: IES LOW when initiated, OE, CPSO LOW; data available in stack

FIGURE 15. Parallel Output, 4-Bit Word or Master in Parallel Expansion

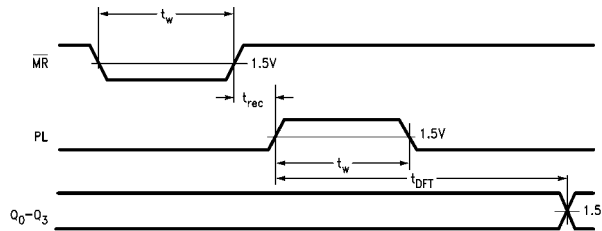

Conditions: TTS connected to IRF, TOS connected to ORE, IES, OES, OE, CPSO LOW, TOP HIGH

FIGURE 16. Fall Through Time

Timing Waveforms (Continued)

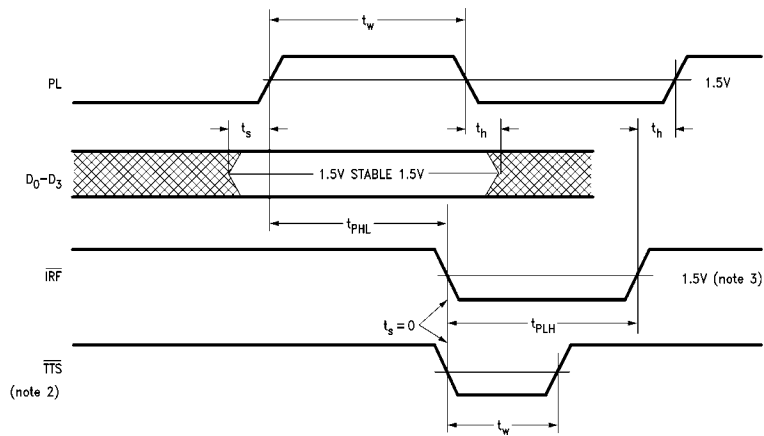

Conditions: stack not full, $\overline{\text{IES}}$ LOW when initialized

FIGURE 17. Parallel Load Mode, 4-Bit Word (Unexpanded) or Master in Parallel Expansion

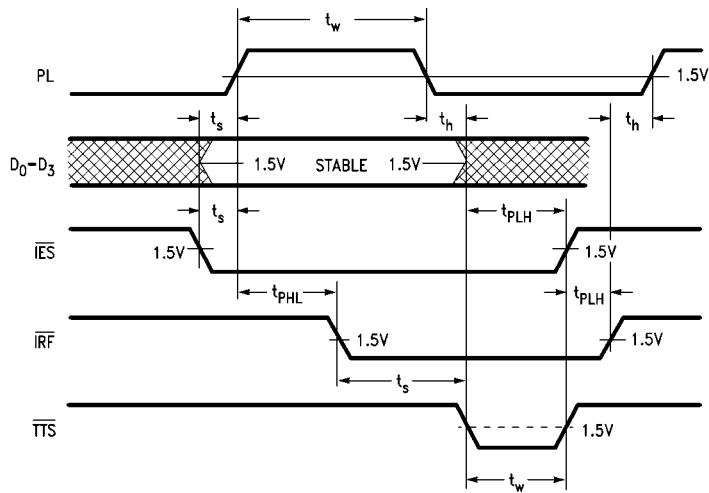

Conditions: stack not full, device initialized (Note 3) with $\overline{\text{IES}}$ HIGH

FIGURE 18. Parallel Load, Slave Mode

Note 3: Initialization requires a master reset to occur after power has been applied.

Note 4: $\overline{\text{TTS}}$ normally connected to $\overline{\text{IRF}}$.

Note 5: If stack is full, $\overline{\text{IRF}}$ will stay LOW.

Physical Dimensions inches (millimeters) unless otherwise noted

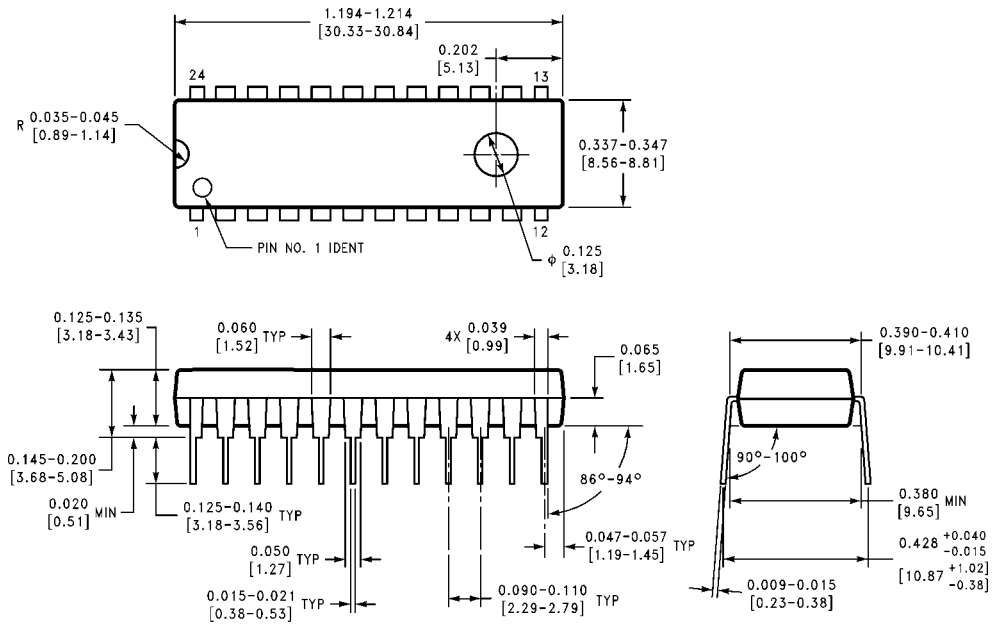

**24-Lead Plastic Dual-In-Line Package (PDIP), JEDEC MS-011, 0.400 Wide
Package Number N24E**

N24E (REV A)

LIFE SUPPORT POLICY

FAIRCHILD'S PRODUCTS ARE NOT AUTHORIZED FOR USE AS CRITICAL COMPONENTS IN LIFE SUPPORT DEVICES OR SYSTEMS WITHOUT THE EXPRESS WRITTEN APPROVAL OF THE PRESIDENT OF FAIRCHILD SEMICONDUCTOR CORPORATION. As used herein:

1. Life support devices or systems are devices or systems which, (a) are intended for surgical implant into the body, or (b) support or sustain life, and (c) whose failure to perform when properly used in accordance with instructions for use provided in the labeling, can be reasonably expected to result in a significant injury to the user.
2. A critical component in any component of a life support device or system whose failure to perform can be reasonably expected to cause the failure of the life support device or system, or to affect its safety or effectiveness.

www.fairchildsemi.com