

High-voltage switching Transistor

2SC4061K / 2SC3415S / 2SC4015 / 2SC3271F

●Features

- 1) High breakdown voltage. ($BV_{CEO}=300V$)
- 2) Low collector output capacitance. (Typ. 3pF at $V_{CB}=30V$)
- 3) Ideal for surge protection on telephone lines.

●Packaging specifications and h_{FE}

Type	2SC4061K	2SC3415S	2SC4015	2SC3271F
Package	SMT3	SPT	ATV	TO-126F
h_{FE}	NP	NP	N	N
Marking	AN*	—	—	—
Code	T146	TP	TV2	—
Basic ordering unit (pieces)	3000	5000	2500	1000

* Denotes h_{FE}

●Absolute maximum ratings ($T_a=25^\circ C$)

Parameter	Symbol	Limits	Unit
Collector-base voltage	V_{CBO}	300	V
Collector-emitter voltage	V_{CEO}	300	V
Emitter-base voltage	V_{EBO}	5	V
Collector current	I_C	100	mA
Collector power dissipation	P_C	0.2	W
		0.3	
		1	
		1.2	
		5	
Junction temperature	T_J	150	$^\circ C$
Storage temperature	T_{stg}	-55~150	$^\circ C$

* Printed circuit board 1.7mm thick, collector plating 1cm² or larger.

●Electrical characteristics ($T_a=25^\circ C$)

Parameter	Symbol	Min.	Typ.	Max.	Unit	Conditions
Collector-base breakdown voltage	BV_{CBO}	300	—	—	V	$I_C=50 \mu A$
Collector-emitter breakdown voltage	BV_{CEO}	300	—	—	V	$I_C=100 \mu A$
Emitter-base breakdown voltage	BV_{EBO}	5	—	—	V	$I_E=50 \mu A$
Collector cutoff current	I_{CBO}	—	—	0.5	μA	$V_{CB}=200V$
Emitter cutoff current	I_{EBO}	—	—	0.5	μA	$V_{EB}=4V$
Collector-emitter saturation voltage	$V_{CE(sat)}$	—	—	2	V	$I_C/I_E=50mA/5mA$
DC current transfer ratio	2SC4061K, 2SC3415S	56	—	180	—	$V_{CE}/I_C=10V/10mA$
	2SC4015, 2SC3271F	56	—	120	—	
Gain bandwidth product	f_T	50	100	—	MHz	$V_{CE}=30V, I_E=-10mA, f=100MHz$
Collector output capacitance	C_{ob}	—	3	—	pF	$V_{CB}=30V, I_E=0A, f=1MHz$

(96-172-C52)

High-voltage Switching Transistor (Power supply)

2SC4938 / 2SC4129

●Features

- 1) Low $V_{CE(sat)}$. (Typ. 0.6V at $I_C/I_E=5/1A$)
- 3) Fast switching (t_f : Max. 1 μs at $I_C=4A$)
- 3) Wide SOA (safe operating area).

●Packaging specifications and h_{FE}

Type	2SC4938	2SC4129
Package	PSD3	TO-220FP
h_{FE}	B	AB
Code	TL	—
Basic ordering unit (pieces)	1000	500

●Absolute maximum ratings ($T_a=25^\circ C$)

Parameter	Symbol	Limits	Unit
Collector-base voltage	V_{CBO}	400	V
Collector-emitter voltage	V_{CEO}	400	V
Emitter-base voltage	V_{EBO}	7	V
Collector current	I_C	5	A
	I_{CP}	7	A *
Collector power dissipation	P_C	1.5	W
		35	
		30	
Junction temperature	T_J	150	$^\circ C$
Storage temperature	T_{stg}	-55~150	$^\circ C$

* Single pulse $P_w=100ms$

●Electrical characteristics ($T_a=25^\circ C$)

Parameter	Symbol	Min.	Typ.	Max.	Unit	Conditions
Collector-base breakdown voltage	BV_{CBO}	400	—	—	V	$I_C=50 \mu A$
Collector-emitter breakdown voltage	BV_{CEO}	400	—	—	V	$I_C=1mA$
Emitter-base breakdown voltage	BV_{EBO}	7	—	—	V	$I_E=50 \mu A$
Collector cutoff current	I_{CBO}	—	—	10	μA	$V_{CB}=400V$
Emitter cutoff current	I_{EBO}	—	—	10	μA	$V_{EB}=5V$
Collector-emitter saturation voltage	$V_{CE(sat)}$	—	—	1	V	$I_C/I_E=5A/1A$ *
Collector-emitter saturation voltage	$V_{BE(sat)}$	—	—	1.5	V	$I_C/I_E=5A/1A$ *
DC current transfer ratio	2SC4938	25	—	50	—	$V_{CE}/I_C=5V/2A$
	2SC4129	16	—	50	—	
Transition frequency	f_T	—	15	—	MHz	$V_{CB}=10V, I_E=-0.5A, f=5MHz$ *
Output capacitance	C_{ob}	—	80	—	pF	$V_{CE}=10V, I_E=0A, f=1MHz$
Turn-on time	t_{on}	—	—	1	μs	$I_C=4A, R_L=50 \Omega$
Storage time	t_{stg}	—	—	2.5	μs	$I_{B1}=-I_{B2}=0.4A$
Fall time	t_f	—	—	1	μs	$V_{CC}=200V$

* Measured using pulse current.

Bi-polar transistors

7828999 0016960 385



(96-188-C55)

295

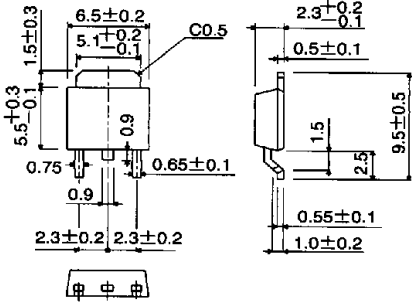
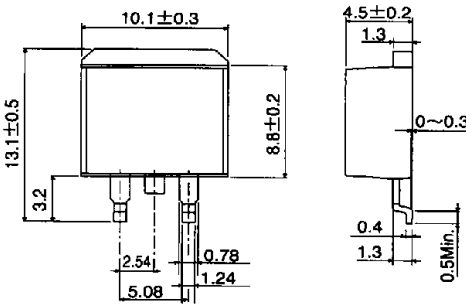
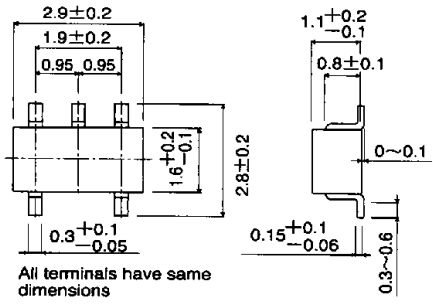
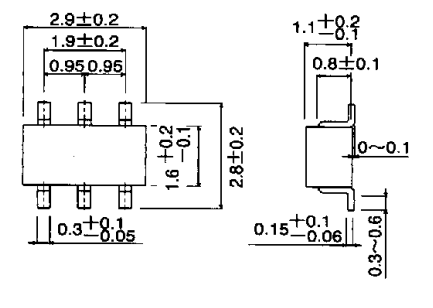
Type	External dimensions (Units : mm)	Features
<p>CPT 3 SC-63 type</p>	 <p>Technical drawing of CPT 3 SC-63 type transistor. Top view dimensions: 6.5±0.2, 5.1±0.2, 0.9, 0.75, 0.9, 2.3±0.2, 2.3±0.2. Side view dimensions: 2.3±0.2, 0.5±0.1, 1.5, 2.5, 9.5±0.5, 0.55±0.1, 1.0±0.2. Lead angle: C0.5.</p>	<p>By itself the CPT3 has a P_c of 1 W ($T_a = 25^\circ\text{C}$), but a large P_c of several watts can be obtained with an appropriate mounting surface. At the same time the CPT3 is compact, making it suitable for high density mounting and hybrid ICs. Available on tape for automatic mounting. For vertical high density mounting, the leaded CPT (SC-64) type with the same mold size is also available.</p>
<p>PSD3</p>	 <p>Technical drawing of PSD3 transistor. Top view dimensions: 10.1±0.3, 13.1±0.5, 8.6±0.2, 3.2, 2.54, 0.78, 5.08, 1.24. Side view dimensions: 4.5±0.2, 1.3, 0~0.3, 0.4, 1.3, 0.5Min.</p>	<p>The PSD3 is a TO-220 class surface-mount package. A high P_c can be obtained with an appropriate mounting surface. Surface mounting allows a high vertical density, enabling the design of slim and compact devices. The PSD3 is available on tape for automatic mounting, and it helps improve mounting efficiency and reduce mounting cost.</p>
<p>SMT5 SC-74A type</p>	 <p>Technical drawing of SMT5 SC-74A type transistor. Top view dimensions: 2.9±0.2, 1.9±0.2, 0.95, 0.95, 1.6±0.1, 2.8±0.2, 0.3±0.1, 0.05. Side view dimensions: 1.1±0.2, 0.1, 0.8±0.1, 0~0.1, 0.15±0.1, 0.06, 0.3~0.6.</p> <p>All terminals have same dimensions</p>	<p>The SMT5 consists of two connected transistors or digital transistors in an SMT3 (SC-59) package. The mounting area can be reduced by 50% compared to the SMT3 and the internal circuitry is complete, making this package ideal for high density mounting at half the assembly cost.</p>
<p>SMT6 SC-74 type</p>	 <p>Technical drawing of SMT6 SC-74 type transistor. Top view dimensions: 2.9±0.2, 1.9±0.2, 0.95, 0.95, 1.6±0.1, 2.8±0.2, 0.3±0.1, 0.05. Side view dimensions: 1.1±0.2, 0.1, 0.8±0.1, 0~0.1, 0.15±0.1, 0.06, 0.3~0.6.</p>	<p>The SMT6 consists of two independent transistors or two independent digital transistors in an SMT3 (SC-59) package. The mounting area and mounting cost can be reduced by 50% compared to the SMT3, and the two transistors are independent to allow free configuration of a high density circuit.</p>

EXPLANATION

7828999 0016710 T98

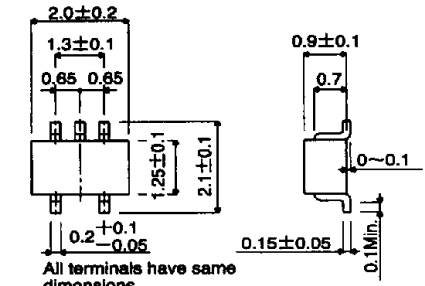
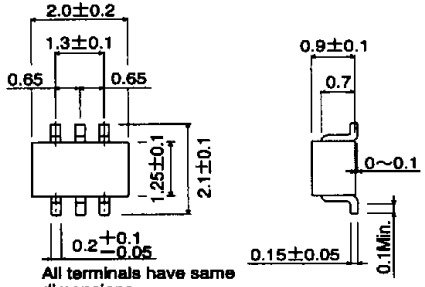
Type	External dimensions (Units : mm)	Features
<p>UMT5 SC-88A type</p>	 <p>All terminals have same dimensions</p>	<p>The UMT5 consists of two connected transistors or digital transistors in a UMT3 (SC-70) package. The mounting area can be reduced by 50% compared to the UMT3 and the internal circuitry is completed, making this package ideal for high density mounting at half the assembly cost.</p>
<p>UMT6 SC-88 type</p>	 <p>All terminals have same dimensions</p>	<p>The UMT6 consists of two independent transistors or two independent digital transistors in a UMT (SC-70) package. The mounting area and mounting cost can be reduced by 50% compared to the UMT3, and the two transistors are independent to allow free configuration of a high density circuit.</p>

●Types and features of leaded packages

Type	External dimensions (Units : mm)	Features
<p>SPT (SC-72 type)</p>		<p>The SPT is a smaller version of the conventional TO-92 type. The body size (3×4×2 mm³) has been reduced to 1/4 that of the TO-92 (5×5×4 mm³). The SPT is available on tape for automatic insertion, and less space is occupied on the printed circuit board than the TO-92. Reliability is the same as the TO-92.</p>
<p>FTR</p>		<p>SIL type with a height of 3.4 mm and a lead pitch of 2.54 mm.</p>
<p>FTL</p>		<p>The FTL is a radial taping version of the highly popular FTR. This enables automatic high-density mounting with a radial insertion machine.</p>
<p>ATR (SC-71 type)</p>		<p>SC-71type with a height of 4.4 mm and a P_c=1W type.</p>

EXPLANATION

7828999 0016712 860

Type	External dimensions (Units : mm)	Features
ATV		<p>The ATV is a radial tapering version of the highly popular ATR. This enables automatic high-density mounting with a radial insertion machine.</p>
TO-92 (SC-43 type)		<p>The SC-43 is for general purpose small signals.</p>
TO-126FP		<p>The TO-126FP is an isolation type package based on a TO-126 full mold. In addition to the features of the TO-126, molded heat sink fins allow easy isolation of the heat sink.</p>
TO-220FP (SC-67 type)		<p>The TO-220FP is an isolation type package based on a TO-220 full mold. In addition to the features of the TO-126 and TO-220, molded heat sink fins allow easy isolation of the heat sink.</p>

7828999 0016713 7T7

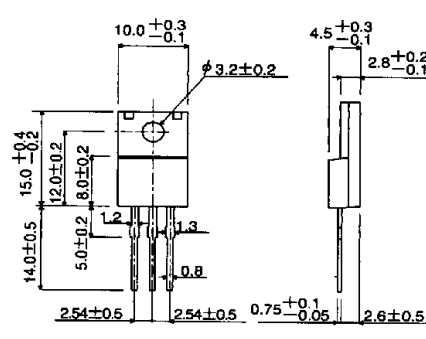
Type	External dimensions (Units : mm)	Features
TO-220FN	 <p>Technical drawing of the TO-220FN transistor showing front and side views with dimensions in millimeters. The front view shows a top diameter of $10.0^{+0.3}_{-0.1}$ mm, a hole diameter of $\phi 3.2 \pm 0.2$ mm, and a total height of $15.0^{+0.4}_{-0.2}$ mm. The side view shows a total height of $4.5^{+0.3}_{-0.1}$ mm and a diameter of $2.8^{+0.2}_{-0.1}$ mm. Other dimensions include 12.0 ± 0.2, 8.0 ± 0.2, 14.0 ± 0.5, 5.0 ± 0.2, 1.2, 1.3, 0.8, 2.54 ± 0.5, $0.75^{+0.1}_{-0.05}$, and 2.6 ± 0.5.</p>	<p>The TO-220FN features the same performance as the TO-220FP with approximately 2 mm less height, allowing the design of slimmer devices. Furthermore, the elimination of support pins in the fin (collector electrode) solves short-circuiting problems with neighboring components and the chassis.</p> <p>To make the height to the installation hole the same as the TO-220FP, it can be replaced as is from the TO-220FP.</p>

EXPLANATION

7828999 0016714 633