

2SB1390

Silicon PNP Triple Diffused
Low Frequency Power Amplifier

Absolute Maximum Ratings (Ta = 25°C)

Item	Symbol	Rating	Unit
Collector to base voltage	V_{CB0}	-60	V
Collector to emitter voltage	V_{CE0}	-60	V
Emitter to base voltage	V_{EB0}	-7	V
Collector current	I_C	-8	A
Collector peak current	$i_{C(\text{peak})}$	-12	A
Collector power dissipation	P_C	2	W
	P_C^{*1}	25	
Junction temperature	T_j	150	°C
Storage temperature	T_{stg}	-55 to +150	°C
C to E diode forward current	I_D^{*1}	8	A

Note: 1. Value at $T_C = 25^\circ\text{C}$.

TO-220 FM



1. Base
2. Collector
3. Emitter

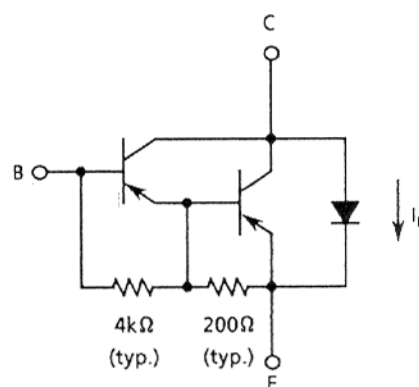

Electrical Characteristics (Ta = 25°C)

Item	Symbol	Min	Typ	Max	Unit	Test condition
Collector to base breakdown voltage	$V_{(BR)CB0}$	-60	—	—	V	$I_C = -0.1 \text{ mA}$, $I_E = 0$
Collector to emitter breakdown voltage	$V_{(BR)CE0}$	-60	—	—	V	$I_C = -25 \text{ mA}$, $R_{BE} = \infty$
Emitter to base breakdown voltage	$V_{(BR)EB0}$	-7	—	—	V	$I_E = -50 \text{ mA}$, $I_C = 0$
Collector cutoff current	I_{CB0}	—	—	-10	μA	$V_{CB} = -50 \text{ V}$, $I_E = 0$
	I_{CE0}	—	—	-10		$V_{CE} = -50 \text{ V}$, $R_{BE} = \infty$
DC current transfer ratio	h_{FE}	1000	—	20000		$V_{CE} = -3 \text{ V}$, $I_C = -4 \text{ A}^{*1}$
Collector to emitter saturation voltage	$V_{CE(\text{sat})1}$	—	—	-1.5	V	$I_C = -4 \text{ A}$, $I_B = -8 \text{ mA}^{*1}$
	$V_{CE(\text{sat})2}$	—	—	-3.0		$I_C = -8 \text{ A}$, $I_B = -80 \text{ mA}^{*1}$

Electrical Characteristics (Ta = 25°C) (cont)

Item	Symbol	Min	Typ	Max	Unit	Test condition
Base to emitter saturation voltage	$V_{BE(sat)1}$	—	—	-2.0	V	$I_C = -4\text{ A}, I_B = -8\text{ mA}^{-1}$
	$V_{BE(sat)2}$	—	—	-3.5		$I_C = -8\text{ A}, I_B = -80\text{ mA}^{-1}$
C to E diode forward voltage	V_D	—	—	3.0	V	$I_D = 8\text{ A}^{-1}$

Note: 1. Pulse Test.
See switching characteristic curve of 2SB1103.

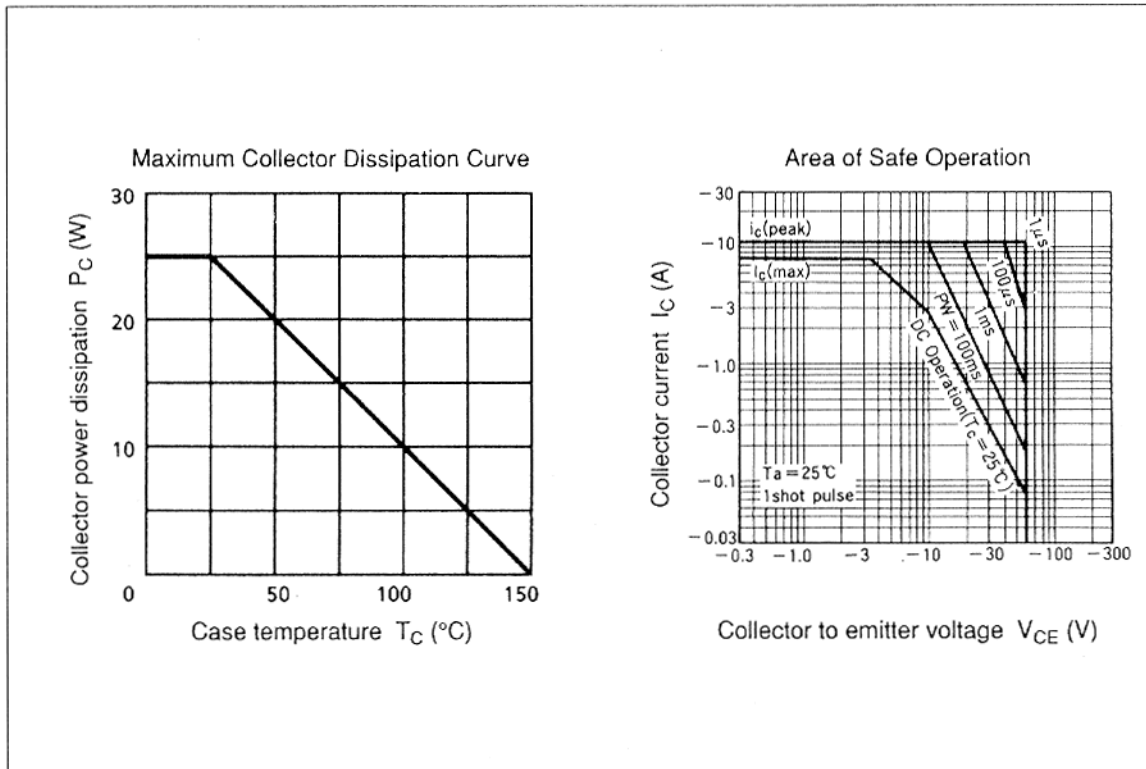

2SB1390

Typical Output Characteristics

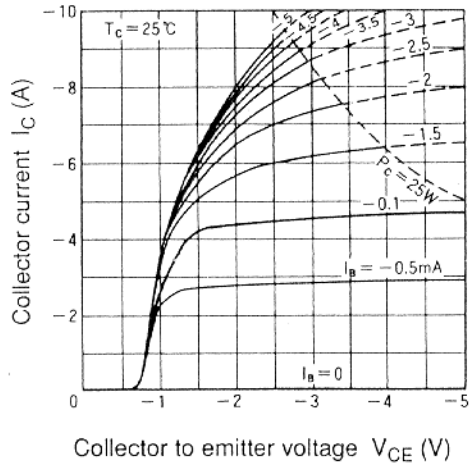

DC Current Transfer Ratio vs. Collector Current

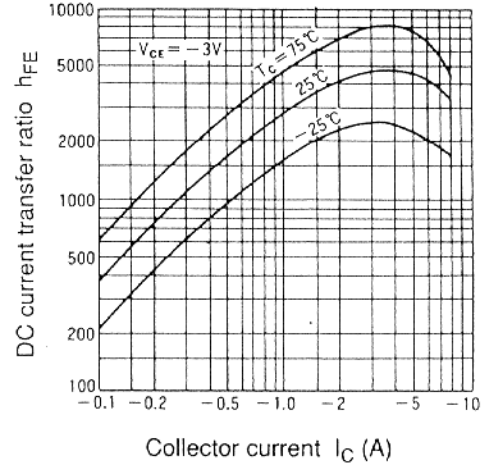

Saturation Voltage vs. Collector Current

