

2SB1399

Silicon PNP Triple Diffused
Low Frequency Power Amplifier

Absolute Maximum Ratings (Ta = 25°C)

Item	Symbol	Rating	Unit
Collector to base voltage	V_{CBO}	-120	V
Collector to emitter voltage	V_{CEO}	-120	V
Emitter to base voltage	V_{EBO}	-7	V
Collector current	I_C	-10	A
Collector peak current	$i_{C(peak)}$	-15	A
Collector power dissipation	P_C	2	W
	P_C^{*1}	30	
Junction temperature	T_j	150	°C
Storage temperature	T_{stg}	-55 to +150	°C
C to E diode forward current	I_D^{*1}	10	A

Note: 1. Value at $T_C = 25^\circ\text{C}$.

TO-220 FM



1. Base
2. Collector
3. Emitter

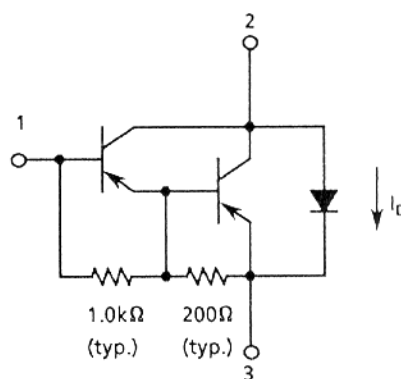

Electrical Characteristics (Ta = 25°C)

Item	Symbol	Min	Typ	Max	Unit	Test condition
Collector to base breakdown voltage	$V_{(BR)CBO}$	-120	—	—	V	$I_C = -0.1 \text{ mA}, I_E = 0$
Collector to emitter breakdown voltage	$V_{(BR)CEO}$	-120	—	—	V	$I_C = -25 \text{ mA}, R_{BE} = \infty$
Emitter to base breakdown voltage	$V_{(BR)EBO}$	-7	—	—	V	$I_E = -50 \text{ mA}, I_C = 0$
Collector cutoff current	I_{CBO}	—	—	-10	μA	$V_{CB} = -100 \text{ V}, I_E = 0$
	I_{CEO}	—	—	-10		$V_{CE} = -100 \text{ V}, R_{BE} = \infty$
DC current transfer ratio	h_{FE}	1000	—	20000		$V_{CE} = -3 \text{ V}, I_C = -5 \text{ A}^{*1}$
Collector to emitter saturation voltage	$V_{CE(sat)1}$	—	—	-1.5	V	$I_C = -5 \text{ A}, I_B = -10 \text{ mA}^{*1}$
	$V_{CE(sat)2}$	—	—	-3.0		$I_C = -10 \text{ A}, I_B = -100 \text{ mA}^{*1}$

Electrical Characteristics (Ta = 25°C) (cont)

Item	Symbol	Min	Typ	Max	Unit	Test condition
Base to emitter saturation voltage	$V_{BE(sat)1}$	—	—	-2.0	V	$I_C = -5\text{ A}, I_B = -10\text{ mA}^1$
	$V_{BE(sat)2}$	—	—	-3.5		$I_C = -10\text{ A}, I_B = -100\text{ mA}^1$
C to E diode forward voltage	V_D	—	—	3.0	V	$I_D = 10\text{ A}^1$

Note: 1. Pulse Test.

See switching characteristic curve of 2SB955(K).

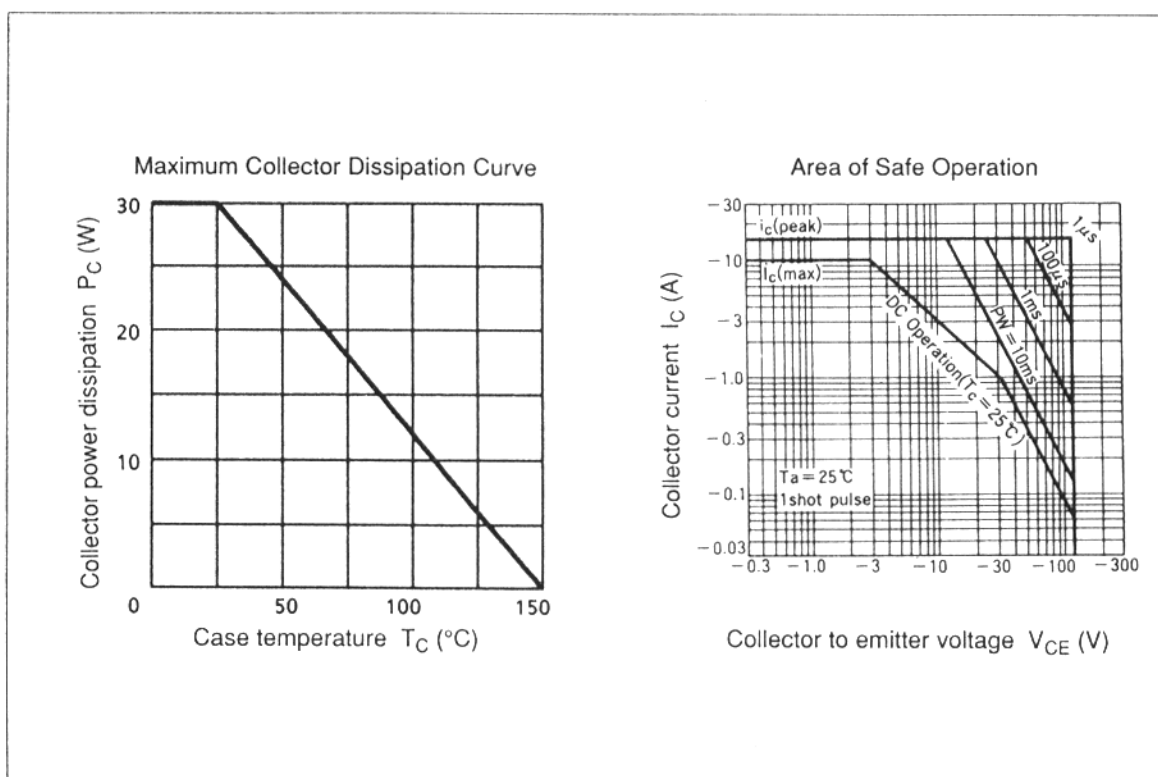

2SB1399

Typical Output Characteristics

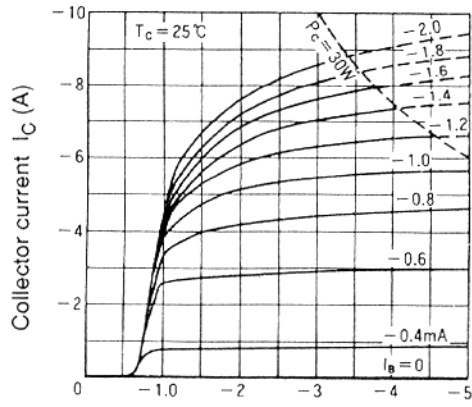

Collector to emitter voltage V_{CE} (V)

DC Current Transfer Ratio vs. Collector Current

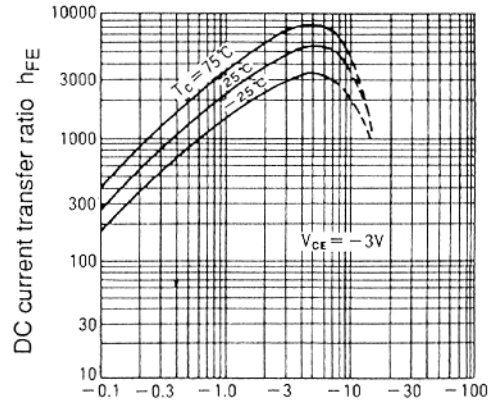

Saturation Voltage vs. Collector Current

