

## 2SC1881 (K)

**Silicon NPN Triple Diffused  
High Gain Amplifier Power Switching**

### Absolute Maximum Ratings (Ta = 25°C)

Item	Symbol	Rating	Unit
Collector to base voltage	$V_{CBO}$	60	V
Collector to emitter voltage	$V_{CEO}$	60	V
Emitter to base voltage	$V_{EBO}$	7	V
Collector current	$I_C$	3	A
Collector peak current	$i_{C(peak)}$	6	A
Collector power dissipation	$P_C^{*1}$	30	W
Junction temperature	$T_j$	150	°C
Storage temperature	$T_{stg}$	-55 to +150	°C

Note: 1. Value at  $T_C = 25^\circ\text{C}$ .

### Electrical Characteristics (Ta = 25°C)

Item	Symbol	Min	Typ	Max	Unit	Test condition
Collector to emitter breakdown voltage	$V_{(BR)CEO}$	60	—	—	V	$I_C = 50 \text{ mA}$ , $R_{BE} = \infty$
Emitter to base breakdown voltage	$V_{(BR)EBO}$	7	—	—	V	$I_E = 50 \text{ mA}$ , $I_C = 0$
Collector cutoff current	$I_{CBO}$	—	—	0.2	mA	$V_{CB} = 60 \text{ V}$ , $I_E = 0$
	$I_{CEO}$	—	—	0.4	mA	$V_{CE} = 30 \text{ V}$ , $R_{BE} = \infty$
DC current transfer ratio	$h_{FE}$	1000	—	—		$V_{CE} = 1.5 \text{ V}$ , $I_C = 1.5 \text{ A}^{*1}$
		500	—	—		$I_C = 2.5 \text{ A}^{*1}$
Collector to emitter saturation voltage	$V_{CE(sat)}$	—	—	1.2	V	$I_C = 2.5 \text{ A}$ , $I_B = 20 \text{ mA}^{*1}$
Turn on time	$t_{on}$	—	1	—	$\mu\text{s}$	$V_{CC} = 11 \text{ V}$ , $I_C = 2 \text{ A}$ , $I_{B1} = -I_{B2} = 8 \text{ mA}$
Turn off time	$t_{off}$	—	5	—	$\mu\text{s}$	

Note: 1. Pulse Test.

TO-220AB

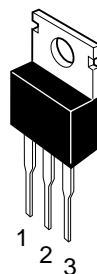

1. Base
2. Collector (Flange)
3. Emitter

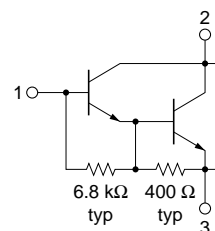

Maximum Collector Dissipation Curve

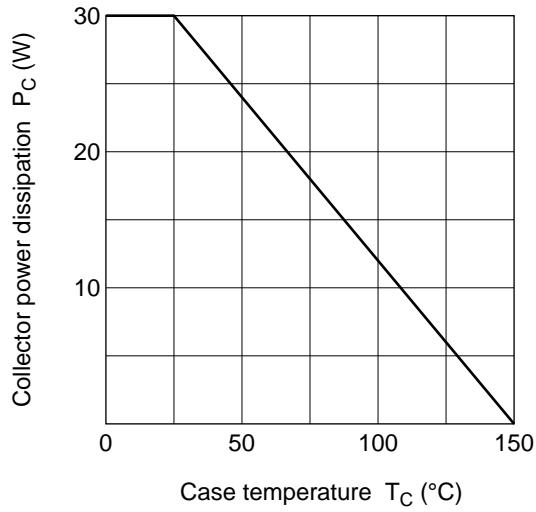

Area of Safe Operation

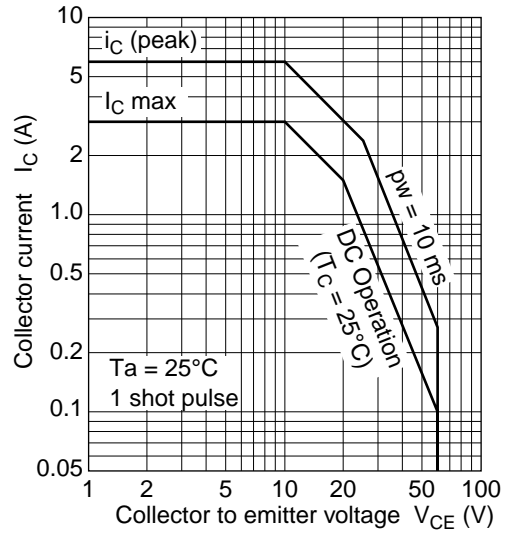

Typical Output Characteristics

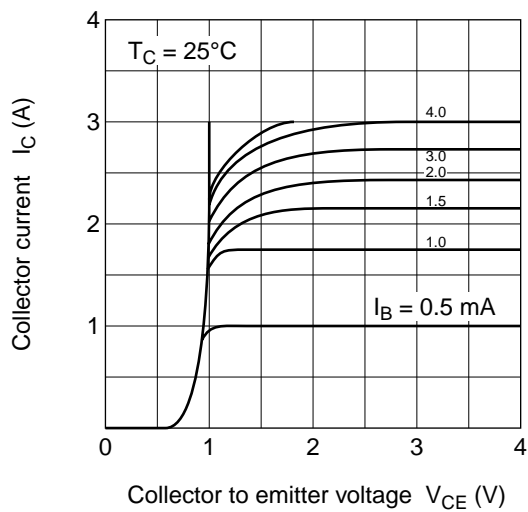

DC Current Transfer Ratio vs. Collector Current

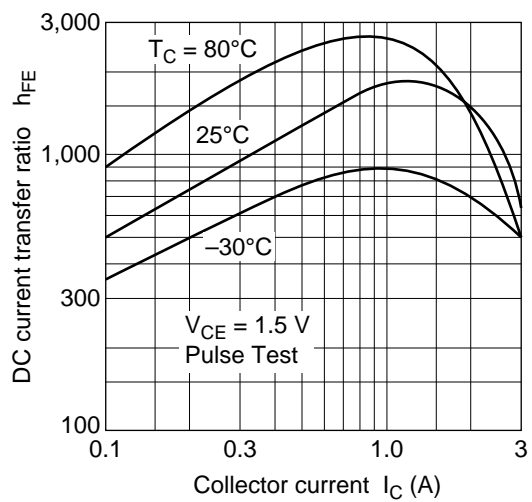

Collector to Emitter Saturation Voltage  
vs. Collector Current

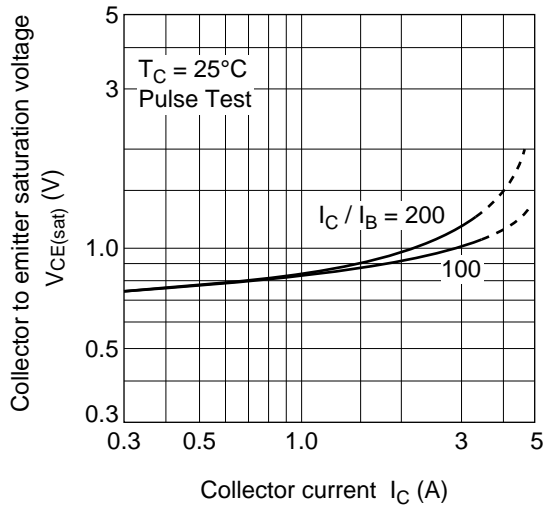

Switching Time Test Circuit

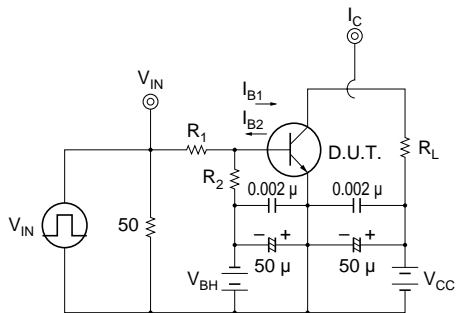

$t_r, t_f \leq 10 \text{ ns}$   
 $\text{pw} \geq 100 \mu\text{s}$   
duty ratio  $\leq 10\%$

Unit R :  $\Omega$   
C : F

Response Waveform

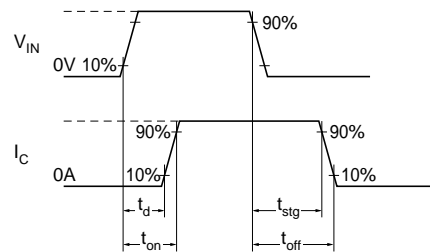

$I_C$	$I_{B1}$	$I_{B2}$	$V_{CC}$	$V_{BB}$	$V_{IN}$	$R_L$	$R_1$	$R_2$
A	mA	mA	V	V	V	$\Omega$	$\Omega$	$\Omega$
2	8	-8	11	-4	7.2	5	620	910