

6A
(NPN) **2SC4311**
(TP6V80HDT)

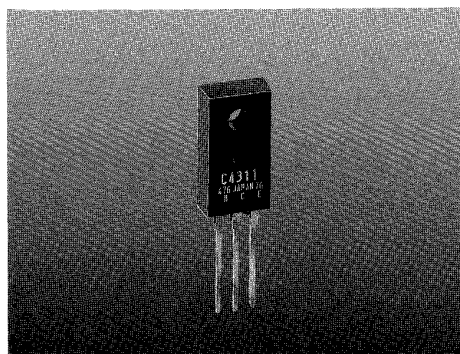

■外形寸法図 Outline Dimensions

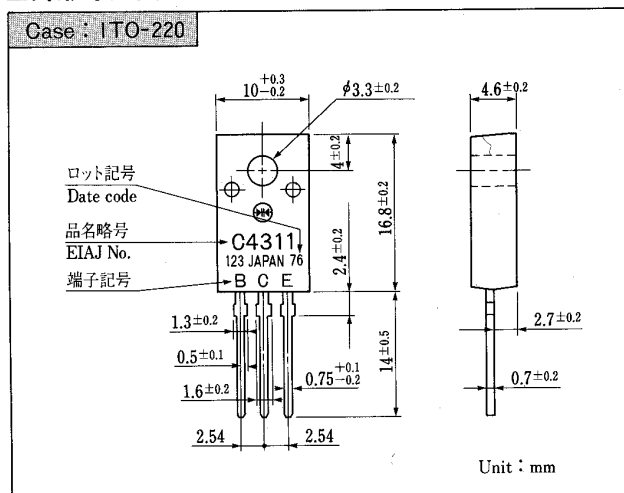

■絶対最大定格 Absolute Maximum Ratings

項目 Item	記号 Symbol	条件 Conditions	規格値 Ratings	単位 Unit
保存温度 Storage Temperature	T _{stg}		-55~150	°C
接合部温度 Junction Temperature	T _j		150	°C
コレクタ・ベース電圧 Collector to Base Voltage	V _{CB0}		900	V
コレクタ・エミッタ電圧 Collector to Emitter Voltage	V _{CE0}		800	V
エミッタ・ベース電圧 Emitter to Base Voltage	V _{EB0}		7	V
コレクタ電流 Collector Current	DC	I _c	6	A
	Peak	I _{cP}	12	
ベース電流 Base Current	DC	I _b	3	A
	Peak	I _{bP}	6	
トランジスタ損失 Total Transistor Dissipation	P _T	T _c =25°C	40	W
絶縁耐圧 Dielectric Strength	V _{dis}	一括端子・ケース間, AC 1 分間印加 Terminal to case AC 1 minute	2	kV
締め付けトルク Mounting Torque	TOR	(推奨値 : 3kg·cm) (Recommended torque : 3kg·cm)	5	kg·cm

■電氣的・熱的特性 Electrical Characteristics (T_c=25°C)

コレクタ・エミッタ電圧 Collector to Emitter Sustaining Voltage	V _{CE0(sus)}	I _c =0.2A	MIN 800	V
コレクタ遮断電流 Collector Cutoff Current	I _{CB0}	定格電圧において At rated voltage	MAX 0.1	mA
	I _{CE0}		MAX 0.2	
エミッタ遮断電流 Emitter Cutoff Current	I _{EB0}	定格電圧において At rated voltage	MAX 1	mA
直流電流増幅率 DC Current Gain	h _{FE}	V _{CE} =2V, I _c =3A	MIN 7	
	h _{FEL}	V _{CE} =2V, I _c =1mA	MIN 5	
コレクタ・エミッタ飽和電圧 Collector to Emitter Saturation Voltage	V _{CE(sat)}	I _c =3A, I _b =0.6A	MAX 1.5	V
ベース・エミッタ飽和電圧 Base to Emitter Saturation Voltage	V _{BE(sat)}		MAX 2.5	V
熱抵抗 Thermal Resistance	θ _{jc}	接合部・ケース間 Junction to case	MAX 3.1	°C/W
トランジション周波数 Transition Frequency	f _T	V _{CE} =10V, I _c =0.6A	TYP 7	MHz
ターンオン時間 Turn on Time	ton	V _{CC} =255V, I _c =3A I _{B1} =I _{B2} =0.6A R _L =85Ω, V _{BB2} =4V	MAX 0.5	μs
蓄積時間 Storage Time	ts		MAX 3.0	
下降時間 Fall Time	tf		MAX 0.5	