

## 2SC4463

### Silicon NPN Epitaxial UHF Frequency Converter

**Table 1 Absolute Maximum Ratings**  
( $T_a = 25^\circ\text{C}$ )

Item	Symbol	Rating	Unit
Collector to base voltage	$V_{\text{CBO}}$	30	V
Collector to emitter voltage	$V_{\text{CEO}}$	20	V
Emitter to base voltage	$V_{\text{EBO}}$	3	V
Collector current	$I_{\text{C}}$	50	mA
Collector power dissipation	$P_{\text{C}}$	100	mW
Junction temperature	$T_{\text{j}}$	150	$^\circ\text{C}$
Storage temperature	$T_{\text{stg}}$	-55 to +150	$^\circ\text{C}$

CMPAK

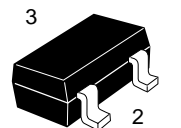

1. Emitter
2. Base
3. Collector

**Table 2 Electrical Characteristics** ( $T_a = 25^\circ\text{C}$ )

Item	Symbol	Min	Typ	Max	Unit	Test condition
Collector to base breakdown voltage	$V_{(\text{BR})\text{CBO}}$	30	—	—	V	$I_{\text{C}} = 10 \mu\text{A}$ , $I_{\text{E}} = 0$
Collector to emitter breakdown voltage	$V_{(\text{BR})\text{CEO}}$	20	—	—	V	$I_{\text{C}} = 1 \text{ mA}$ , $R_{\text{BE}} = \infty$
Emitter to base breakdown voltage	$V_{(\text{BR})\text{EBO}}$	3	—	—	V	$I_{\text{E}} = 10 \mu\text{A}$ , $I_{\text{C}} = 0$
Collector cutoff current	$I_{\text{CBO}}$	—	—	0.5	$\mu\text{A}$	$V_{\text{CB}} = 10 \text{ V}$ , $I_{\text{E}} = 0$
Collector to emitter saturation voltage	$V_{\text{CE}(\text{sat})}$	—	—	1.0	V	$I_{\text{C}} = 20 \text{ mA}$ , $I_{\text{B}} = 4 \text{ mA}$
DC current transfer ratio	$h_{\text{FE}}$	60	120	—	—	$V_{\text{CE}} = 10 \text{ V}$ , $I_{\text{C}} = 10 \text{ mA}$
Gain bandwidth product	$f_{\text{T}}$	600	1000	—	MHz	$V_{\text{CE}} = 10 \text{ V}$ , $I_{\text{C}} = 10 \text{ mA}$
Reverse transfer capacitance	$C_{\text{re}}$	—	0.35	0.65	pF	$V_{\text{CB}} = 10 \text{ V}$ , $I_{\text{E}} = 0$ , emitter common, $f = 1 \text{ MHz}$
Conversion gain	CG	—	21	—	dB	$V_{\text{CC}} = 12 \text{ V}$ , $I_{\text{C}} = 2 \text{ mA}$ , $f = 200 \text{ MHz}$ ,
Noise figure	NF	—	4.0	—	dB	$f_{\text{OSC}} = 230 \text{ MHz}$ (0 dBm), $f_{\text{out}} = 30 \text{ MHz}$

- Marking is "HC".

Maximum collector dissipation curve

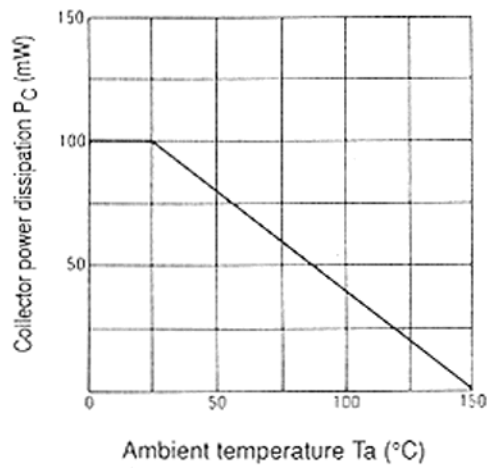

DC current transfer ratio vs. collector current

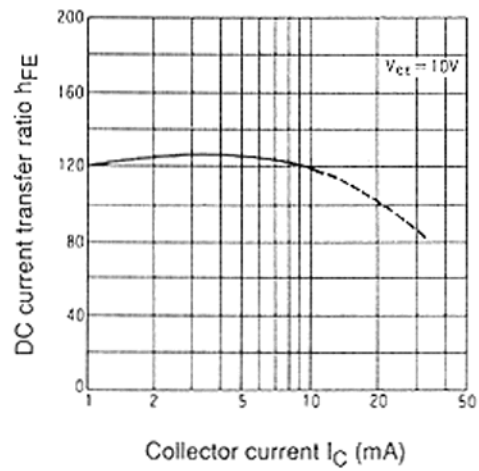

Gain bandwidth product vs. collector current

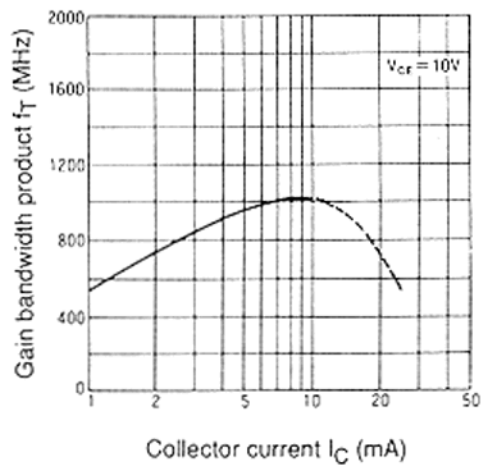

Reverse transfer capacitance vs. collector to base voltage

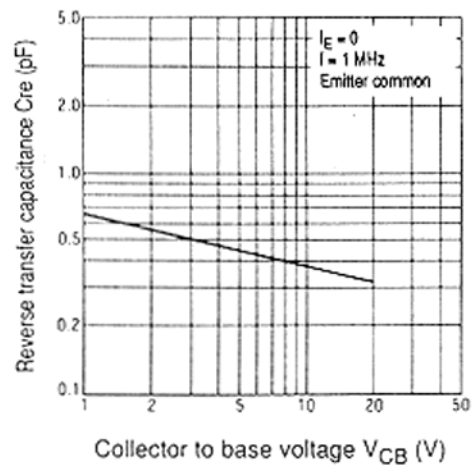

## 2SC4463

Conversion gain vs. collector current

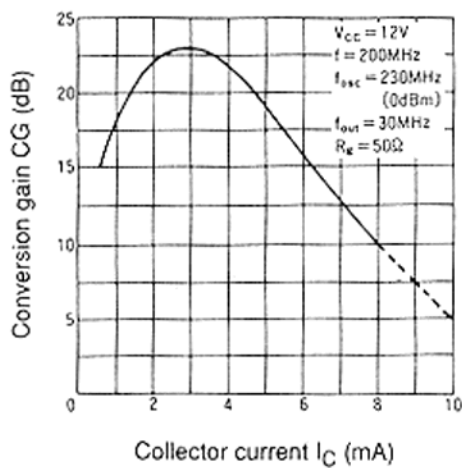

Noise figure vs. collector current

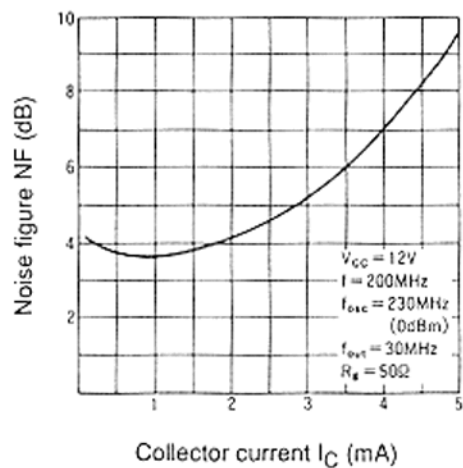

Conversion gain, noise figure vs. oscillating injection voltage

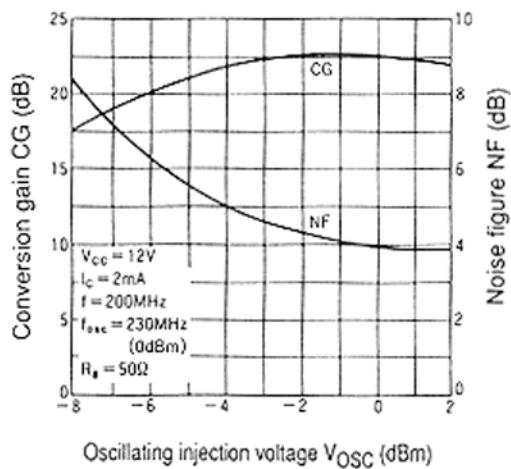

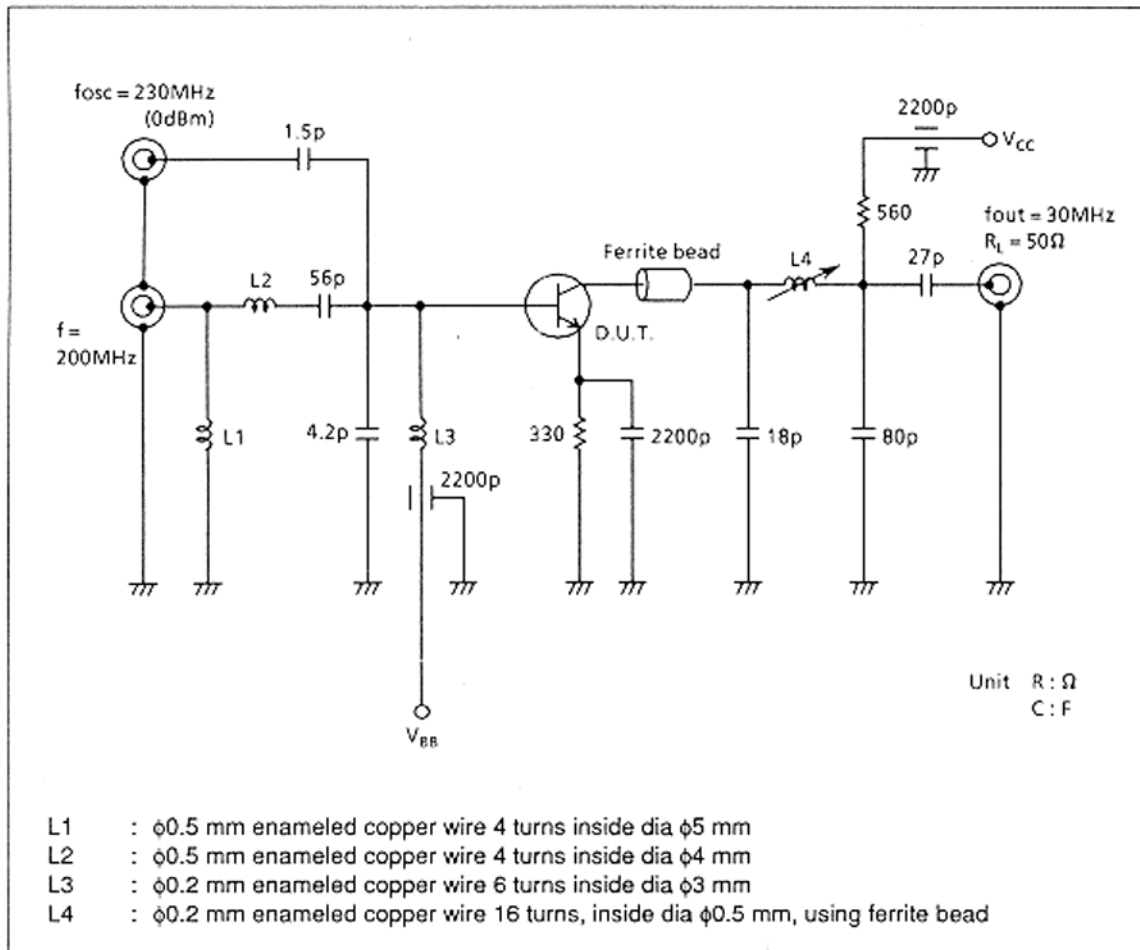

Conversion Gain, Noise Figure Test Circuit