

## 2SC4904

### Silicon NPN Bipolar Transistor

#### Application

VHF & UHF wide band amplifire

#### Features

- High gain bandwidth product  
 $f_T = 5.8 \text{ GHz typ}$
- High gain, low noise figure  
PG = 12.0 dB typ,  
NF = 1.6 dB typ at  $f = 900 \text{ MHz}$

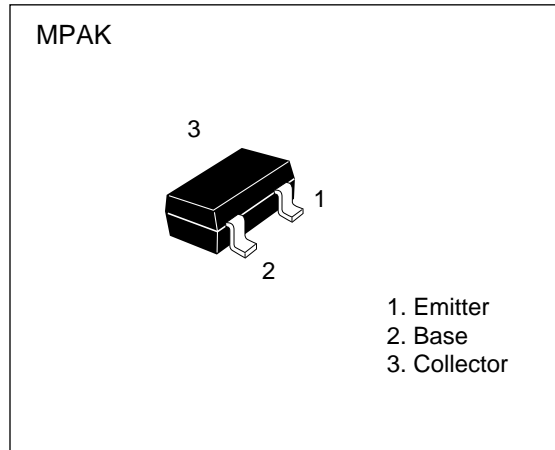

**Table 1 Absolute Maximum Ratings** ( $T_a = 25^\circ\text{C}$ )

Item	Symbol	Ratings	Unit
Collector to base voltage	$V_{CBO}$	20	V
Collector to emitter voltage	$V_{CEO}$	12	V
Emitter to base voltage	$V_{EBO}$	2	V
Collector current	$I_C$	50	mA
Collector power dissipation	$P_C$	150	mW
Junction temperature	$T_j$	150	$^\circ\text{C}$
Storage temperature	$T_{stg}$	-55 to +150	$^\circ\text{C}$

## 2SC4904

**Table 2 Electrical Characteristics (Ta = 25°C)**

Item	Symbol	Min	Typ	Max	Unit	Test conditions
Collector to base breakdown voltage	$V_{(BR)CBO}$	20	—	—	V	$I_C = 10 \mu A, I_E = 0$
Collector cutoff current	$I_{CBO}$	—	—	10	$\mu A$	$V_{CB} = 15 V, I_E = 0$
	$I_{CEO}$	—	—	1	mA	$V_{CE} = 12 V, R_{BE} = \infty$
Emitter cutoff current	$I_{EBO}$	—	—	10	$\mu A$	$V_{EB} = 2 V, I_C = 0$
DC current transfer ratio	$h_{FE}$	50	120	250		$V_{CE} = 5 V, I_C = 20 mA$
Output capacitance	$C_{ob}$	—	0.8	1.2	pF	$V_{CB} = 5 V, I_E = 0, f = 1 MHz$
Gain bandwidth product	$f_T$	4.0	5.8	—	GHz	$V_{CE} = 5 V, I_C = 20 mA$
Power gain	PG	9.5	12.0	—	dB	$V_{CE} = 5 V, I_C = 20 mA, f = 900 MHz$
Noise figure	NF	—	1.6	3.0	dB	$V_{CE} = 5 V, I_C = 5 mA, f = 900 MHz$

Marking for 2SC4904 is "YM-".

Maximum collector power dissipation curve

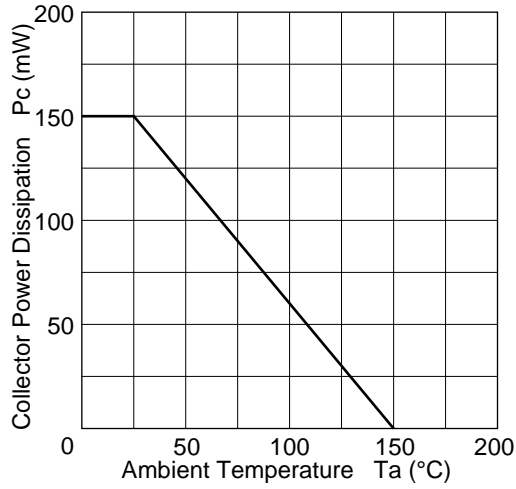

DC current transfer ratio vs. collector current

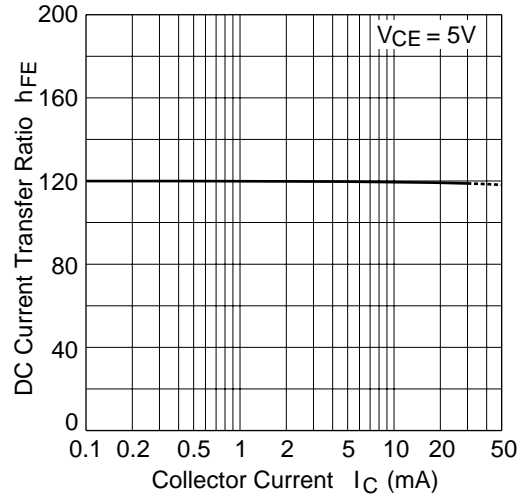

Gain bandwidth product vs. collector current

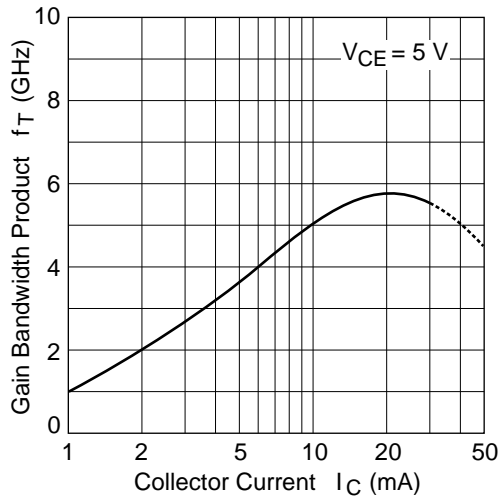

Collector output capacitance vs. collector to base voltage

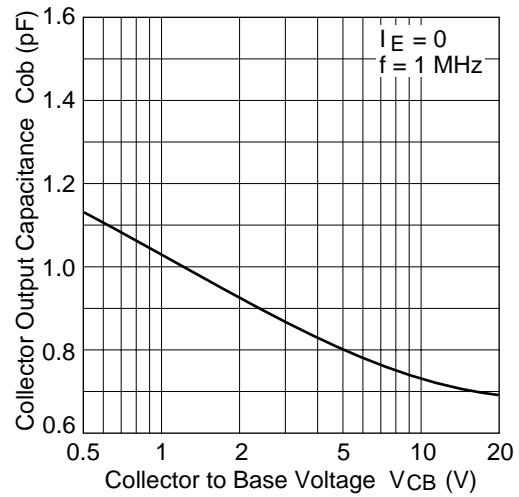

2SC4904

Power gain vs. collector current

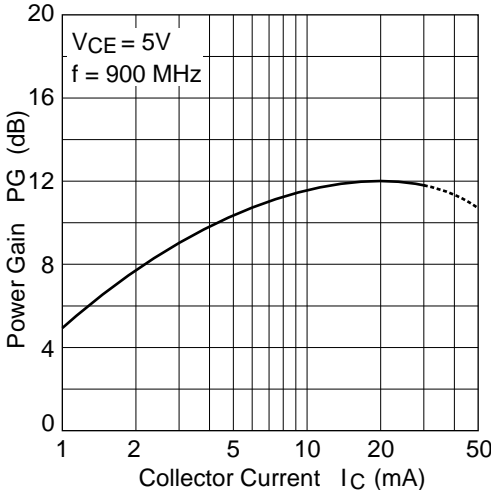

Noise figure vs. collector current

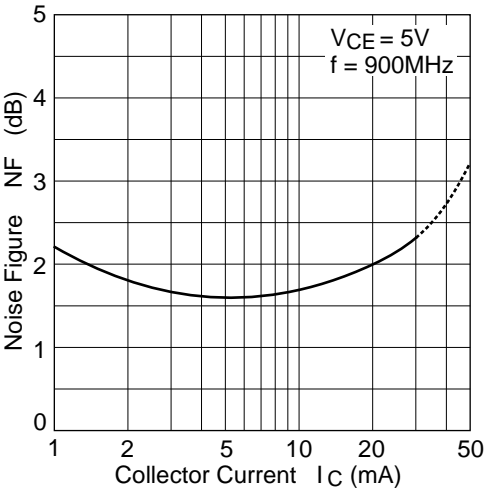

S21 parameter vs. collector current

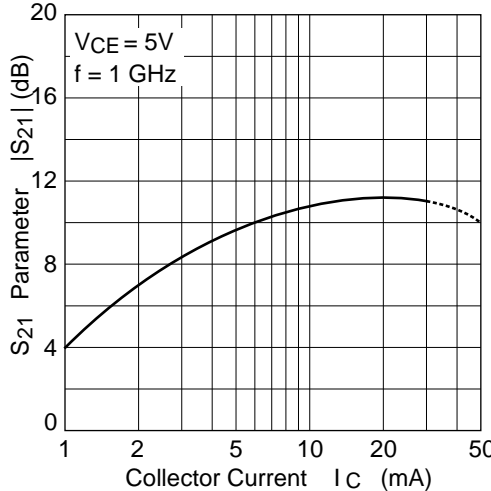

S11 parameter vs. frequency

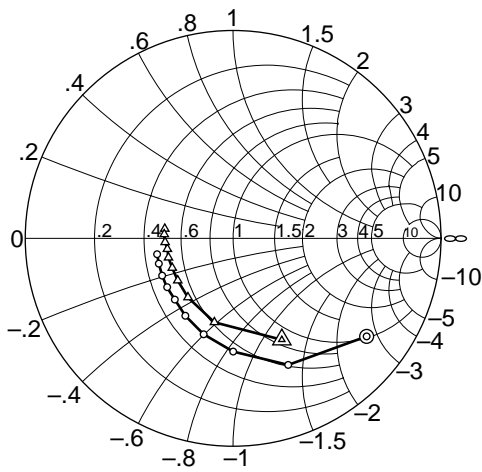

Condition:  $V_{CE} = 5\text{ V}$ ,  $Z_o = 50\ \Omega$   
 100 MHz to 1000 MHz (100 MHz step)  
 ○ — ○ ( $I_C = 5\text{ mA}$ )  
 △ — △ ( $I_C = 20\text{ mA}$ )

S21 parameter vs. frequency

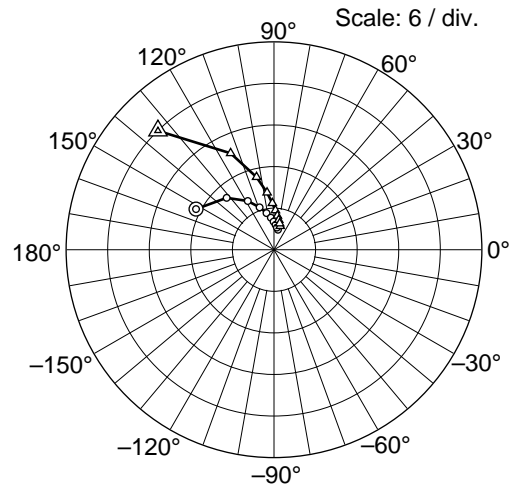

Condition:  $V_{CE} = 5\text{ V}$ ,  $Z_o = 50\ \Omega$   
 100 MHz to 1000 MHz (100 MHz step)  
 ○ — ○ ( $I_C = 5\text{ mA}$ )  
 △ — △ ( $I_C = 20\text{ mA}$ )

S12 parameter vs. frequency

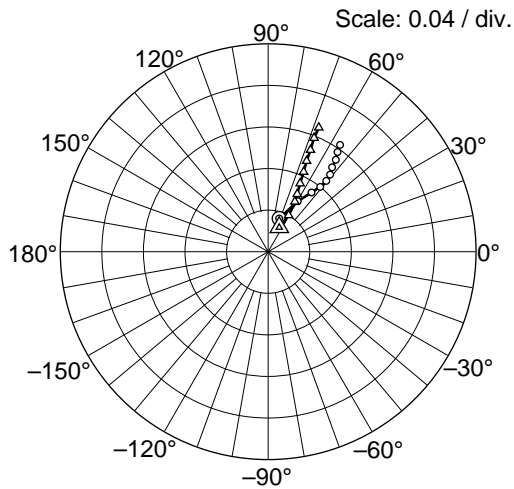

Condition:  $V_{CE} = 5\text{ V}$ ,  $Z_o = 50\ \Omega$   
 100 MHz to 1000 MHz (100 MHz step)  
 ○ — ○ ( $I_C = 5\text{ mA}$ )  
 △ — △ ( $I_C = 20\text{ mA}$ )

S22 parameter vs. frequency

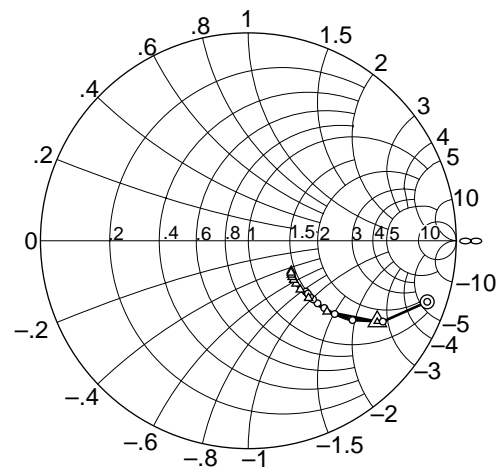

Condition:  $V_{CE} = 5\text{ V}$ ,  $Z_o = 50\ \Omega$   
 100 MHz to 1000 MHz (100 MHz step)  
 ○ — ○ ( $I_C = 5\text{ mA}$ )  
 △ — △ ( $I_C = 20\text{ mA}$ )

## 2SC4904

**Table 3 S Parameter** ( $V_{CE} = 5\text{ V}$ ,  $I_C = 5\text{ mA}$ ,  $Z_O = 50\ \Omega$ , Emitter common)

f (MHz)	S11		S21		S12		S22	
	MAG	ANG	MAG	ANG	MAG	ANG	MAG	ANG
100	0.797	-36.3	12.71	152.4	0.0337	71.8	0.909	-18.8
200	0.664	-66.5	10.16	132.3	0.0565	59.7	0.755	-31.0
300	0.545	-90.0	8.01	118.2	0.0708	53.9	0.630	-37.3
400	0.483	-107.1	6.49	108.7	0.0801	51.3	0.545	-40.3
500	0.438	-121.7	5.43	101.5	0.0883	50.7	0.488	-41.5
600	0.407	-133.6	4.67	95.6	0.0953	51.3	0.449	-42.1
700	0.395	-143.5	4.09	90.8	0.102	52.9	0.420	-42.1
800	0.386	-152.3	3.63	86.4	0.110	53.7	0.401	-42.2
900	0.378	-161.2	3.26	82.6	0.117	55.2	0.383	-41.6
1000	0.374	-168.2	2.97	78.9	0.124	56.1	0.370	-41.4

**Table 4 S Parameter** ( $V_{CE} = 5\text{ V}$ ,  $I_C = 20\text{ mA}$ ,  $Z_O = 50\ \Omega$ , Emitter common)

f (MHz)	S11		S21		S12		S22	
	MAG	ANG	MAG	ANG	MAG	ANG	MAG	ANG
100	0.541	-64.4	24.01	134.3	0.0257	65.7	0.732	-32.1
200	0.414	-102.6	15.27	114.2	0.0402	60.6	0.510	-42.0
300	0.358	-127.4	10.78	103.5	0.0513	61.9	0.400	-43.6
400	0.335	-142.7	8.31	96.9	0.0621	63.2	0.343	-43.3
500	0.326	-154.1	6.73	92.0	0.0727	64.9	0.309	-42.0
600	0.325	-163.4	5.69	87.9	0.0840	66.0	0.288	-40.9
700	0.321	-170.7	4.93	84.3	0.0948	67.0	0.274	-39.7
800	0.328	-176.7	4.35	80.9	0.106	67.4	0.264	-38.3
900	0.332	176.7	3.88	77.8	0.118	68.0	0.257	-36.8
1000	0.332	172.1	3.53	75.2	0.129	67.8	0.252	-35.0