

# SHINDENGEN

## Switching Power Transistor

# 2SC4940

## 4A NPN

### OUTLINE DIMENSIONS

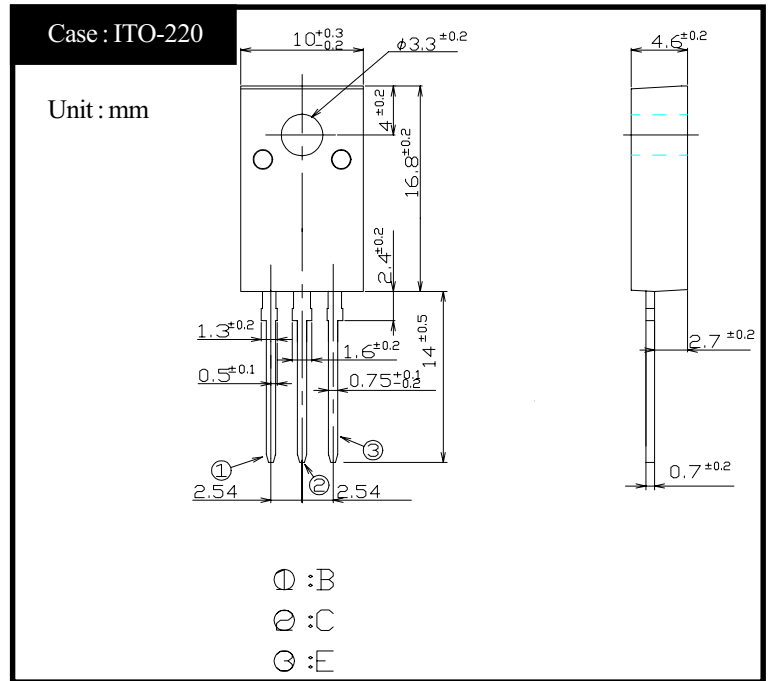

### RATINGS

#### ● Absolute Maximum Ratings

Item	Symbol	Conditions	Ratings	Unit
Storage Temperature	$T_{stg}$		-55~150	°C
Junction Temperature	$T_j$		150	°C
Collector to Base Voltage	$V_{CBO}$		1200	V
Collector to Emitter Voltage	$V_{CEO}$		550	V
Emitter to Base Voltage	$V_{EBO}$		7	V
Collector Current DC	$I_C$		4	A
Collector Current Peak	$I_{CP}$		8	
Base Current DC	$I_B$		2	A
Base Current Peak	$I_{BP}$		4	
Total Transistor Dissipation	$P_T$		30	W
Dielectric Strength	$V_{dis}$	Terminals to case, AC 1 minute	2	kV
Mounting Torque	TOR	(Recommended torque)	0.5(0.3)	N·m

#### ● Electrical Characteristics ( $T_c=25^\circ\text{C}$ )

Item	Symbol	Conditions	Ratings	Unit
Collector to Emitter Sustaining Voltage	$V_{CEO(sus)}$	$I_C = 0.1A$	Min 550	V
Collector Cutoff Current	$I_{CBO}$	rated $V_{CBO}$	Max 0.1	mA
	$I_{CEO}$	rated $V_{CEO}$	Max 0.1	
Emitter Cutoff Current	$I_{EBO}$	rated $V_{EBO}$	Max 0.1	mA
DC Current Gain	$h_{FE}$	$V_{CE} = 5V, I_C = 2A$	Min 10	
	$h_{FEL}$	$V_{CE} = 5V, I_C = 1mA$	Min 10	
Collector to Emitter Saturation Voltage	$V_{CE(sat)}$	$I_C = 2A$	Max 1.0	V
Base to Emitter Saturation Voltage	$V_{BE(sat)}$	$I_B = 0.4A$	Max 1.5	
Thermal Resistance	$\theta_{jc}$	Junction to case	Max 4.16	°C/W
Transition Frequency	$f_T$	$V_{CE} = 10V, I_C = 0.4A$	TYP 10	MHz
Turn on Time	$t_{on}$	$I_C = 2A$	Max 0.8	$\mu s$
Storage Time	$t_s$	$I_{B1} = 0.4A, I_{B2} = 0.8A$	Max 3.0	
Fall Time	$t_f$	$R_L = 75\Omega, V_{BB2} = 4V$	Max 0.3	

# 2SC4940

$h_{FE} - I_C$

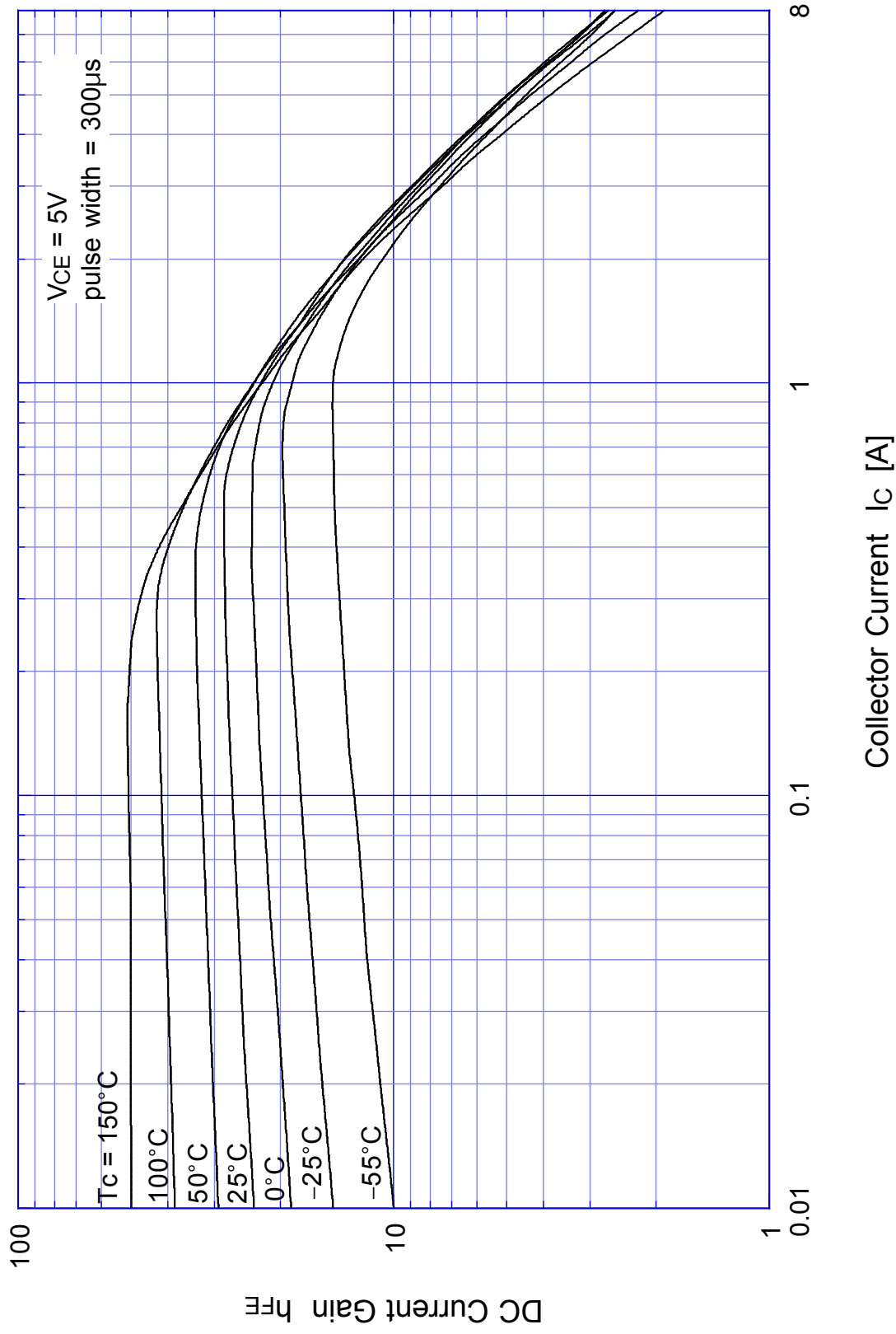

# 2SC4940 Saturation Voltage

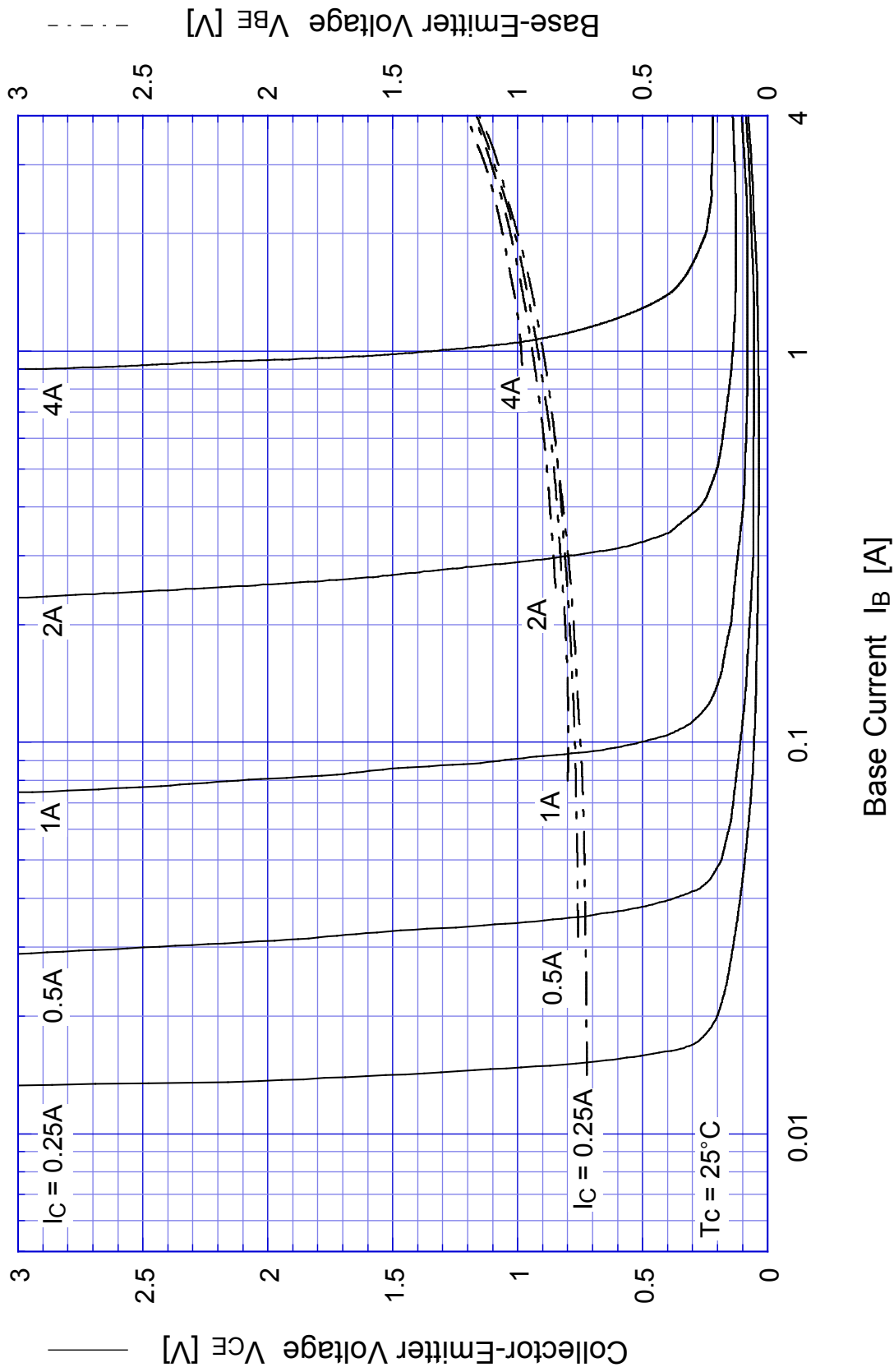

# 2SC4940

## Switching Time - $I_C$

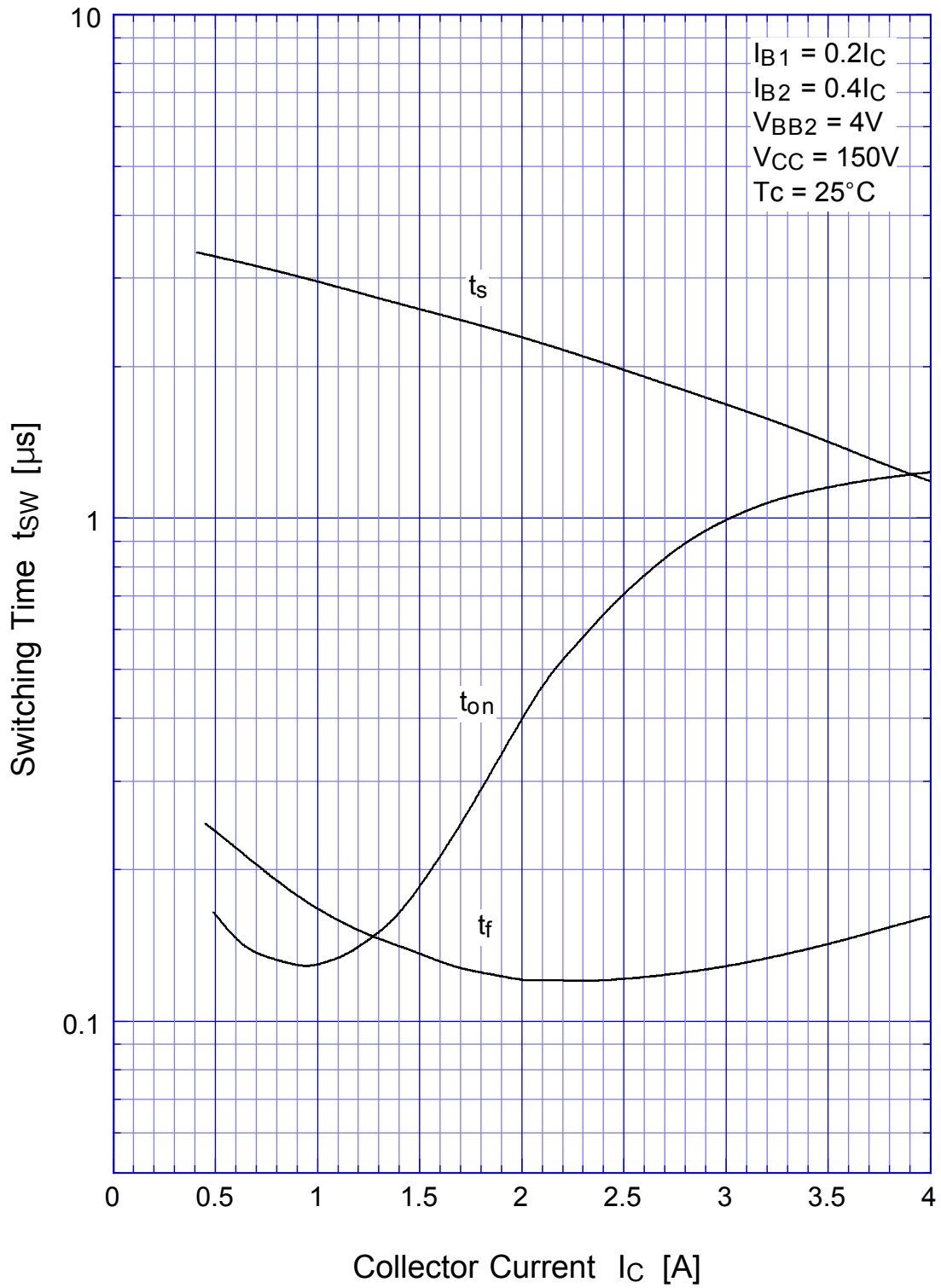

# 2SC4940

## Switching Time - Tc

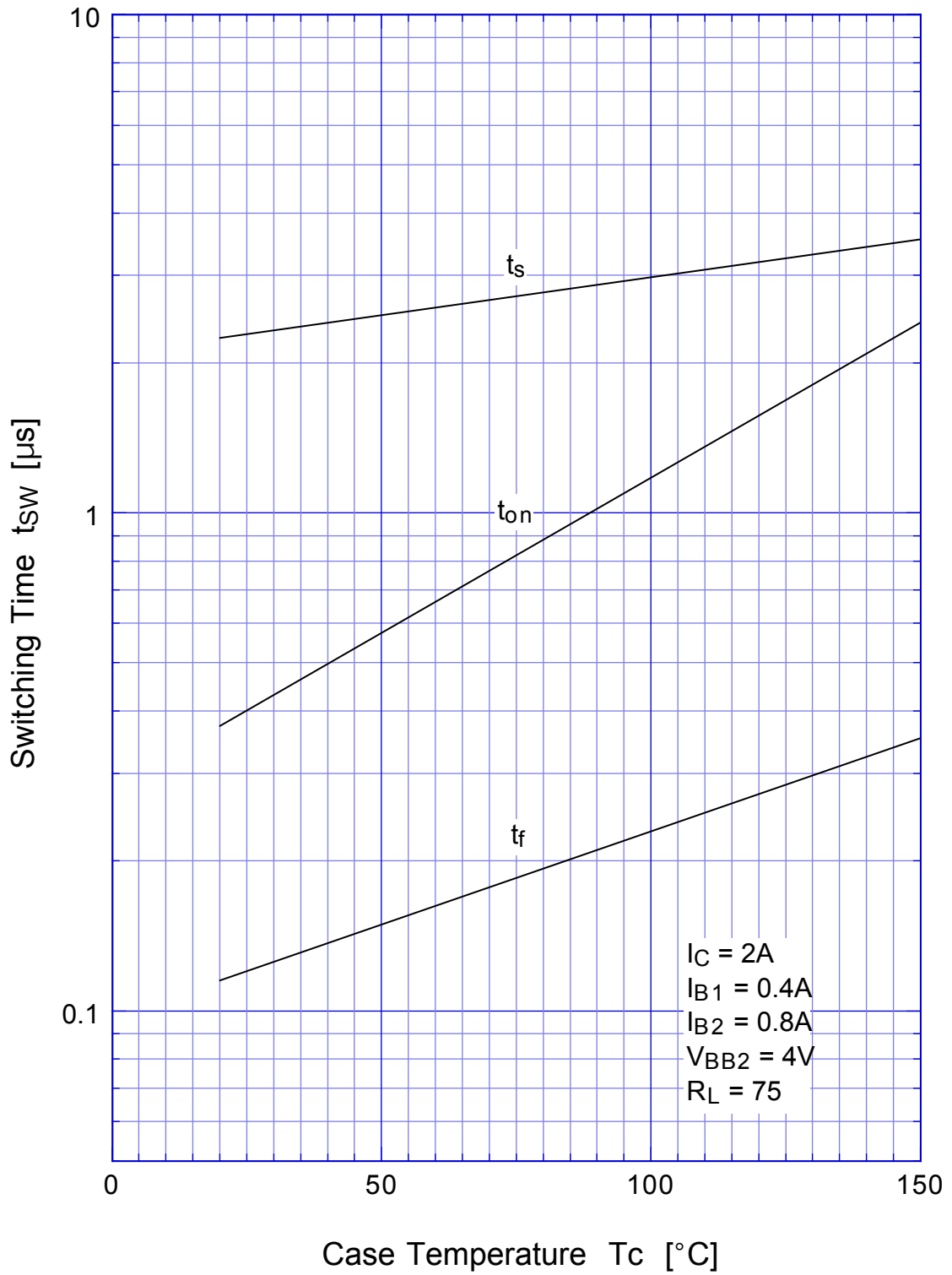

# 2SC4940

# Forward Bias SOA

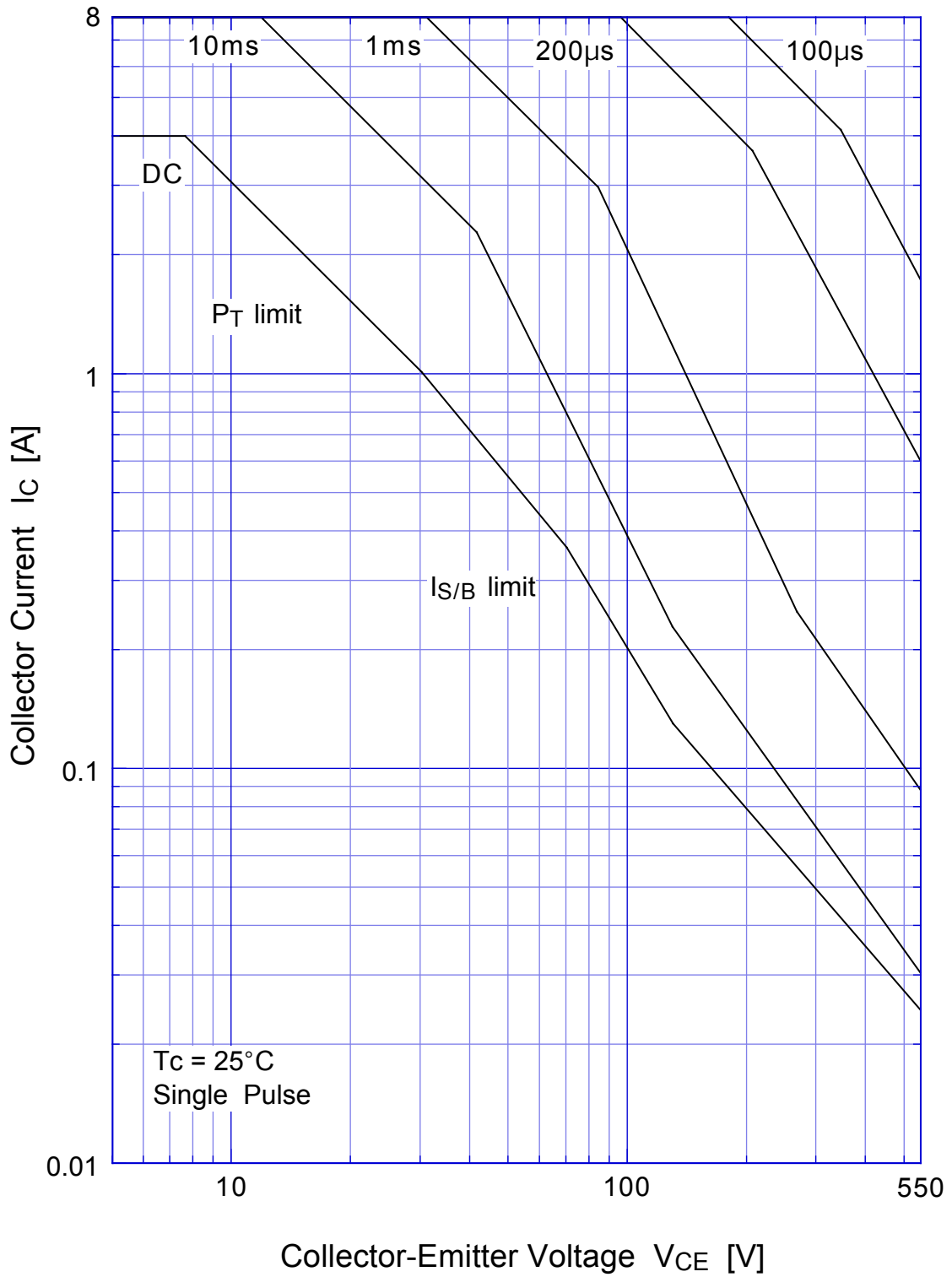

## 2SC4940 Collector Current Derating

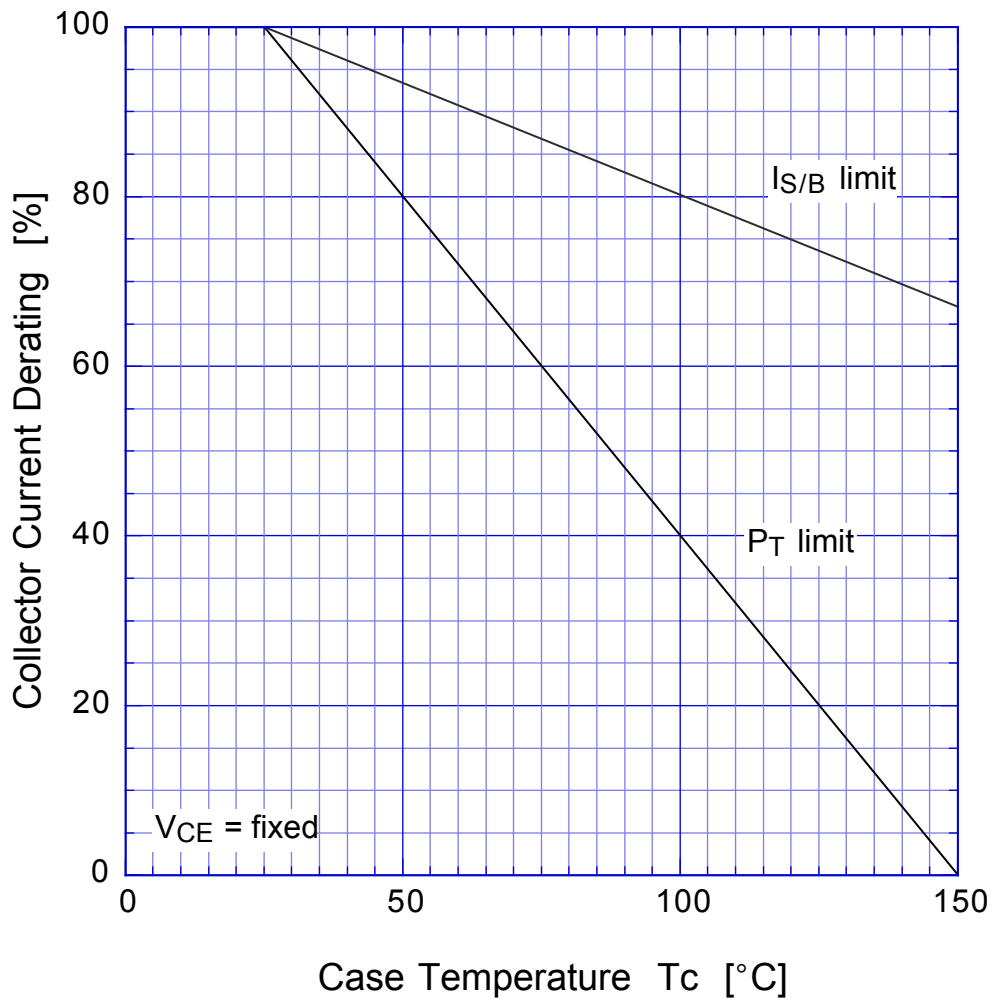

2SC4940

Reverse Bias SOA

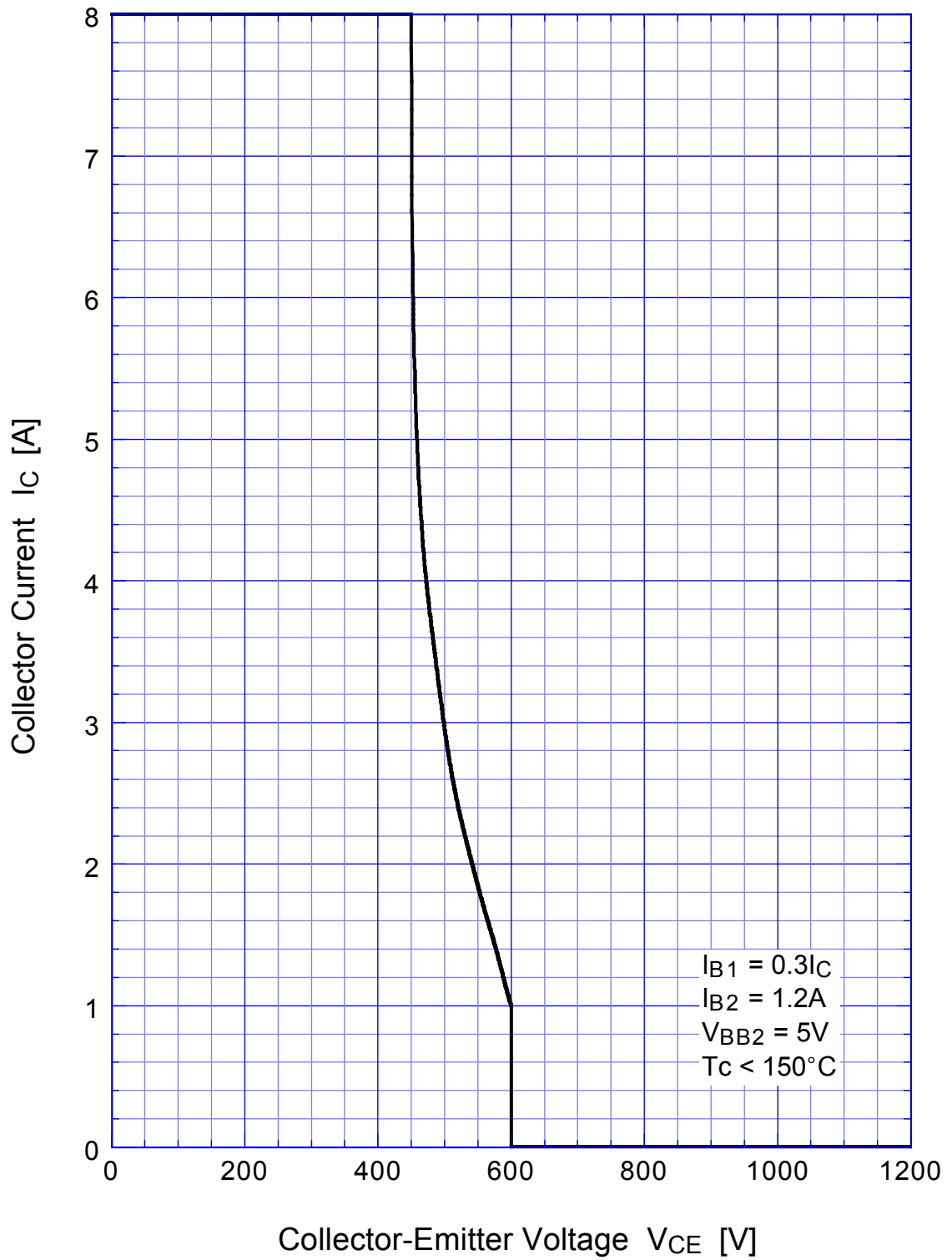

## 2SC4940 Transient Thermal Impedance

