

2SC5139

Silicon NPN Epitaxial Transistor

Application

VHF & UHF wide band amplifier

Features

- High gain bandwidth product
 $f_T = 11 \text{ GHz typ.}$
- High gain, low noise figure
 $PG = 15 \text{ dB typ.},$
 $NF = 1.1 \text{ dB typ. at } f = 900 \text{ MHz}$

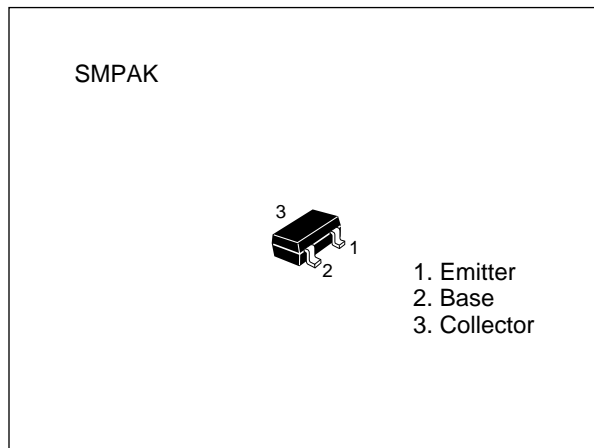

Table 1 Absolute Maximum Ratings ($T_a = 25^\circ\text{C}$)

Item	Symbol	Ratings	Unit
Collector to base voltage	V_{CBO}	15	V
Collector to emitter voltage	V_{CEO}	8	V
Emitter to base voltage	V_{EBO}	1.5	V
Collector current	I_C	50	mA
Collector power dissipation	P_C	80	mW
Junction temperature	T_j	150	$^\circ\text{C}$
Storage temperature	T_{stg}	-55 to +150	$^\circ\text{C}$

Note: Marking is "YZ-"

Attention: This device is very sensitive to electro static discharge.

It is recommended to adopt appropriate cautions when handling this transistor.

2SC5139

Table 2 Electrical Characteristics (Ta = 25°C)

Item	Symbol	Min.	Typ.	Max.	Unit	Test conditions
Collector to base breakdown voltage	$V_{(BR)CBO}$	15	—	—	V	$I_C = 10 \mu A$ $I_E = 0$
Collector cutoff current	I_{CBO}	—	—	1	μA	$V_{CB} = 12 V$, $I_E = 0$
	I_{CEO}	—	—	1	mA	$V_{CE} = 8 V$, $R_{BE} = \infty$
Emitter cutoff current	I_{EBO}	—	—	10	μA	$V_{EB} = 1.5 V$, $I_C = 0$
DC current transfer ratio	h_{FE}	50	120	250		$V_{CE} = 4 V$, $I_C = 20 mA$
Output capacitance	Cob	—	0.65	1.15	pF	$V_{CB} = 5 V$, $I_E = 0$, $f = 1 MHz$
Gain bandwidth product	f_T	8	11	—	GHz	$V_{CE} = 4 V$, $I_C = 20 mA$
Power gain	PG	11.5	15	—	dB	$V_{CE} = 4 V$, $I_C = 20 mA$, $f = 900 MHz$
Noise figure	NF	—	1.1	2.0	dB	$V_{CE} = 4 V$, $I_C = 5 mA$, $f = 900 MHz$

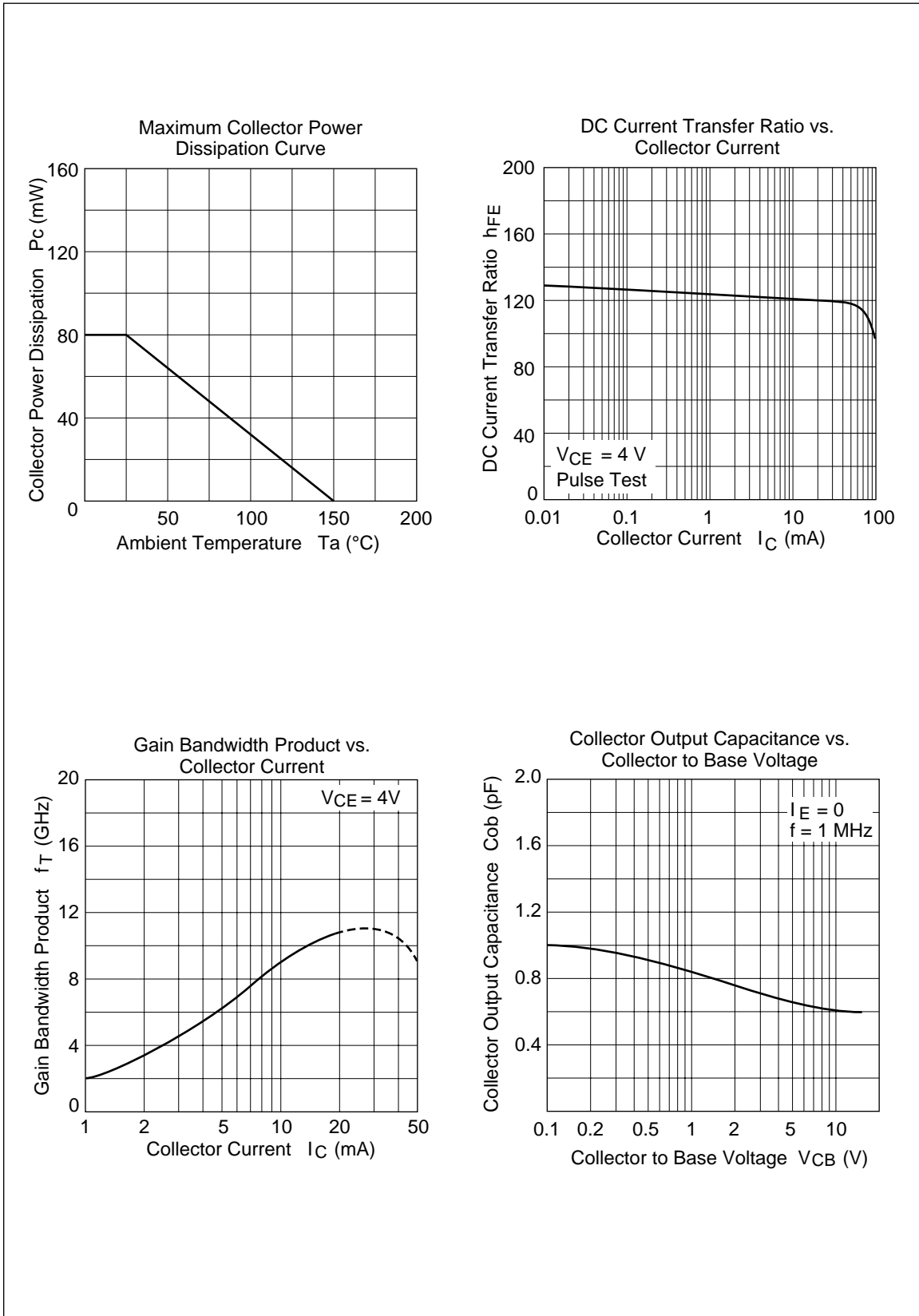

2SC5139

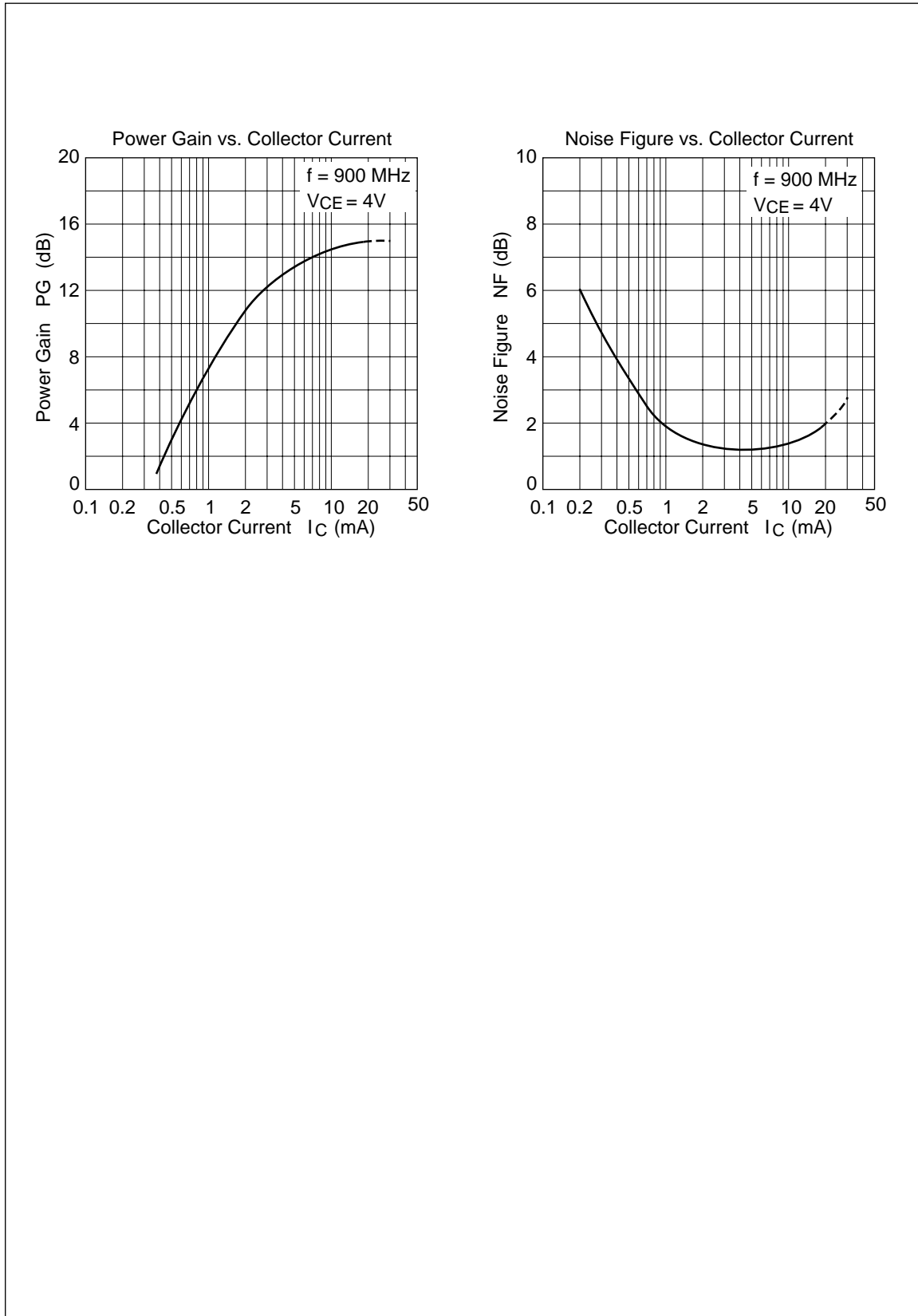

S11 Parameter vs. Frequency

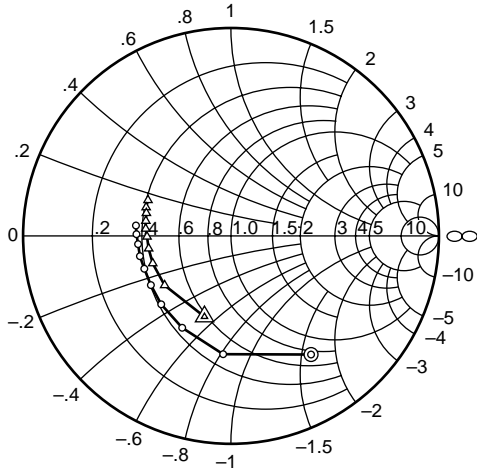

Condition: $V_{CE} = 4 \text{ V}$, $Z_o = 50 \Omega$
 200 to 2000 MHz (200 MHz step)
 ○ — ○ ($I_C = 5 \text{ mA}$)
 △ — △ ($I_C = 20 \text{ mA}$)

S21 Parameter vs. Frequency

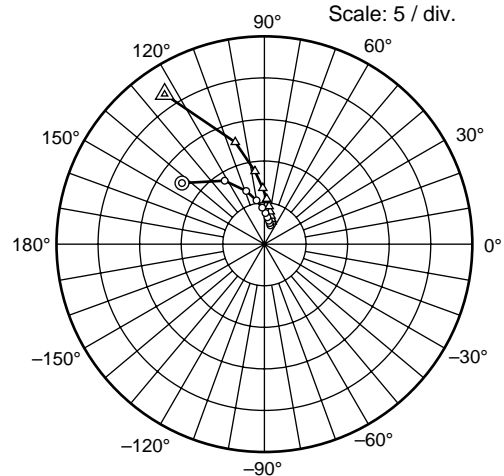

Condition: $V_{CE} = 4 \text{ V}$, $Z_o = 50 \Omega$
 200 to 2000 MHz (200 MHz step)
 ○ — ○ ($I_C = 5 \text{ mA}$)
 △ — △ ($I_C = 20 \text{ mA}$)

S12 Parameter vs. Frequency

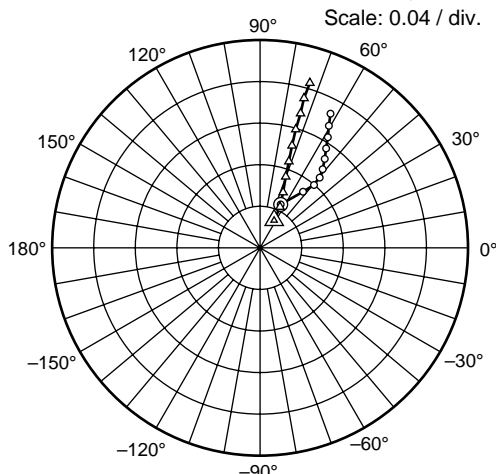

Condition: $V_{CE} = 4 \text{ V}$, $Z_o = 50 \Omega$
 200 to 2000 MHz (200 MHz step)
 ○ — ○ ($I_C = 5 \text{ mA}$)
 △ — △ ($I_C = 20 \text{ mA}$)

S22 Parameter vs. Frequency

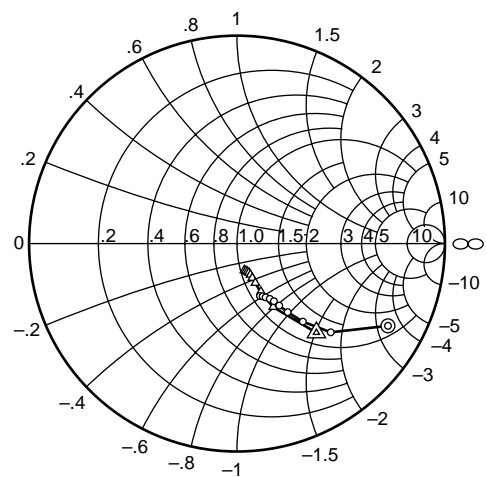

Condition: $V_{CE} = 4 \text{ V}$, $Z_o = 50 \Omega$
 200 to 2000 MHz (200 MHz step)
 ○ — ○ ($I_C = 5 \text{ mA}$)
 △ — △ ($I_C = 20 \text{ mA}$)

2SC5139

S11 Parameter vs. Frequency

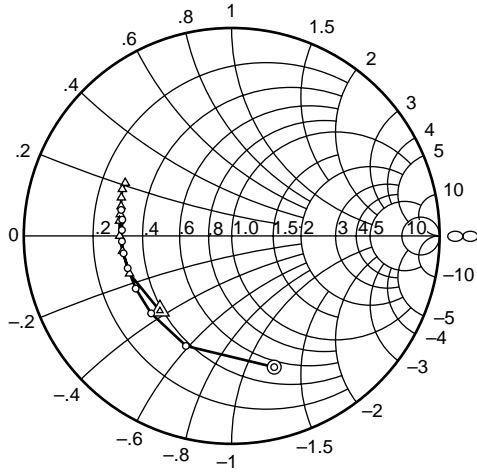

Condition: $V_{CE} = 1\text{ V}$, $Z_o = 50\ \Omega$
 200 to 2000 MHz (200 MHz step)
 ○ — ○ ($I_C = 5\text{ mA}$)
 △ — △ ($I_C = 20\text{ mA}$)

S21 Parameter vs. Frequency

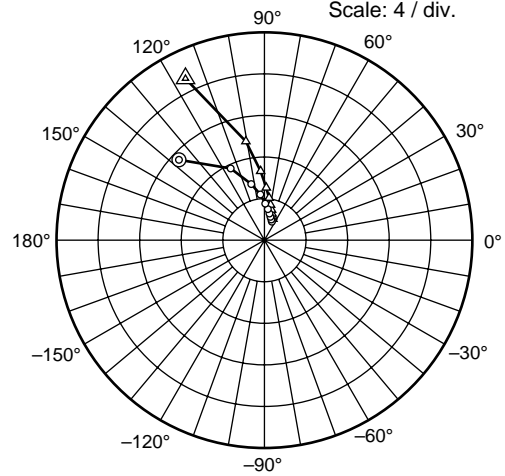

Condition: $V_{CE} = 1\text{ V}$, $Z_o = 50\ \Omega$
 200 to 2000 MHz (200 MHz step)
 ○ — ○ ($I_C = 5\text{ mA}$)
 △ — △ ($I_C = 20\text{ mA}$)

S12 Parameter vs. Frequency

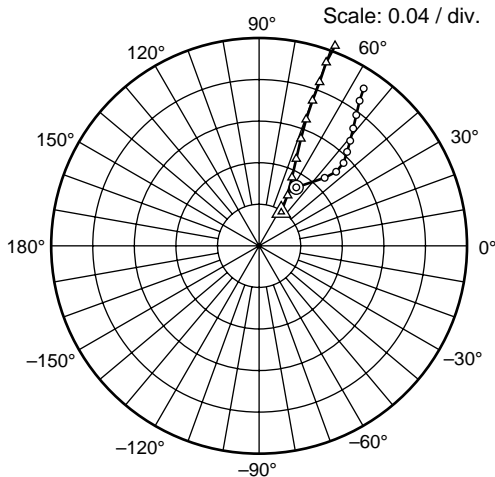

Condition: $V_{CE} = 1\text{ V}$, $Z_o = 50\ \Omega$
 200 to 2000 MHz (200 MHz step)
 ○ — ○ ($I_C = 5\text{ mA}$)
 △ — △ ($I_C = 20\text{ mA}$)

S22 Parameter vs. Frequency

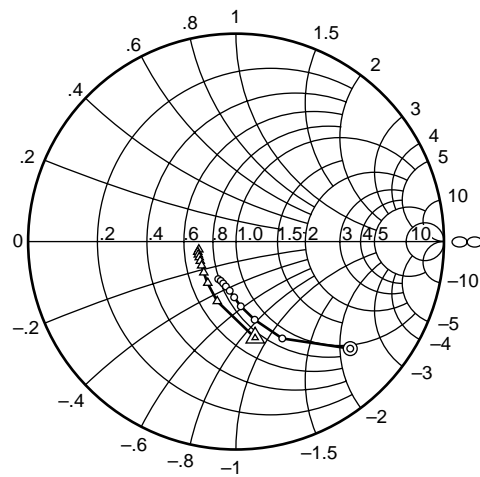

Condition: $V_{CE} = 1\text{ V}$, $Z_o = 50\ \Omega$
 200 to 2000 MHz (200 MHz step)
 ○ — ○ ($I_C = 5\text{ mA}$)
 △ — △ ($I_C = 20\text{ mA}$)

Package Dimensions

Unit : mm

