

## 2SC5218

### Silicon NPN Epitaxial Transistor

#### Application

VHF & UHF wide band amplifier

#### Features

- High gain bandwidth product  
 $f_T = 9 \text{ GHz typ.}$
- High gain, low noise figure  
 $PG = 13.0 \text{ dB typ.,}$   
 $NF = 1.2 \text{ dB typ. at } f = 900 \text{ MHz}$

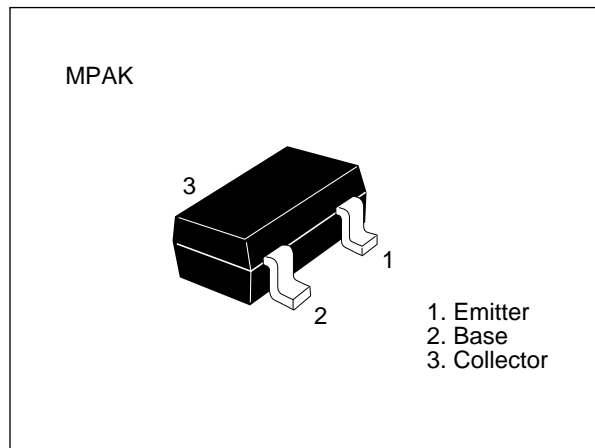

**Table 1 Absolute Maximum Ratings** ( $T_a = 25^\circ\text{C}$ )

Item	Symbol	Ratings	Unit
Collector to base voltage	$V_{CBO}$	15	V
Collector to emitter voltage	$V_{CEO}$	9	V
Emitter to base voltage	$V_{EBO}$	1.5	V
Collector current	$I_C$	50	mA
Collector power dissipation	$P_C$	150	mW
Junction temperature	$T_j$	150	$^\circ\text{C}$
Storage temperature	$T_{stg}$	-55 to +150	$^\circ\text{C}$

Note: Marking is "YK-"

Attention: This device is very sensitive to electro static discharge.

It is recommended to adopt appropriate cautions when handling this transistor.

## 2SC5218

**Table 2 Electrical Characteristics** (Ta = 25°C)

Item	Symbol	Min.	Typ.	Max.	Unit	Test conditions
Collector to base breakdown voltage	$V_{(BR)CBO}$	15	—	—	V	$I_C = 10 \mu A, I_E = 0$
Collector cutoff current	$I_{CBO}$	—	—	1	$\mu A$	$V_{CB} = 12 V, I_E = 0$
	$I_{CEO}$	—	—	1	mA	$V_{CE} = 9 V, R_{BE} = \infty$
Emitter cutoff current	$I_{EBO}$	—	—	10	$\mu A$	$V_{EB} = 1.5 V, I_C = 0$
DC current transfer ratio	$h_{FE}$	50	120	250		$V_{CE} = 5 V, I_C = 20 mA$
Output capacitance	Cob	—	0.8	1.4	pF	$V_{CB} = 5 V, I_E = 0, f = 1 MHz$
Gain bandwidth product	$f_T$	6.0	9.0	—	GHz	$V_{CE} = 5 V, I_C = 20 mA$
Power gain	PG	10	13	—	dB	$V_{CE} = 5 V, I_C = 20 mA, f = 900 MHz$
Noise figure	NF	—	1.2	2.5	dB	$V_{CE} = 5 V, I_C = 5 mA, f = 900 MHz$

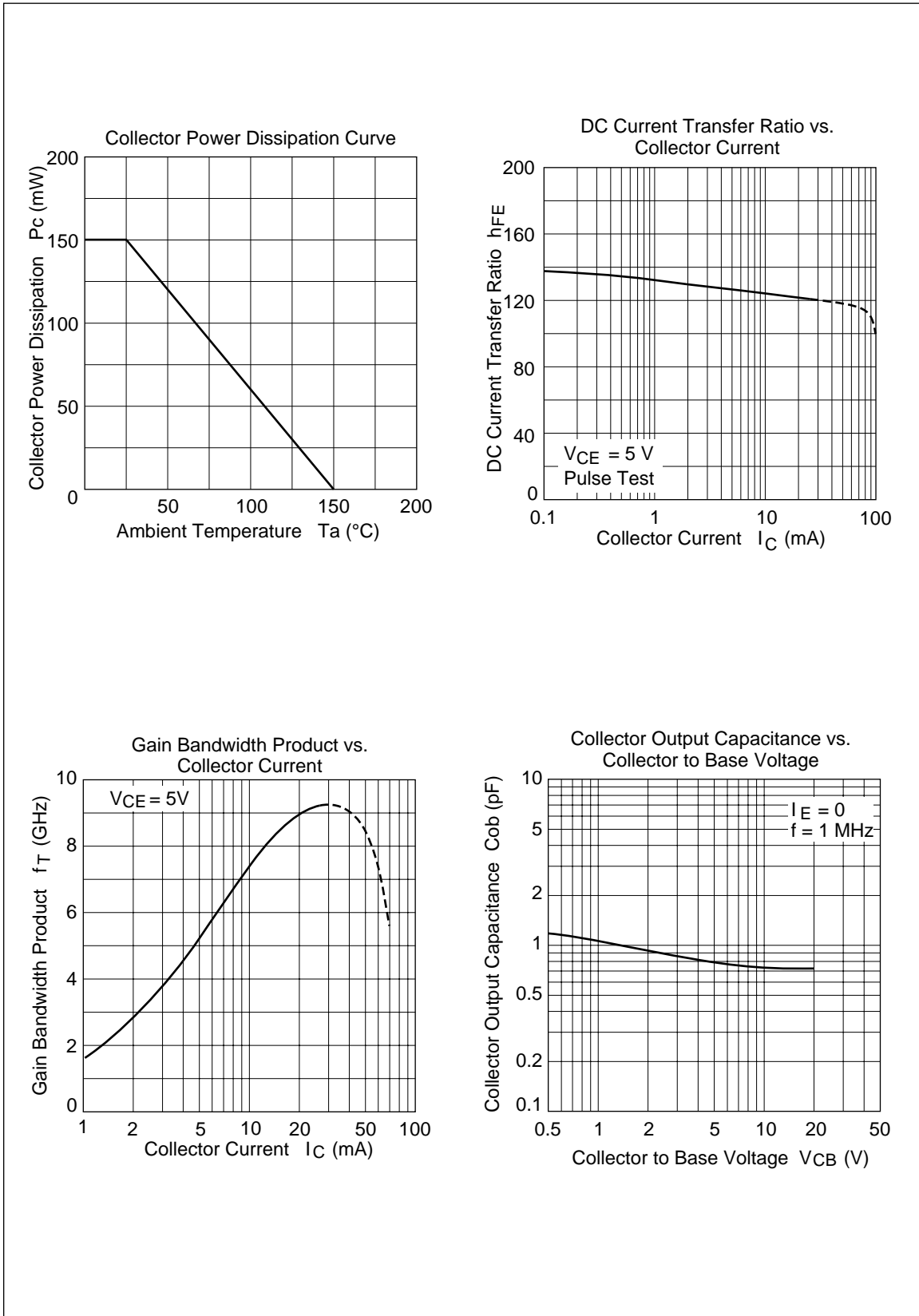

## 2SC5218

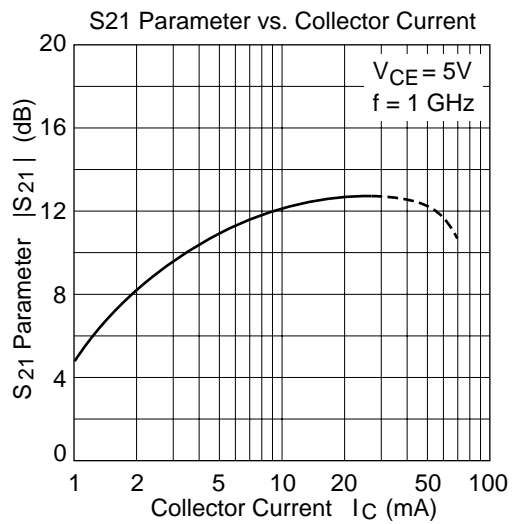
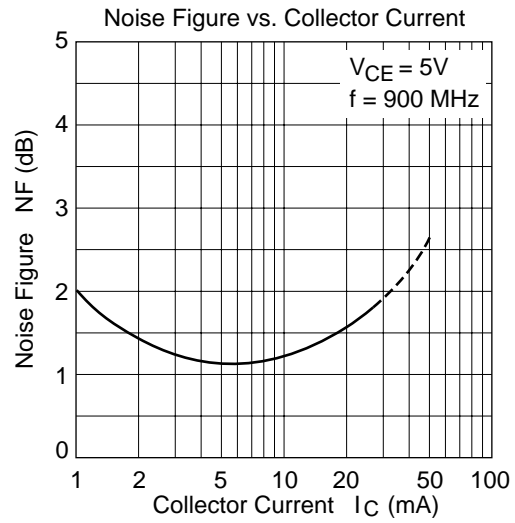
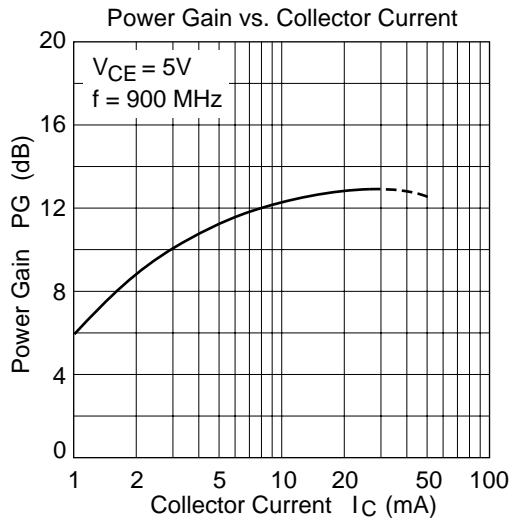

S11 Parameter vs. Frequency

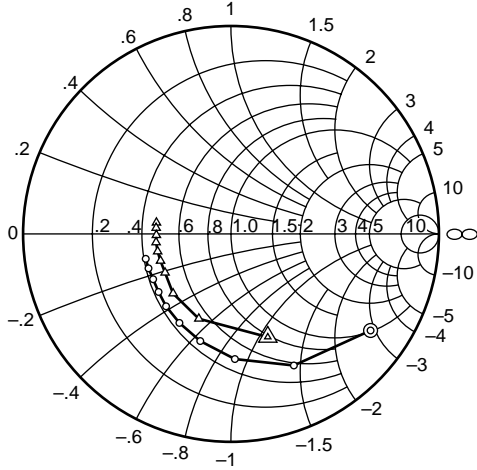

Condition:  $V_{CE} = 5\text{ V}$ ,  $Z_o = 50\ \Omega$   
 100 to 1000 MHz (100 MHz step)  
 ○ — ○ ( $I_C = 5\text{ mA}$ )  
 △ — △ ( $I_C = 20\text{ mA}$ )

S21 Parameter vs. Frequency

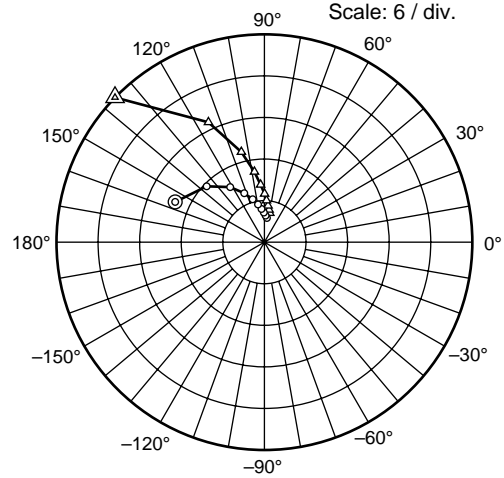

Condition:  $V_{CE} = 5\text{ V}$ ,  $Z_o = 50\ \Omega$   
 100 to 1000 MHz (100 MHz step)  
 ○ — ○ ( $I_C = 5\text{ mA}$ )  
 △ — △ ( $I_C = 20\text{ mA}$ )

S12 Parameter vs. Frequency

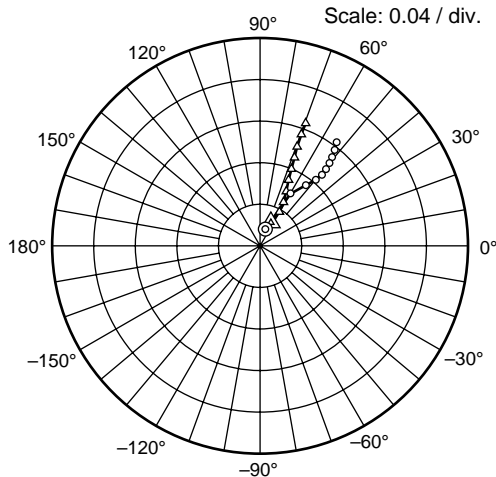

Condition:  $V_{CE} = 5\text{ V}$ ,  $Z_o = 50\ \Omega$   
 100 to 1000 MHz (100 MHz step)  
 ○ — ○ ( $I_C = 5\text{ mA}$ )  
 △ — △ ( $I_C = 20\text{ mA}$ )

S22 Parameter vs. Frequency

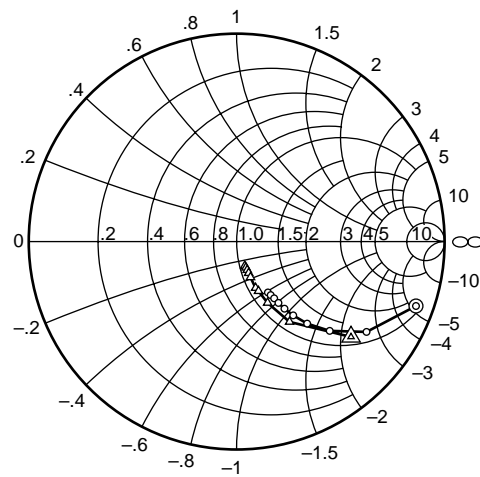

Condition:  $V_{CE} = 5\text{ V}$ ,  $Z_o = 50\ \Omega$   
 100 to 1000 MHz (100 MHz step)  
 ○ — ○ ( $I_C = 5\text{ mA}$ )  
 △ — △ ( $I_C = 20\text{ mA}$ )

## 2SC5218

**Table 3 S Parameter** ( $V_{CE} = 5\text{ V}$ ,  $I_C = 5\text{ mA}$ ,  $Z_O = 50\ \Omega$ )

f (MHz)	S11		S21		S12		S22	
	MAG	ANG	MAG	ANG	MAG	ANG	MAG	ANG
100	0.817	-34.7	14.1	156	0.034	72.3	0.916	-19.8
200	0.701	-64.5	11.6	136	0.058	59.8	0.761	-34.8
300	0.602	-88.3	9.32	122	0.073	52.9	0.620	-43.9
400	0.536	-106	7.61	112	0.083	49.8	0.520	-49.3
500	0.495	-120	6.40	105	0.091	48.9	0.447	-52.5
600	0.468	-132	5.50	99.5	0.097	49.3	0.396	-54.5
700	0.447	-141	4.80	94.9	0.104	50.0	0.357	-55.7
800	0.434	-150	4.27	90.9	0.110	50.9	0.327	-56.5
900	0.423	-157	3.83	87.2	0.117	52.1	0.305	-57.5
1000	0.428	-164	3.50	83.9	0.124	53.3	0.287	-58.4

**Table 4 S Parameter** ( $V_{CE} = 5\text{ V}$ ,  $I_C = 20\text{ mA}$ ,  $Z_O = 50\ \Omega$ )

f (MHz)	S11		S21		S12		S22	
	MAG	ANG	MAG	ANG	MAG	ANG	MAG	ANG
100	0.529	-70.4	29.9	136	0.025	64.9	0.716	-39.8
200	0.427	-111	19.0	115	0.038	60.3	0.462	-56.6
300	0.386	-134	13.4	104	0.048	61.8	0.330	-63.2
400	0.370	-150	10.2	98.0	0.058	64.3	0.260	-66.2
500	0.366	-159	8.28	93.7	0.069	66.6	0.214	-67.8
600	0.367	-167	6.96	89.7	0.080	67.8	0.184	-68.8
700	0.364	-174	6.01	87.0	0.091	68.7	0.162	-69.1
800	0.360	-179	5.28	84.2	0.102	69.5	0.146	-69.7
900	0.362	176	4.71	81.7	0.115	69.4	0.133	-70.4
1000	0.364	171	4.27	79.3	0.126	69.6	0.123	-71.5

### Package Dimensions

Unit : mm

