

## 2SC5247

### Silicon NPN Epitaxial Transistor

#### Application

VHF & UHF wide band amplifier

#### Features

- High gain bandwidth product  
 $f_T = 13.5$  GHz typ.
- High gain, low noise figure  
 $PG = 17$  dB typ.,  
 $NF = 1.2$  dB typ. at  $f = 900$  MHz

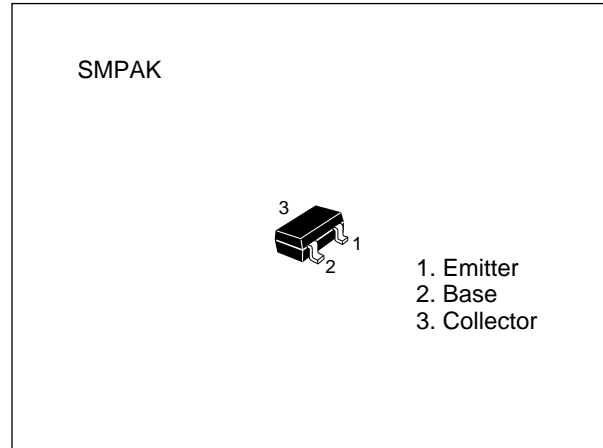

**Table 1 Absolute Maximum Ratings** ( $T_a = 25^\circ\text{C}$ )

Item	Symbol	Ratings	Unit
Collector to base voltage	$V_{CBO}$	15	V
Collector to emitter voltage	$V_{CEO}$	8	V
Emitter to base voltage	$V_{EBO}$	1.5	V
Collector current	$I_C$	50	mA
Collector power dissipation	$P_C$	80	mW
Junction temperature	$T_j$	150	$^\circ\text{C}$
Storage temperature	$T_{stg}$	-55 to +150	$^\circ\text{C}$

Note: Marking is "ZD-"

Attention: This device is very sensitive to electro static discharge.

It is recommended to adopt appropriate cautions when handling this transistor.

## 2SC5247

**Table 2 Electrical Characteristics (Ta = 25°C)**

Item	Symbol	min.	typ.	max.	Unit	Test conditions
Collector to base breakdown voltage	$V_{(BR)CBO}$	15	—	—	V	$I_C = 10 \mu A, I_E = 0$
Collector cutoff current	$I_{CBO}$	—	—	1	$\mu A$	$V_{CB} = 12 V, I_E = 0$
	$I_{CEO}$	—	—	1	mA	$V_{CE} = 8 V, R_{BE} = \infty$
Emitter cutoff current	$I_{EBO}$	—	—	10	$\mu A$	$V_{EB} = 1.5 V, I_C = 0$
DC current transfer ratio	$h_{FE}$	50	100	160		$V_{CE} = 4 V, I_C = 20 mA$
Output capacitance	$C_{ob}$	—	0.47	0.75	pF	$V_{CB} = 5 V, I_E = 0, f = 1 MHz$
Gain bandwidth product	$f_T$	10.5	13.5	—	GHz	$V_{CE} = 4 V, I_C = 20 mA$
Power gain	PG	14	17	—	dB	$V_{CE} = 4 V, I_C = 20 mA, f = 900 MHz$
Noise figure	NF	—	1.2	2.5	dB	$V_{CE} = 4 V, I_C = 5 mA, f = 900 MHz$

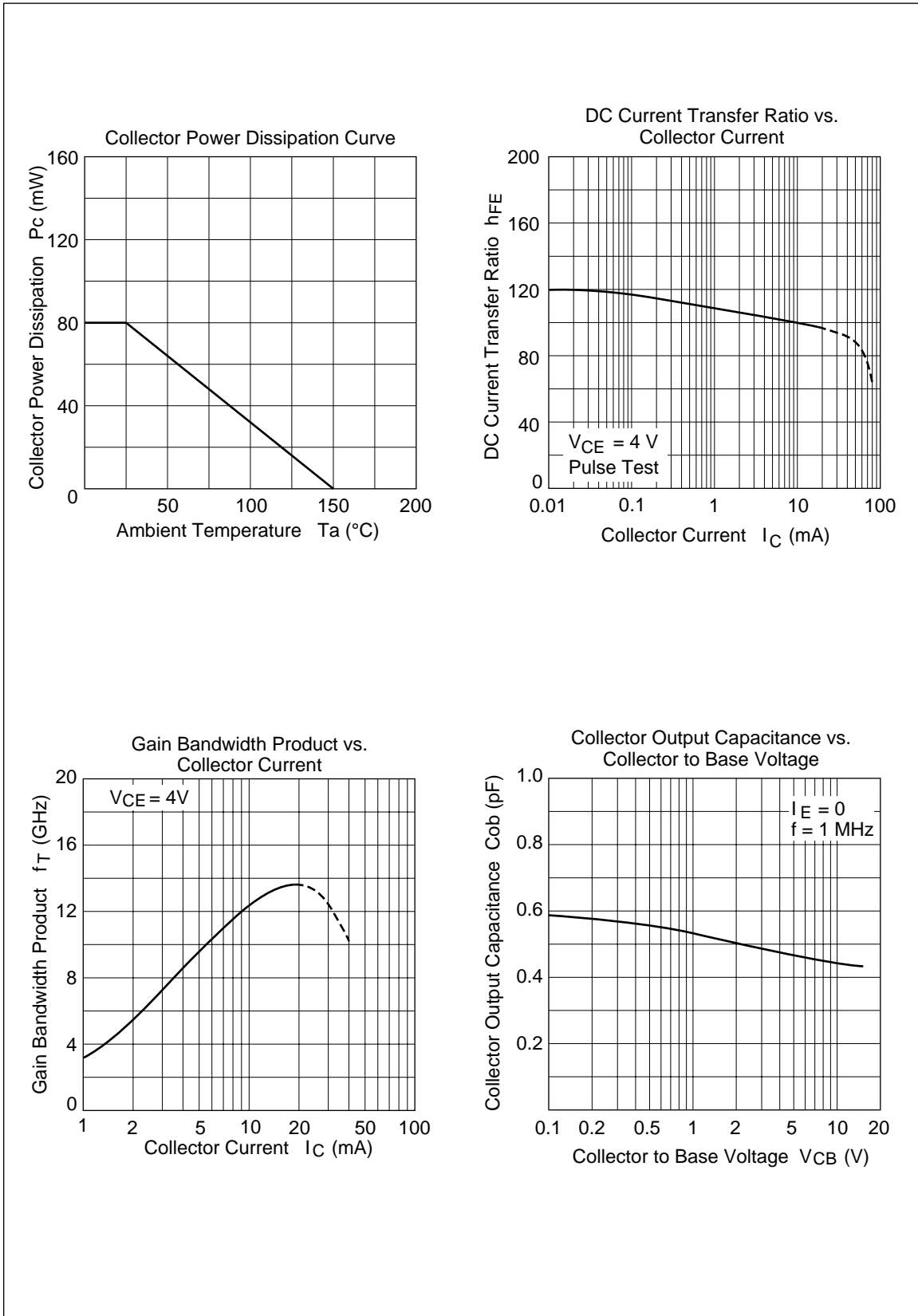

## 2SC5247

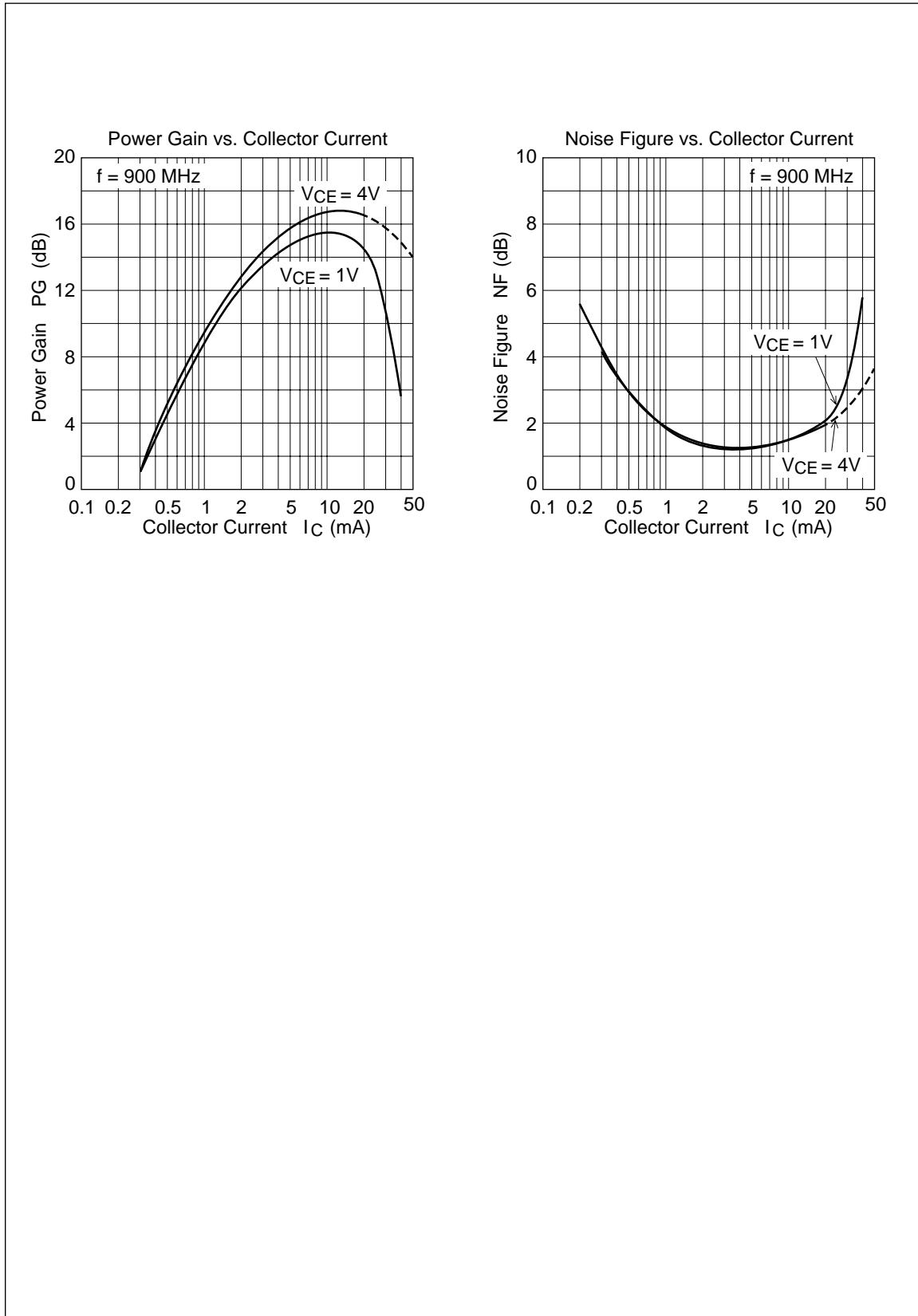

S11 Parameter vs. Frequency

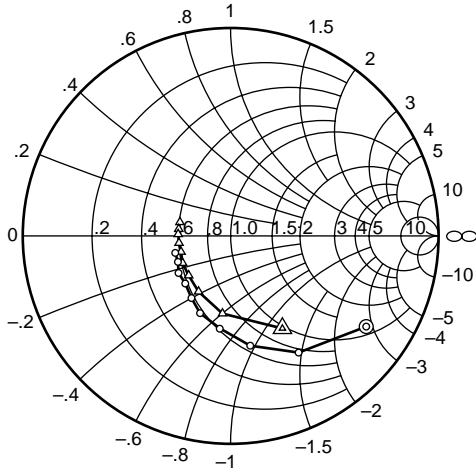

Condition:  $V_{CE} = 4\text{ V}$ ,  $Z_o = 50\ \Omega$   
 200 to 2000 MHz (200 MHz step)  
 ○ — ○ (Ic = 5 mA)  
 △ — △ (Ic = 20 mA)

S21 Parameter vs. Frequency

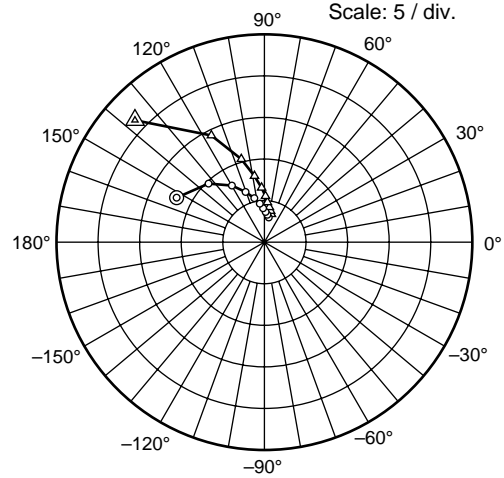

Condition:  $V_{CE} = 4\text{ V}$ ,  $Z_o = 50\ \Omega$   
 200 to 2000 MHz (200 MHz step)  
 ○ — ○ (Ic = 5 mA)  
 △ — △ (Ic = 20 mA)

S12 Parameter vs. Frequency

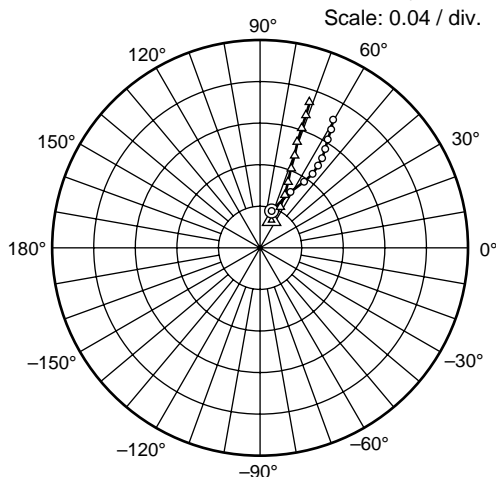

Condition:  $V_{CE} = 4\text{ V}$ ,  $Z_o = 50\ \Omega$   
 200 to 2000 MHz (200 MHz step)  
 ○ — ○ (Ic = 5 mA)  
 △ — △ (Ic = 20 mA)

S22 Parameter vs. Frequency

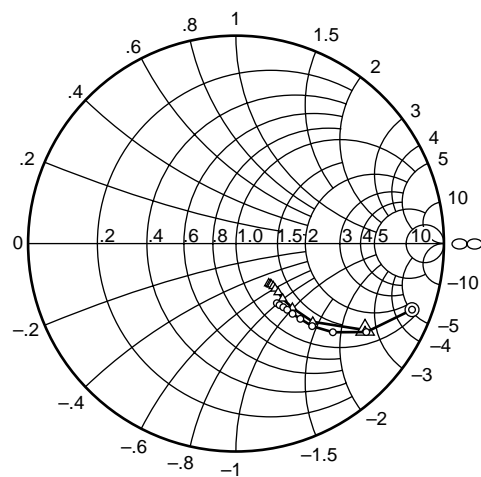

Condition:  $V_{CE} = 4\text{ V}$ ,  $Z_o = 50\ \Omega$   
 200 to 2000 MHz (200 MHz step)  
 ○ — ○ (Ic = 5 mA)  
 △ — △ (Ic = 20 mA)

## 2SC5247

S11 Parameter vs. Frequency

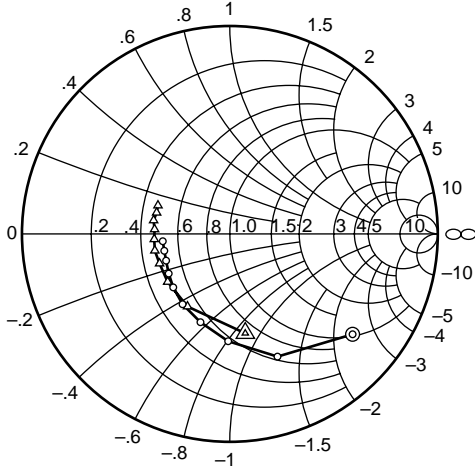

Condition:  $V_{CE} = 1 \text{ V}$ ,  $Z_o = 50 \Omega$   
 200 to 2000 MHz (200 MHz step)  
 ○ — ○ ( $I_C = 5 \text{ mA}$ )  
 △ — △ ( $I_C = 20 \text{ mA}$ )

S21 Parameter vs. Frequency

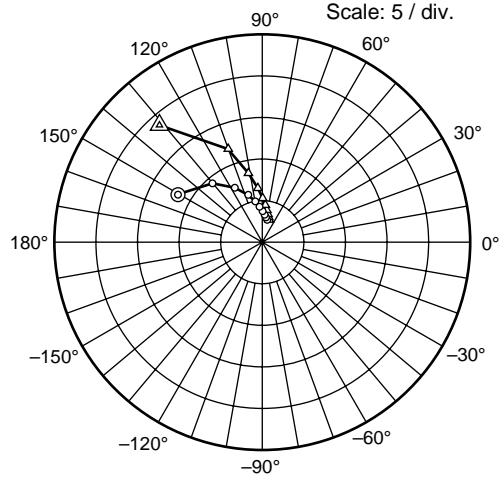

Condition:  $V_{CE} = 1 \text{ V}$ ,  $Z_o = 50 \Omega$   
 200 to 2000 MHz (200 MHz step)  
 ○ — ○ ( $I_C = 5 \text{ mA}$ )  
 △ — △ ( $I_C = 20 \text{ mA}$ )

S12 Parameter vs. Frequency

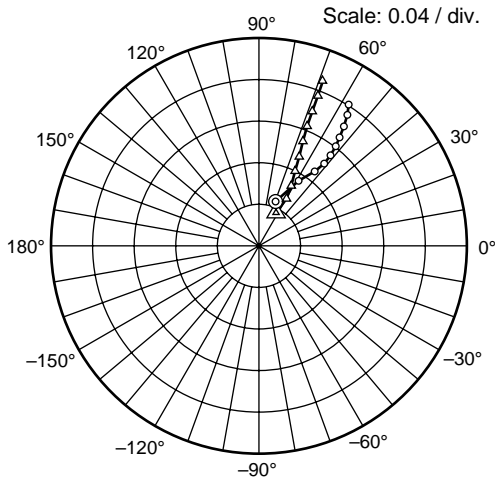

Condition:  $V_{CE} = 1 \text{ V}$ ,  $Z_o = 50 \Omega$   
 200 to 2000 MHz (200 MHz step)  
 ○ — ○ ( $I_C = 5 \text{ mA}$ )  
 △ — △ ( $I_C = 20 \text{ mA}$ )

S11 Parameter vs. Frequency

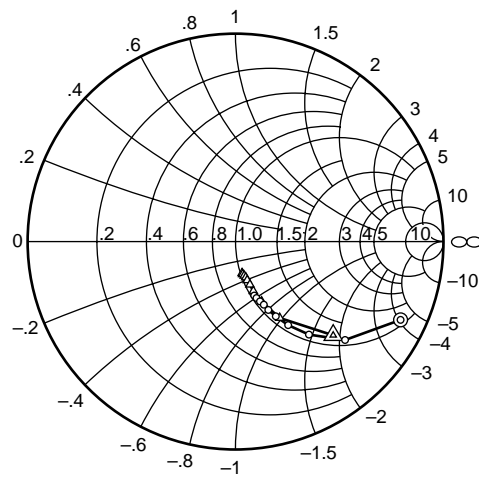

Condition:  $V_{CE} = 1 \text{ V}$ ,  $Z_o = 50 \Omega$   
 200 to 2000 MHz (200 MHz step)  
 ○ — ○ ( $I_C = 5 \text{ mA}$ )  
 △ — △ ( $I_C = 20 \text{ mA}$ )

**Table 3 S Parameter** ( $V_{CE} = 4 \text{ V}$ ,  $I_C = 5 \text{ mA}$ ,  $Z_O = 50 \Omega$ )

f (MHz)	S11		S21		S12		S22	
	MAG	ANG	MAG	ANG	MAG	ANG	MAG	ANG
200	0.785	-33.8	11.8	153	0.037	72.5	0.905	-20.6
400	0.650	-59.8	9.73	134	0.061	61.4	0.758	-34.2
600	0.537	-79.7	7.85	120	0.077	56.3	0.632	-42.5
800	0.450	-96.7	6.54	111	0.087	54.6	0.540	-47.4
1000	0.400	-112	5.43	103	0.097	54.8	0.477	-49.5
1200	0.354	-122	4.67	96.7	0.105	55.3	0.434	-51.2
1400	0.317	-134	4.09	92.1	0.114	56.6	0.403	-52.3
1600	0.308	-145	3.64	87.6	0.123	58.0	0.382	-53.4
1800	0.283	-154	3.32	83.6	0.133	59.0	0.363	-54.7
2000	0.279	-163	3.02	79.8	0.142	60.3	0.348	-55.6

**Table 4 S Parameter** ( $V_{CE} = 4 \text{ V}$ ,  $I_C = 20 \text{ mA}$ ,  $Z_O = 50 \Omega$ )

f (MHz)	S11		S21		S12		S22	
	MAG	ANG	MAG	ANG	MAG	ANG	MAG	ANG
200	0.510	-60.9	21.4	137	0.029	67.3	0.747	-33.8
400	0.376	-96.0	14.3	116	0.044	63.5	0.527	-45.5
600	0.310	-120	10.4	106	0.056	64.8	0.411	-48.7
800	0.278	-137	8.05	98.5	0.069	66.9	0.347	-49.7
1000	0.266	-151	6.56	92.9	0.082	68.5	0.310	-49.1
1200	0.251	-162	5.54	88.6	0.095	69.4	0.287	-49.1
1400	0.252	-172	4.81	85.3	0.108	70.7	0.272	-48.8
1600	0.253	178	4.25	81.8	0.122	70.8	0.261	-49.2
1800	0.252	173	3.83	78.6	0.135	70.9	0.255	-49.8
2000	0.253	165	3.48	75.8	0.148	71.3	0.248	-50.6

## 2SC5247

**Table 5 S Parameter** ( $V_{CE} = 1 \text{ V}$ ,  $I_C = 5 \text{ mA}$ ,  $Z_O = 50 \Omega$ )

f (MHz)	S11		S21		S12		S22	
	MAG	ANG	MAG	ANG	MAG	ANG	MAG	ANG
200	0.763	-39.3	11.6	151	0.046	69.6	0.879	-25.4
400	0.627	-68.8	9.27	130	0.073	58.4	0.708	-42.0
600	0.517	-90.9	7.33	117	0.089	53.2	0.570	-51.8
800	0.448	-108	5.94	107	0.101	51.6	0.475	-57.9
1000	0.408	-124	4.98	99.6	0.111	51.7	0.409	-61.7
1200	0.375	-137	4.28	94.3	0.121	52.4	0.365	-64.5
1400	0.351	-147	3.73	89.2	0.130	53.4	0.333	-66.0
1600	0.333	-157	3.32	84.9	0.141	54.6	0.311	-67.9
1800	0.326	-166	3.02	81.3	0.152	56.0	0.290	-69.8
2000	0.325	-174	2.76	77.3	0.161	57.6	0.275	-71.1

**Table 6 S Parameter** ( $V_{CE} = 1 \text{ V}$ ,  $I_C = 20 \text{ mA}$ ,  $Z_O = 50 \Omega$ )

f (MHz)	S11		S21		S12		S22	
	MAG	ANG	MAG	ANG	MAG	ANG	MAG	ANG
200	0.484	-81.3	18.7	131	0.036	62.6	0.651	-43.8
400	0.404	-120	12.0	111	0.052	59.5	0.425	-60.0
600	0.378	-142	8.49	101	0.066	61.6	0.315	-66.5
800	0.367	-157	6.54	94.6	0.080	64.1	0.254	-70.3
1000	0.370	-168	5.31	89.4	0.094	65.6	0.219	-71.6
1200	0.365	-176	4.50	85.2	0.109	67.1	0.195	-73.3
1400	0.363	177	3.92	81.8	0.124	68.0	0.180	-74.1
1600	0.373	170	3.46	78.3	0.139	68.3	0.170	-75.9
1800	0.367	164	3.13	75.4	0.155	68.5	0.162	-77.6
2000	0.372	158	2.84	72.2	0.170	68.9	0.156	-78.4

### Package Dimensions

Unit : mm

